



The Structural Mechanics of the Mycenaean Tholos Tomb

Author(s): W. G. Cavanagh and R. R. Laxton

Source: *The Annual of the British School at Athens*, Vol. 76 (1981), pp. 109-140

Published by: British School at Athens

Stable URL: <http://www.jstor.org/stable/30103031>

Accessed: 05/03/2010 11:13

Your use of the JSTOR archive indicates your acceptance of JSTOR's Terms and Conditions of Use, available at <http://www.jstor.org/page/info/about/policies/terms.jsp>. JSTOR's Terms and Conditions of Use provides, in part, that unless you have obtained prior permission, you may not download an entire issue of a journal or multiple copies of articles, and you may use content in the JSTOR archive only for your personal, non-commercial use.

Please contact the publisher regarding any further use of this work. Publisher contact information may be obtained at <http://www.jstor.org/action/showPublisher?publisherCode=bsa>.

Each copy of any part of a JSTOR transmission must contain the same copyright notice that appears on the screen or printed page of such transmission.

JSTOR is a not-for-profit service that helps scholars, researchers, and students discover, use, and build upon a wide range of content in a trusted digital archive. We use information technology and tools to increase productivity and facilitate new forms of scholarship. For more information about JSTOR, please contact support@jstor.org.



British School at Athens is collaborating with JSTOR to digitize, preserve and extend access to *The Annual of the British School at Athens*.

<http://www.jstor.org>

THE STRUCTURAL MECHANICS OF THE MYCENAEAN THOLOS TOMB

I. INTRODUCTION

THE method of spanning or roofing spaces by means of corbelling has recommended itself quite widely to primitive peoples. It has been recognized in a number of prehistoric cultures: the megalithic tombs of Copper Age Iberia,¹ tombs such as Maes Howe, Orkney² and Newgrange, Co. Meath,³ in the British Isles, as well as several tombs in Brittany,⁴ employ the method. The Sacred Wells of the Nuragic Culture in Sardinia were also roofed with corbelled domes.⁵ In these west European examples the gap spanned by corbelling tends to be relatively small, two or three metres, and the slope of the corbelling conservative. The point is demonstrated clearly by the 'tholos tombs' of Iberia; the greatest distance of their chambers is covered by a single slab, and their walls are corbelled out only a relatively short distance.⁶ The technique was by no means limited to the illiterate communities of prehistoric Europe. Relatively modern examples have been reported from the south of France⁷ and from Italy,⁸ where the technique is used for roofing buildings which are not covered by the earthen mounds found over the megalithic tombs. The Egyptians of the Old Kingdom used a steep and narrow corbelling to roof the passages and chambers of, for example, the Bent Pyramid of Sneferu, and the Great Pyramid of Kheops at Giza.⁹ However the skill and daring of the Mycenaean engineers who commonly spanned distances of eight metres, and in the largest tombs over fourteen, is unmatched in the history of the technique. Indeed only the invention of the true dome enabled larger spaces to be bridged without internal supports.¹⁰ As the Mycenaean tholos tombs illustrate the technique at its most perfect, they provide an especially appropriate example from which to examine the principles of corbelled structures.

It is not the intention of this study to examine the whole question of the architectural design and construction of tholos tombs. There are many facets of this general question which will be referred to only in passing: the nature of the materials used, the building methods applied, the structural weak points of the design, the aesthetics of proportion, the typology of the tombs, and the history of their development.

These elements have recently been discussed thoroughly and with elegance by Pelon.¹¹ The point of our research is to stress as a major issue the structural stability of the vault, and how it adapts to settlements and other forces. The theoretical approach pioneered by Heyman into the equilibrium of shell and similar structures has proved especially valuable in directing our investigation.

¹ G. and V. Leisner, *Die Megalithgräber der Iberischen Halbinsel* (1943).

² A. S. Henshall, *Chambered Tombs of Scotland* i (1963) 123 ff.

³ C. O'Kelly, *Guide to Newgrange* (1967).

⁴ G. Daniel, *The Prehistoric Chamber Tombs of France* (1960) 80 ff.

⁵ M. Guido, *Sardinia* (1963) 128 ff. and 224 for bibliography.

⁶ G. and V. Leisner, op. cit. pl. 85.

⁷ *Antiquity* 52 (1978) 89 f.

⁸ *Antiquity* 53 (1979) 152.

⁹ C. Aldred, *Egypt to the End of the Old Kingdom* (1965) ill.

75, 79; I. E. S. Edwards, *The Pyramids* (1961).

¹⁰ Larger spans were achieved in timber-roofed buildings during the Hellenistic period: the Arsinoeion, Samothrace, see J. J. Coulton, *Greek Architects at Work* (1977) 158-9, *The Architectural Development of the Greek Stoa* 295-6; rooms M₁ and M₂ in the palace at Vergina, see M. Andronikos *Τὸ Ἀνάκτορον τῆς Βεργίνας* and R. A. Tomlinson in *Ἀρχαία Μακεδονία* i 308-15. We are much indebted to Dr. Coulton for drawing our attention to this point and for supplying the references.

¹¹ O. Pelon, *Tholoi, tumuli et cercles funéraires* (1976).

II. HISTORY OF RESEARCH

In the century and a half of serious study that these monuments have inspired various solutions have been proposed to the question of how the vault was built stable. Curiously one of the earliest descriptions of the Treasury of Atreus has set the pattern for many later accounts. Curious because, although it is the finest tomb to have survived, the Treasury of Atreus is far from typical of the majority of tholos tombs in the type of masonry used in its construction. The section of the tomb (FIG. 1) first published by Donaldson in Cockerell's supplement to the 'Antiquities of Athens' of 1830, is at once the most faithful yet published and the ultimate source of all the sections published until Piet de Jong's of 1923.¹²

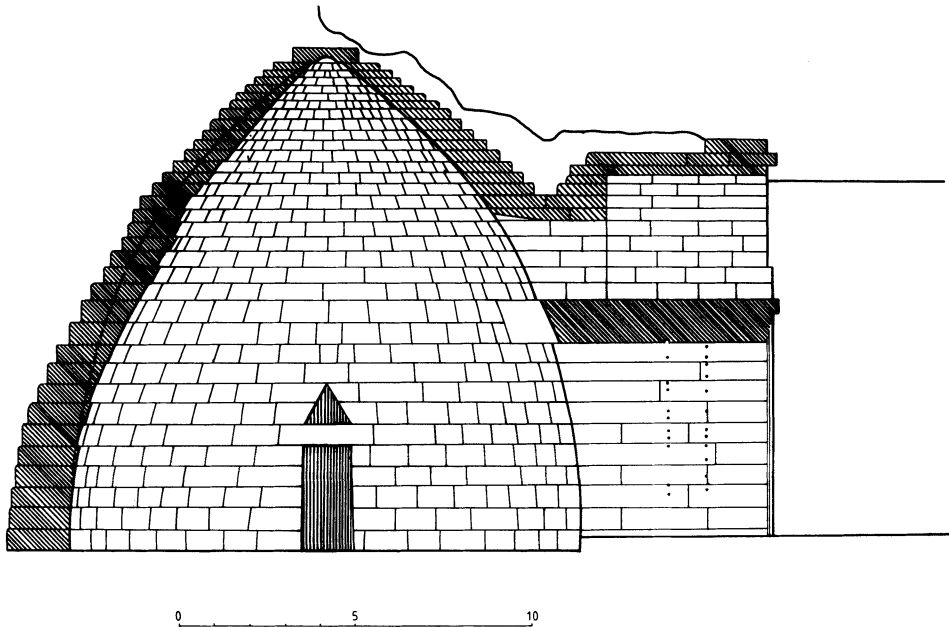

FIG. 1. Section through the Treasury of Atreus (after Donaldson)

Earlier travellers had appreciated that the dome was corbelled, and not built on the principle of the arch;¹³ but Donaldson, relying on an observation made by Cockerell himself, who had cleaned away the earth of the mound to examine the outside of the upper course, remarked that 'in its horizontal position at least, the arch was clearly understood by the architect who designed these chambers, and was depended upon as the essential principle of construction . . . Each stone was found to be worked fair and concentric to a depth of three inches from the inner face of the dome; the remaining part of the joint was less accurate and often rough, but the deficiency was always supplied by small wedge-like stones, driven into the interstices with great force . . .'¹⁴ He illustrates the point with FIG. 2, though it is not clear whether Cockerell had cleared the surface of the whole circle of stones or whether part of the plan has been surmised.

The publication of Lolling's excavation of the tomb at Menidi, some fifty years later, marks the next progress in considering the problem. The tomb at Menidi is a more typical tholos

¹² *BSA* 25 (1923-5) pl. 56.

¹³ e.g. Wm. Gell, 'Argolis'—*The Itinerary of Greece* (1810) 30.

¹⁴ J. Stuart and N. Revett, *Antiquities of Athens* iv (Suppl.) (1830) 30; cf. Leake, *Travels in the Morea* ii (1830) 377 n. a.

tomb, built of rough schist slabs. But although the courses are by no means of the regular dressed masonry found in the Treasury of Atreus, much the same principle as that recognized by Donaldson was held to apply. From his detailed examination of the tomb Bohn saw that although it was not composed of regular courses, the vault was constructed of rings of masonry, and that the gap behind the wall was filled with earth stamped down at regular intervals.

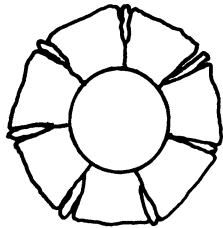

FIG. 2. Plan of the second course of the Treasury of Atreus (after Donaldson)

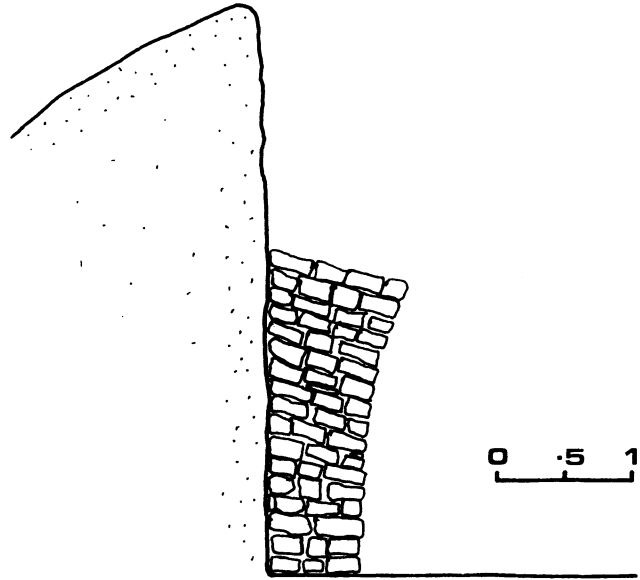

FIG. 3. Schematic section through the wall of tholos tomb A at Kakovatos (after Dörpfeld)

The fill behind the wall by its regular thrust towards the interior would, he believed, lend the building a greater stability. Understandably Bohn comments that his conclusions were limited because he could not examine the structure of the wall's interior.¹⁵ The question of jointing in cyclopean masonry was considered by Adler in his introduction to Schliemann's 'Tiryns', but there is no adequate up-to-date treatment.¹⁶

Dörpfeld, in his article on the tombs of Kakovatos,¹⁷ had to make do with buildings in a sorry state of preservation, but with the advantage that he could examine their structure through the depth of the wall (FIG. 3).

He observed that the filling behind the wall was not simply the packed earth that Bohn and Donaldson had assumed,¹⁸ but consisted of a more carefully built wall, a thickness of several stones. Even the best preserved of the Kakovatos tombs had suffered in its collapse and its wall bulged out of true. All the same Dörpfeld commented on the fact that the layers of stone in the section of the wall were not horizontal but sloped at an angle, which at the height of 1 m can be calculated to $5^{\circ} 42'$, and to $12^{\circ} 48'$ at the height of $2\frac{1}{2}$ m above the floor.¹⁹ He believed that this arrangement was no accident, but that each stone was set in a vertical as well as a horizontal ring; that the structure tended towards a true vault. Dörpfeld also stressed

¹⁵ H. Lolling *et al.*, *Das Kuppelgrab bei Menidi* (1880) 45-7.

¹⁶ H. Schliemann, *Tiryns* (1886) xi.

¹⁷ *AM* 33 (1908) 299 esp. 302-3.

¹⁸ Wace states that the blocks of the Treasury of Atreus are

in fact counterweighted by a heavy mass of rough stones: *BSA* 25 (1921-3) 350.

¹⁹ *AM* 33 (1908) 302 n. 3.

the importance of the clay found in among the stones, which he believed acted as a primitive kind of cement.²⁰

Although much progress has been made in the study of other features of the tombs and their typology since Dörpfeld's account, and although many more have been excavated, relatively little attention has been paid to the question of their statics. In the major publication of the nine tholos tombs at Mycenae, Wace contributed many insights into the use of materials and subtleties of design, but betrayed only a passing interest in the structural stability of the tombs.²¹ His occasional comments indicate that he saw the principles of the cantilever and the horizontal arch as the major factors.

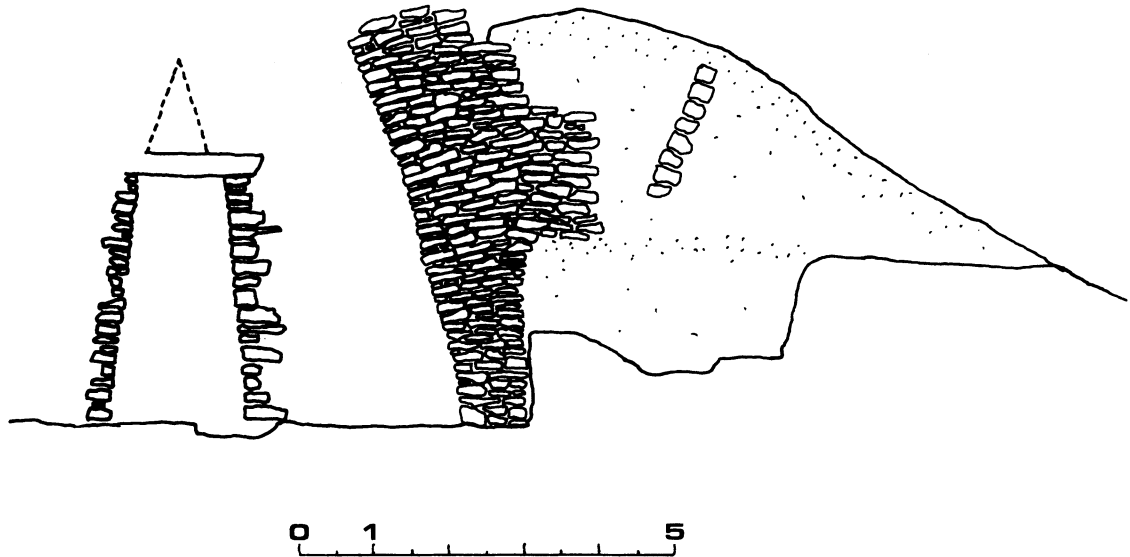

FIG. 4. Cross-section through tomb III, the tholos tomb at Thorikos (after Gassche and Servais)

It is symptomatic that the next important review of the problem resulted from the careful republication of tomb III by the Belgian Mission at Thorikos. Works of restoration enabled Gassche and Servais to examine a cross-section through the tomb in detail (FIG. 4). From their many comments on the structure two are of particular interest to our study. Firstly, they record that the tomb was built in rings of walling, rather than single courses;²² the technique already recognized by Bohn at Menidi. Secondly, they draw attention to the slope of the courses,²³ which with Dörpfeld they see as a deliberate feature approaching in design the true arch. They argue that the slope was intentional, and that the stones on their sloping beds might the better respond to the line of thrust, more or less perpendicular to their slope, than if they were set horizontally.

Pelon has discussed the whole problem in his recent work on tholos tombs, and in conclusion lays stress on corbelling as the basic principle at work.²⁴ His especially clear definition of the operation of corbelling deserves quotation. Each course is cantilevered slightly over the course

²⁰ Even in modern cemented brick walls the value of the mortar is not so much as a bond as in bedding the bricks so that all their joints are even: J. E. Gordon, *Structures* (1978) 175.

²¹ *BSA* 25 (1921-3) 294, 301.

²² H. Mussche, *Thorikos* v 53.

²³ *Op. cit.* 62.

²⁴ Pelon, *op. cit.* 332-6.

below. 'Il vient cependant un moment dans la construction du mur où le centre de gravité se trouve placé à l'extérieur de la surface de sustentation constituée par la base de l'assise de soubassement et où l'ensemble a tendance de basculer vers l'avant. Cet effet d'écroulement doit, de toute nécessité, être compensé par la constitution à l'arrière des blocs en encorbeillement, d'un contrepoids qui déplace le centre de gravité vers l'arrière.'²⁵ The Mycenaean builders avoided using exceptionally long blocks by constructing an interlocking wall to achieve the counterweight.

III. THREE FACTORS CONTRIBUTING TO THE STABILITY OF THE VAULT

Thus far, then, three main factors have been held to account for the stability of these buildings: firstly the use of sloping courses recognized by Dörpfeld and Gassche and Servais, secondly the principle of the horizontal ring, first put forward by Cockerell and Donaldson, and thirdly the technique of corbelling, as clearly expounded by Pelon. Let us consider these factors in turn. Dörpfeld argued that the use of sloping courses was deliberate and that in its vertical construction the tholos approached a true arch.²⁶ In the case of the tholos tomb, however, there is no keystone to complete the arch; on the contrary the ogival or bottle-shaped profiles of the tomb at Tiryns, and the Tomb of the Genii at Mycenae, indicate an almost wilful determination to avoid anything like an arch. Gassche and Servais have also maintained that the slope in the courses was an intentional feature of construction, for the reason that sloping courses respond better to the line of thrust. But whether its courses are horizontal or sloped the resolution of the forces in the vault will be normal, or at right angles, to their bedding. It appears to us that the slope of the courses at Kakovatos and Thorikos need not be deliberate; it may be due in part to a tendency to place the thicker, heavier end of a rough-schist block towards the interior of the stonework, in part to the tendency of the courses to tip under a bending moment, in part to settlement after construction and possibly also due to the process of collapse. The problem of the effect of sloping courses, whether originally planned or due to later settlement, on the stability of the tombs is investigated further below. We will start from the assumption that the courses were laid horizontally, but our analysis goes on to consider the effect of sloping courses.

The second principle, that of the horizontal arch coined by Donaldson, is not so simple in its application as might at first seem. Donaldson believed that the horizontal arch, or more properly ring, was 'the essential principle of construction . . .' and that 'By a succession of these cylindrical rings in gradual diminution the artist calculated on their resistance to the superincumbent weight of earth purposely heaped on all sides, and relied on their well secured concentricity for the durability of the interior form of his bold and novel invention'.²⁷ These expressions are not entirely clear. The wedge shape of the voussoirs of the horizontal ring can act by responding to any force along the line of the course such as to cause that course to slide inwards over its bed. In this way, as Donaldson suggests, a limit will be imposed on the degree of distortion to which each ring will be subject. The observation which first led to the formulation of the idea was Cockerell's sketch of the second course in the Treasury of Atreus (FIG. 2). This, the finest of the tholos tombs, is the culmination of a development in which ever greater care was taken to make the courses regular and the joints smooth. Most tholos tombs, on the other hand, are built of rough slabs which were not laid in regular courses and whose jointing is extremely irregular. If the horizontal ring be invoked for the more normal tholos tomb, built of cyclopean or irregular schist walls, it must result not from the careful

²⁵ Op. cit.

²⁶ *AM* 33 (1908) 303 'Bei unserem Kuppelgewölbe ist dagegen jeder Stein in *verticaler* und zugleich auch in hori-

zontaler Richtung in einem Ring eingespannt' (our emphasis).

²⁷ Stuart and Revett, op. cit. 30.

drafting of blocks laid horizontally in the manner of voussoirs: rather the stones would need to jar together, when the structure became compacted, so as to form a tight ring. There is no question in the more common type of tholos tomb that wedges were driven in to secure the arch in the manner suggested by Donaldson. It may be that the Mycenaean masons devised various techniques to ensure that the walls would tighten into a ring. Perhaps they took care that the slabs used were wedge-shaped and placed, like a voussoir, with the thick end inwards.²⁸ Perhaps they placed vertical slabs between blocks to enable the vertical joints to jar more firmly. From observation of the masonry of collapsed tombs we have been unable to confirm either of these suggestions. The excavation or cleaning of the upper course of a collapsed tomb would throw further light on the matter.

An objection to the theory that the horizontal ring in itself resists a major thrust lies in the fact that for two-thirds of the tomb's height the ring is not closed. The gaps of the stomion and relieving triangle intervene. In this lower part of the tombs, where the ring is cut, the lateral pressure must be less than the forces of friction which prevent the stones of the jambs of the stomion and the sides of the relieving triangle from being dislodged. In the upper third, where the vault's wall is most concave, the horizontal ring may contribute towards the stability of the structure. In addition to responding to any forces along the line of the courses, the horizontal ring would improve the dome's stability by distributing evenly round the structure the forces from all directions. Certainly there can be no doubt that a horizontal thrust has caused some distortion in the shape of the tombs. Its effect is demonstrated by the irregularities of the slope of the vault, apparent in the sections of all the tombs. Donald-

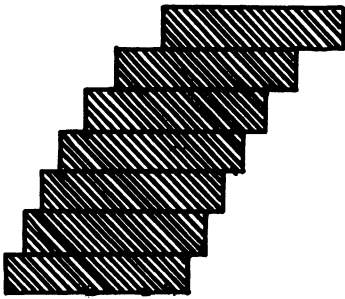

FIG. 5. Simple corbelling

son commented on this very shift, which he illustrated on his section of the Treasury of Atreus by a dotted line (FIG. 1). If we grant that the surface of the Treasury of Atreus was smoothed after construction was finished, then the distortion must have followed some time after the tomb was completed. In other words neither the horizontal ring nor friction can have been brought rigidly to bear during construction. No doubt the removal of scaffolding, if indeed it was used, settlement of the mound, the action of rain, frost, and earth-tremors, will have caused the tombs to settle after a period, and change their shape and equilibrium.

It remains to mention the operation of the third principle: the system of corbelling. For us this is the major factor and the basis of our structural analysis. We should define corbelling as the method of spanning spaces by jutting out successive courses one over the other in such a manner that the total mass of the superincumbent masonry acts at each course within the main body of the structure (FIG. 5). Here the courses have equal length, l say. It can be shown that if the first course (starting from the top) projects beyond the second by $\frac{1}{2}l$, the second beyond the third by $\frac{1}{3}l$, and so on, then the structure will not fall over. The total distance spanned by the first n courses is therefore $\frac{1}{2}l + \frac{1}{3}l + \frac{1}{4}l + \dots + l/(n+1)$ and it can be demonstrated that any distance can be spanned, no matter how large, by taking a large enough number of such courses. However, it is not a necessary feature of (general) corbelling that the courses are of equal length. Indeed, the specific form the corbelling takes in a tholos tomb is discussed in detail below. Suffice it to say here that if the course length is allowed to increase from the

²⁸ The bottom course of the tomb at Vagenas, Englianos, is laid according to the opposite principle, that which applies more generally in drystone walls, whereby the narrow, pointed

end is placed away from the surface: C. W. Blegen, *Palace of Nestor* iii (1973) fig. 327.

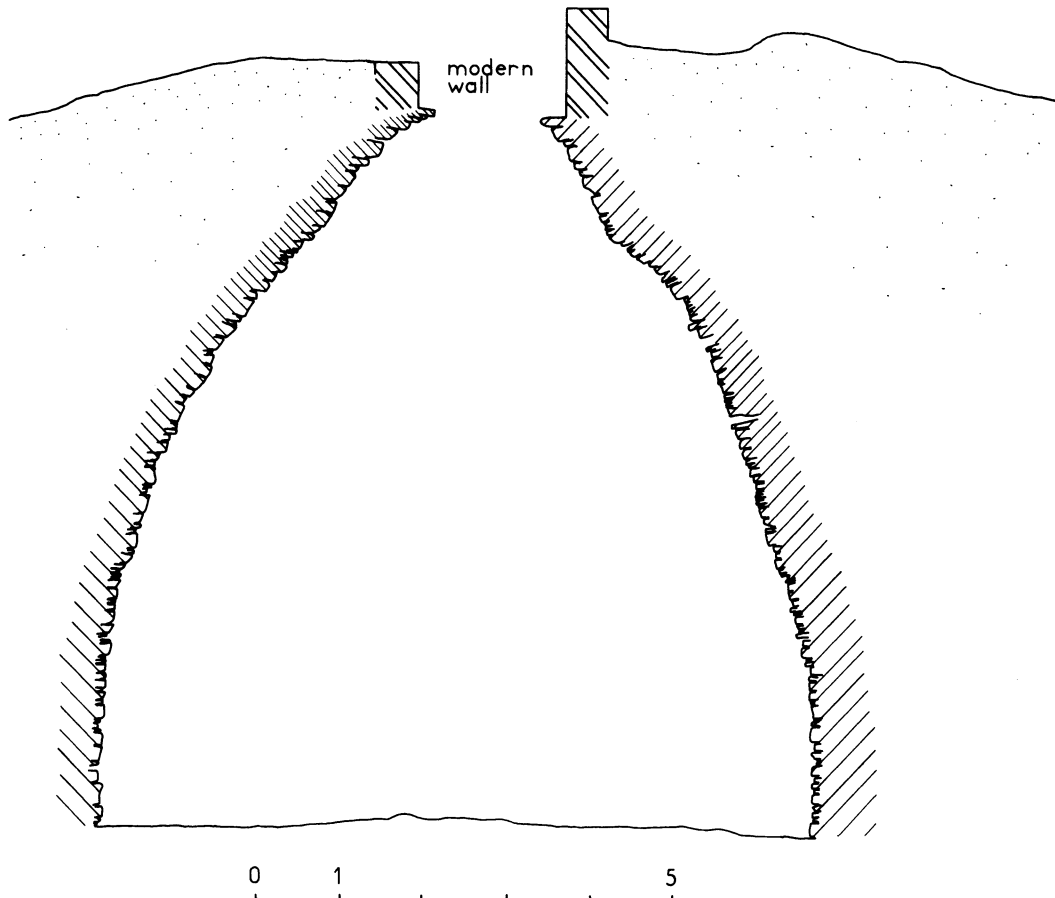

FIG. 6. Section through the tholos tomb A at Dimini

top down, then a greater distance can be spanned by fewer courses of equal thickness and a similar result holds if the whole structure is covered by earth.

IV. STRUCTURE OF THE VAULT

Such is the current state of research. It is our intention to examine the forces at play by using two complementary techniques: carefully measured plans and mathematical analysis. In the first case a number of tholos tombs standing complete to the capstone, or nearly so, have been carefully surveyed, and their internal sections drawn at scales varying from 1 : 20 to 1 : 30 (FIGS. 6 to 9).²⁹

For the Treasury of Atreus, which we had not the resources to measure, we rely on the section published by Donaldson (FIG. 1). The tombs chosen cover a wide range geographically, chronologically, and in building styles. In the calculations we have used measurements taken

²⁹ The survey used direct measurement by tapes. Two guide tapes were placed equidistant and at the same level either side of the diameter, so as to ensure that a true vertical section was measured. A third tape, whose height and position in relation to the others was known, enabled each point on the

section to be calculated. In the cases of the Tomb of the Genii, Marathon, and Karditsa the measurements were cross-checked by plumb line and found to be correct and accurate within the limitations of the scale. W.G.C. owes much useful advice to Dr. J. Coulton, who discussed the problem with him.

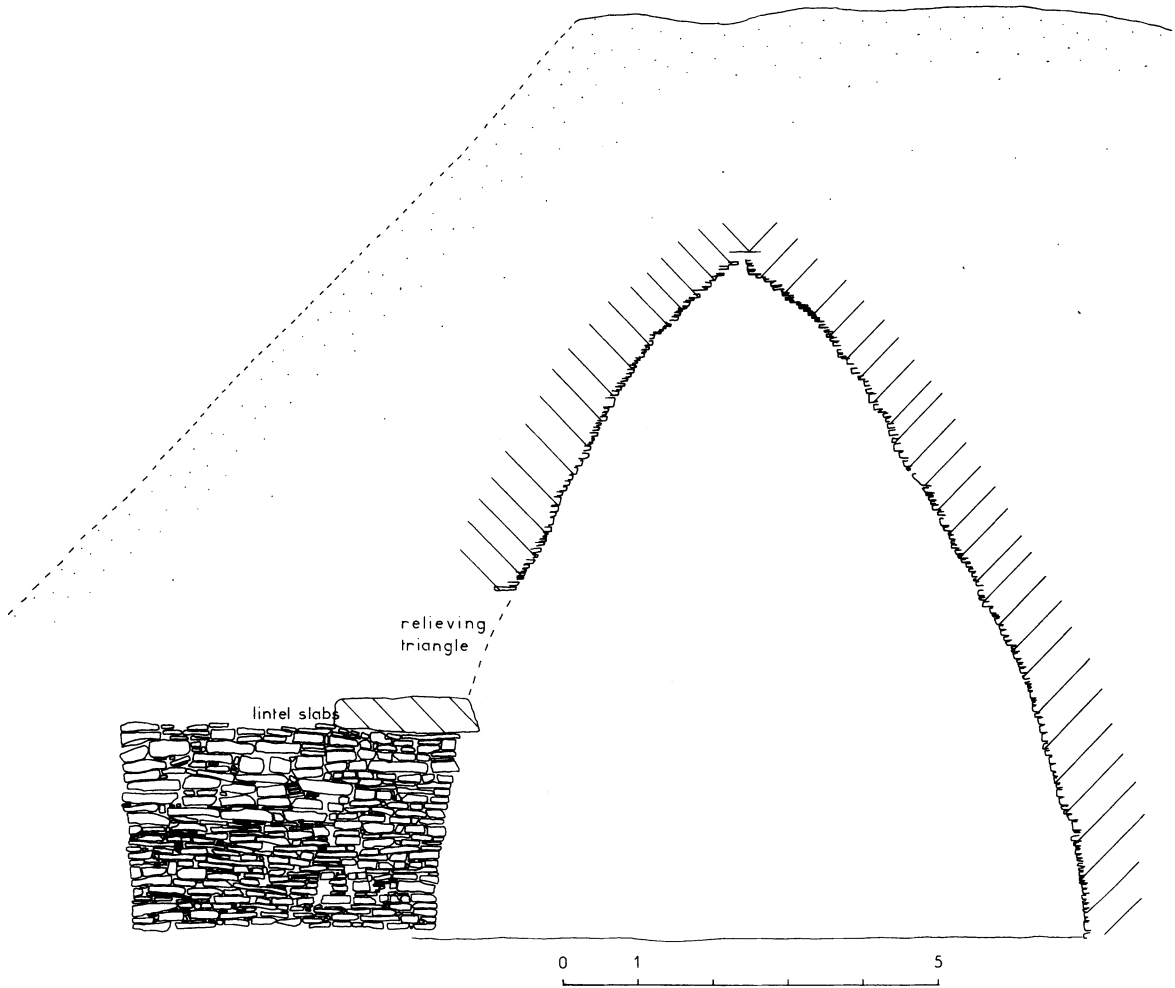

FIG. 7. Section through the tholos tomb at Karditsa

from the drawn sections. The accurate record of the curvature of the vault in these tombs provides both a known for the mathematical analysis and a test of the solution. We are still faced with a number of uncertainties. Whilst on the one hand the complete tholos tombs enable us to record the slope of the dome at each course, on the other they suffer from the disadvantage, from the point of view of our analysis, that the composition of the wall and of the mound behind the wall, is unknown. The only way to obtain certain information on these details of the structure is by excavation of a partly collapsed tomb which has not otherwise been too much disturbed. Certain assumptions are, therefore, made as to the construction of the vault. We believe that these assumptions are in themselves reasonable, and they are supported by the evidence of tholos tombs which have collapsed and thereby revealed similar structural details.

The lowest section of the vault was built within a cylinder excavated out of the bedrock; the thickness of the lower part of the masonry is thus limited by the radius of the cylinder (FIG. 3). There is evidence to suggest that the thickness of the stonework at its base stood to

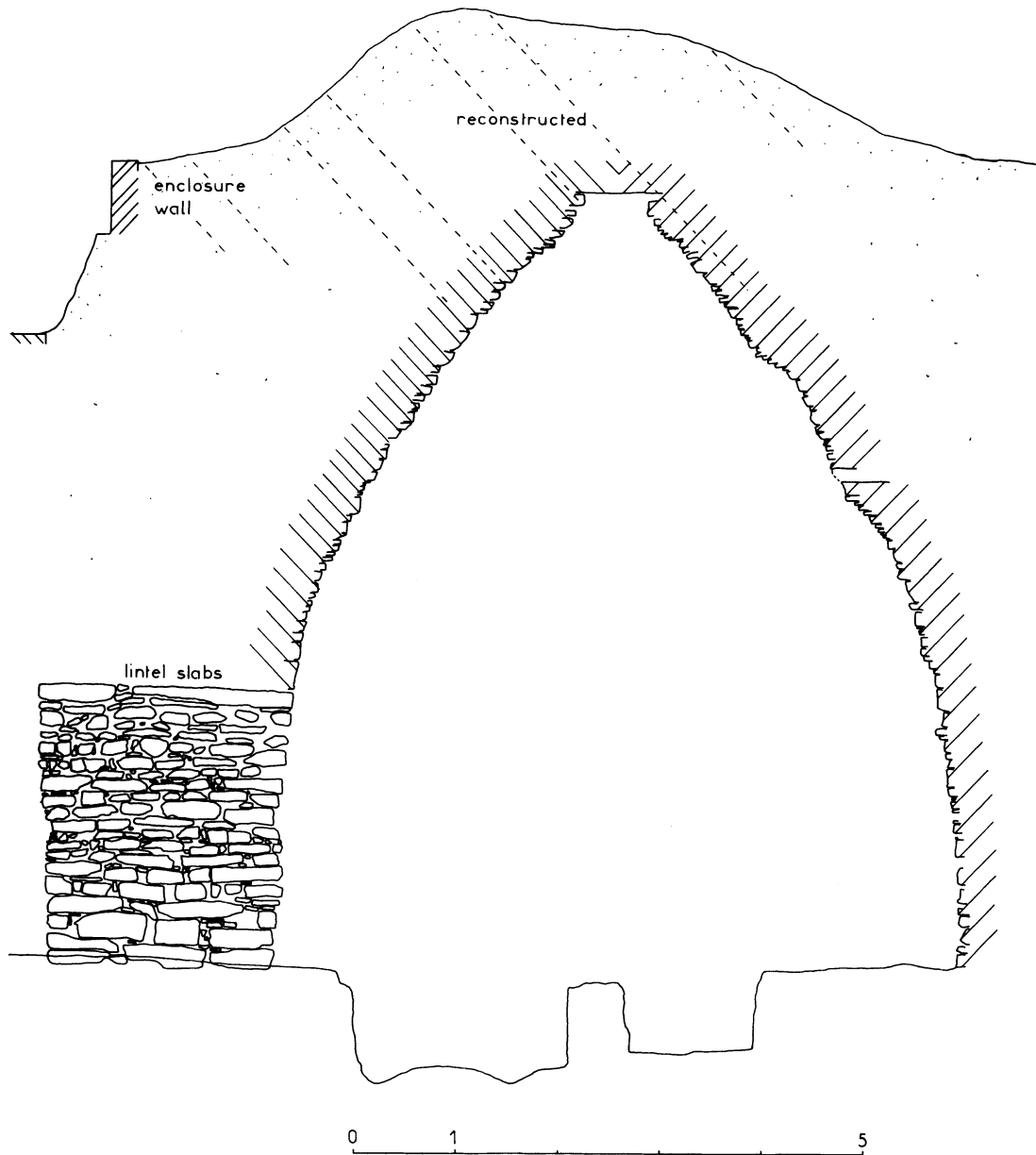

FIG. 8. Section through the tholos tomb at Marathon

the radius of the tomb at a ratio of very approximately 1 : 6.³⁰ Our first assumption is that some such formula applies in the case of the complete tombs. This assumption does not much affect the calculations for the more critical upper part of the chamber, what we term the *dome*. Once the vault reached a height above the rim of the cylinder of bedrock its thickness was no longer so limited. Evidence can be cited from two observations to support our second assumption that the masonry was built thicker at the top of the cylinder than within the

³⁰ Pelon, *op. cit.* 346f. gives a more circumstantial account; the ratio varies greatly from tomb to tomb.

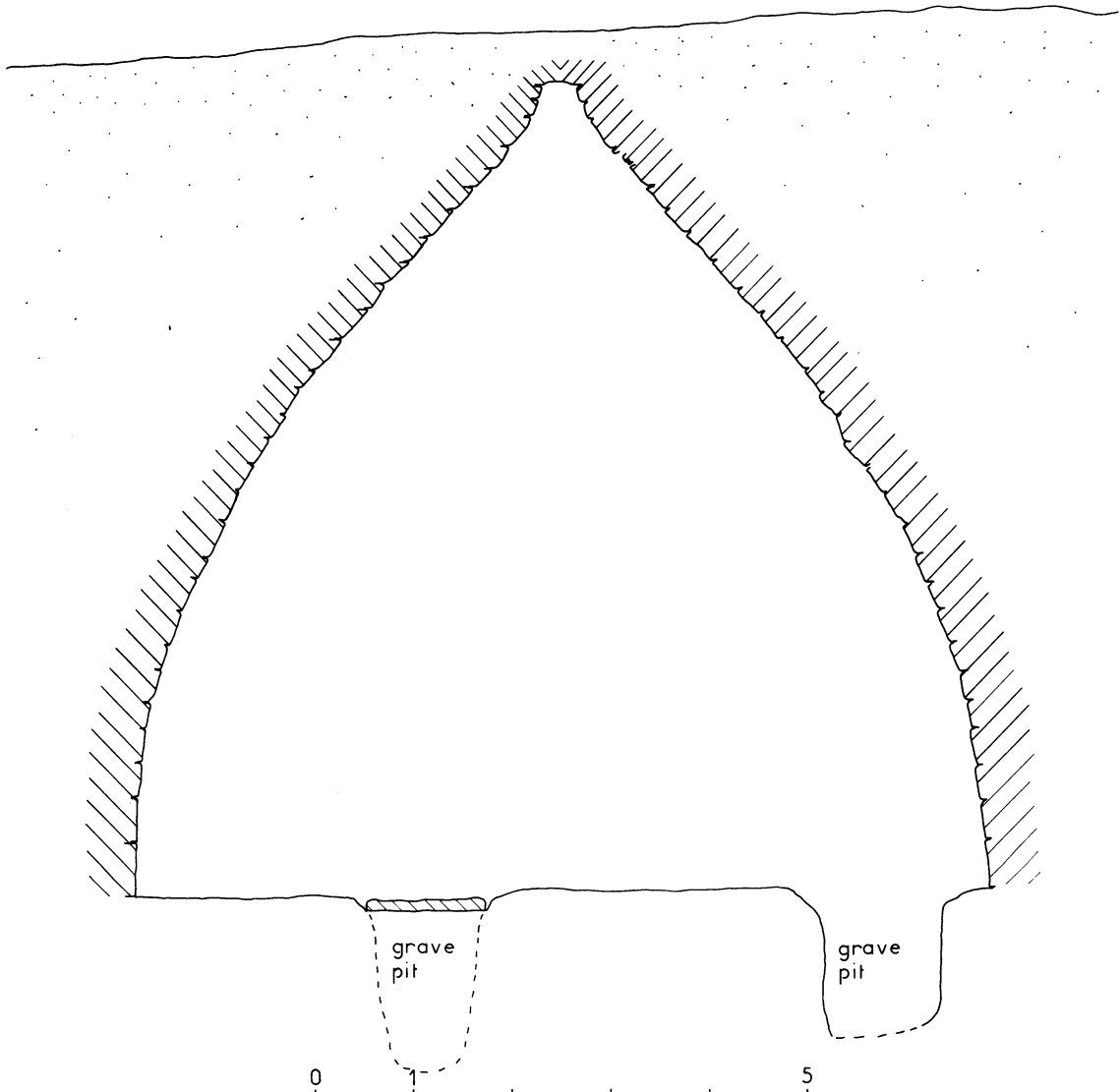

FIG. 9. Section through the Tomb of the Genii, at Mycenae

cylinder itself. Firstly, in the circular tomb at Thorikos precisely such a thickening has been observed (FIG. 4). Secondly, the curvature of the vault always becomes less concave in the lower half of a tholos tomb. One reason for this relatively conservative slope is that it lends the structure greater stability precisely at its weakest point, at the entrance. A further reason is that the greater incline in the upper part of the vault or the dome requires a greater thickness of stone to counterbalance the moments at this point than would be possible were its thickness limited by the cylinder of bedrock. There is presumably an economy of labour if the steeper upper section of the vault is sprung from the top of the bedrock: only earth need be shifted, there is no need to quarry away rock. Our third main assumption is that having reached its thickest at the rim of the bedrock the masonry becomes regularly thinner as it nears the

cap-stone, to give a crescent-like section. Again this assumption is supported by the findings at Thorikos (FIG. 4). On these assumptions we have drawn the section of an ideal tholos tomb (FIG. 10); our structural analysis is based on this form for a dome.

V. SIMPLE PLASTIC THEORY AND MASONRY BUILDINGS

The application of plastic theory to masonry structures has been studied extensively by Heyman in a series of articles³¹ and most recently in a monograph.³² Plastic theory was originally developed for steel frames, but Heyman has observed that it is equally valid for masonry structures under the following conditions:

(i) *Stone has no tensile strength.* This is a reasonable and safe assumption for us to make since we are dealing with buildings constructed in dry masonry, or at most with a weak mortar. Thus no tensile forces can be transmitted within the bulk of the structure.

(ii) *Stone has an infinite compressible strength.* Here we assert that the stone will not be crushed by the forces within the building. This supposition seems reasonable and will not lead to serious error in the analysis.

(iii) *Sliding cannot occur.* It is assumed that there is friction between the blocks of stone and that these are effectively locked together in various ways, so that they cannot slide one over another.³³ In all probability this supposition is the most vulnerable in the problem at hand. Consequently, later on in the analysis, when the case of sloping courses is considered, we will make some calculations to see if and when friction alone can stop the outward sliding of one course over another. Initially, however, this assumption can be safely made, since the analysis will start with the case of a tomb built in horizontal courses where all the forces are vertical.

(iv) *The mass of the structure remains substantially the same.* In the special case of the tholos tombs an earthen mound is an essential feature of the structure; erosion of the mound might in some cases have led to the collapse of the tombs.

In the analysis we will ensure that at all points the line of thrust is in equilibrium with the forces acting on the tomb, initially just the self-weight including that of the earthen mound, and lies entirely within the masonry structure. The *safe theorem*³⁴ of plastic theory states that if these two conditions are satisfied, then the structure is stable. Needless to say this stability refers only to small deflections such as are brought about by small settlements; it does not and cannot take account of large ones, which would significantly alter the geometry of the building. What the safe theorem does assert is that if the building is stable before a small deflection, then it will remain stable afterwards even though the line of thrust may have changed significantly as a result. The point is that if the line of thrust lies within the masonry before such a movement then it remains within afterwards. This tenet applies even if the line of thrust runs along the masonry's surface, that is the interior surface of the tomb; for tensile forces would be required to move the line of thrust out. What happens in the case of minor deflections is that the dome's shape will undergo small changes and thereby keep the line of thrust within the stonework. In terms of the tholos tombs this means that the stone courses would change their angle of inclination with respect to the horizontal.

The *safe theorem* carries with it an important implication. It allows that the line of thrust considered need not be the actual line; so long as there exists one line at equilibrium within

³¹ J. Heyman: for example, 'The Stone Skeleton', *Inst. J. Solids Structures* 2 (1966) 249, 'The Safety of Masonry Arches', *Int. J. mech. Sci.* ii (1969) 363 and 'The Strengthening of the West Tower of Ely Cathedral', *Proc. Instn. Civ. Engrs.*, pt. 1 60

(1976) 123.

³² J. Heyman, *Equilibrium of Shell Structures* (1977).

³³ See our discussion above.

³⁴ J. Heyman (1969) 635.

the masonry this ensures that the building will not collapse. The discovery of the actual line in a particular standing tomb will, in general, be impossible because of the large number of unknowns, such as the settlements and resulting deflections. In practice the theorem means that if a tomb is completed by the builders and remains up for a generation, then that is a fair guarantee that, acts of God and man excepted, it will stand up to the present day!³⁵

VI. SIMPLIFICATIONS FOR THE PURPOSES OF ANALYSIS

(i) The funnel and capstone at the top of the tomb are ignored, as are the door and the opening of the relieving triangle (FIG. 10). The lower part of the tomb is assumed to lie within a rock cylinder carved out of the bedrock. Only that part of the tomb which we refer to as the dome, that is to say the upper part of the chamber where the slope of the vault is most concave, is considered. We have taken the dome to be that part of the vault which extends from the top down to the lintel above the door of the tomb; exact locations of these are indicated in the tables of measurements (TABLES 4 to 7).

(ii) The stone courses are assumed to be horizontal. Each course is taken to have a vertical thickness Δ cm which is small compared to the overall size of the tomb. In the tombs studied here Δ varies from about 3 cm in some to about 25 cm in others, and heights of the tomb from about 8 m to 13.5 m. It is convenient to term any stone course together with the earth of thickness Δ projecting immediately behind it, a *level* (FIG. 10). At a later stage we shall consider the situation where the courses are moved from the horizontal by subsidence or some other effect.

(iii) The surface of the earthen mound covering the tomb is taken to be horizontal. Some ground surfaces slope on some sides but on the whole this supposition is not a serious distortion. The earth above the top of the capstone is taken to be of thickness Δ also. This level is then called the 0th level; the k th courses are numbered consecutively 0, 1, 2, ... from the top of the vault (FIG. 10). the k th course is then at a depth Δk from the top of the capstone. In practise the thickness of the earth level above the top of the tomb varies both around the circle and from tomb to tomb. We shall show in the course of the analysis below, that within reason this variation is not too important (see Appendix).

(iv) The stone and earth are assumed to have uniform densities. As the analysis progresses these densities will be taken to be identical.³⁶

(v) As the lines of the courses descend from the top down to the n th course (a depth of Δn) and the radius $F(\Delta n)$ of the tomb's inner surface increases, we assume that the horizontal depth $l(\Delta n)$ of the stone in the n th course gets proportionally greater (FIG. 10). Expressed in symbols this means that $l(\Delta n) = \beta F(\Delta n)$ where β is a positive constant (i.e. the same for all n). The closing remarks of section IV considered the archaeological background to this point. The elevation of the tomb at Thorikos (FIG. 4) suggests that a value for β of $\frac{1}{2}$ to 1 is not unreasonable.

(vi) The following is a more technical assumption. In our analysis we begin by cutting the dome vertically into elemental wedges (FIG. 10). In such a wedge we consider the total weight of earth and stone acting down on the n th course. Its line of action has, for stability, to lie within the stone course; that is at a certain distance from its inner edge. We write this distance as a product $\delta(\Delta n)l(\Delta n)$. (In the appendix we deduce as a result of our assumptions that $\delta(\Delta n) = \delta$ is a constant independent of n). It is to be noted that in an analysis which took no account of plastic theory, we should normally demand that the line of action of the total

³⁵ J. Heyman, op. cit.

³⁶ Experiments carried out by W.G.C. suggest that this is reasonable.

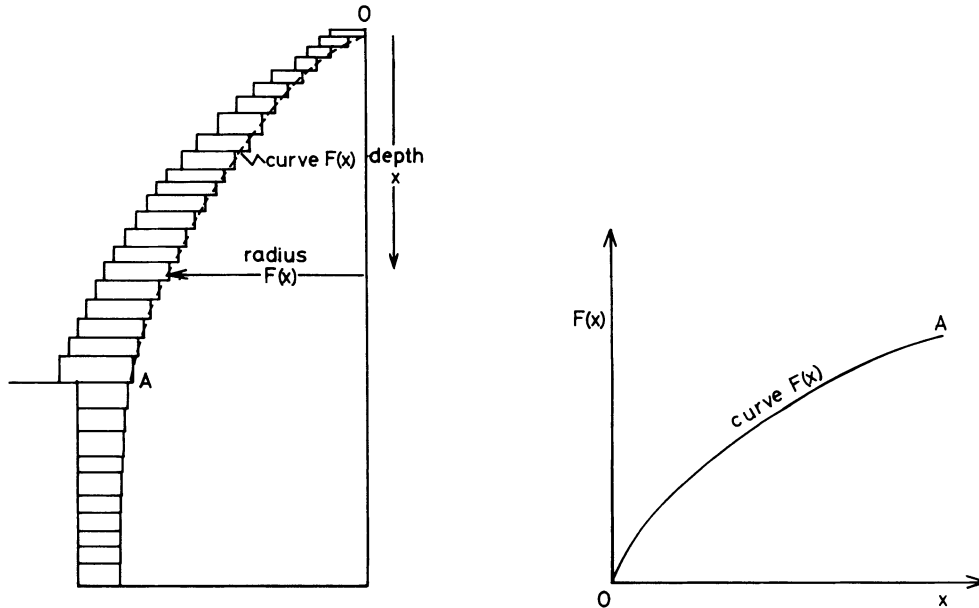

FIG. 11. The line of the inner surface of the vault and the same in graphical form

β is unknown but of the order $\frac{1}{2}$ to 1, say. We shall deduce from an analysis of the structural mechanics of the tombs a class of equations which describes the shapes of the inside surfaces of the tombs. It will be seen that the curve derived is in very good agreement with those of five tombs measured. It is to be noted that the line of thrust is decided solely with reference to the self-weight of the structure; there is no appeal to the ring principle, and for that reason the gaps of relieving triangle and stomion present no difficulty. The least value of β for which this class of equation is possible can be determined by taking $\delta = 0$, i.e., when the line of force runs down the inner surface of the tomb.

We demonstrate that there is a perfectly simple method of construction to effect the shape deduced.

After this initial analysis we turn to consider what happens if the courses are no longer horizontal. Such tilting could occur, for example, after construction if settlement took place below the bottom course of the dome, or at the springing of the dome (FIG. 10). In this case the dome acts in a fully three-dimensional manner, and we have to check that the forces which come into play are not so strong as to cause slipping of one course over another.³⁸

Detailed calculations are recorded in the appendices; only the final result and graphical analyses are shown in the main body of the text.

VII. THE SHAPE OF THE INNER SURFACE OF A THOLOS TOMB

It is convenient in the final stages of the analysis to replace the discontinuous measurement Δn of the depth of the n th course below the top by a continuous measurement x . At the same time $F(\Delta n)$ is replaced by $F(x)$. This is illustrated in FIG. 11 both as in the tomb itself and in a graphical form.

The curves in graphical form of the inner surfaces of the domes of the five tholos tombs,

³⁸ We are grateful to Professor Heyman for pointing out this aspect of the problem to us.

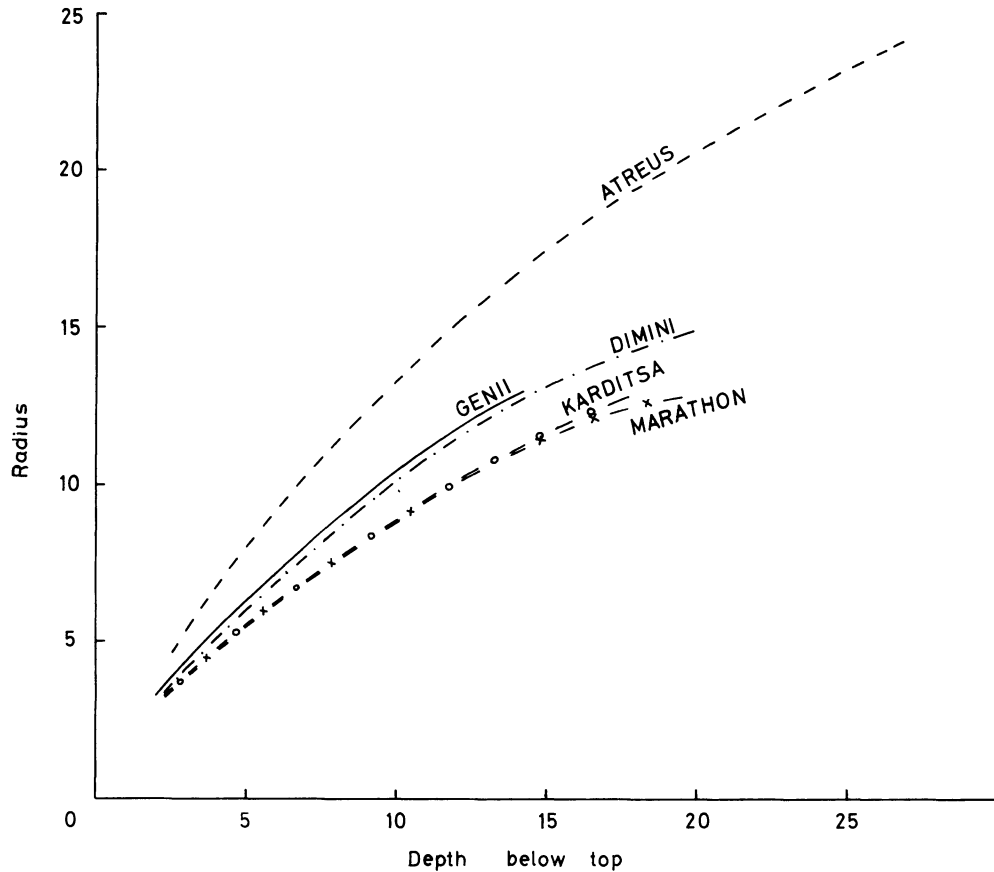

FIG. 12. Plots of the curves of the inner surfaces of the domes of the five tombs (the measurements are taken from tables 4-8)

i.e. the Treasury of Atreus, the Tomb of the Genii at Mycenae, tomb A at Dimini, and the tombs at Marathon and Karditsa are plotted together in FIG. 12.

That for the Treasury of Atreus is of the east side while the remaining four are averages of opposite sides.

It is predicted in the Appendix that, provided certain conditions are fulfilled all the equations will have the form:

$$F(x) = cx^d$$

where the constants c and d are to be determined for each tomb. Such an equation can be made into a linear equation by taking logarithms on each side to obtain:

$$\log F = d \log x + \log c.$$

Thus we predict that if the curves of the internal surfaces of the domes (i.e. down to the lintels) of the tholoi in Fig. 12 are replotted on log-log graph paper, then they will become five straight lines. These plots are shown on FIGS. 13 to 17, and it can be seen that they are all straight lines to a very acceptable level of accuracy. (The straight lines are best least-squares estimates. In all cases the correlation coefficients are greater than 0.994. In some a 'tailing-off' by points from the straight lines can be seen. These points correspond to courses at the bottom

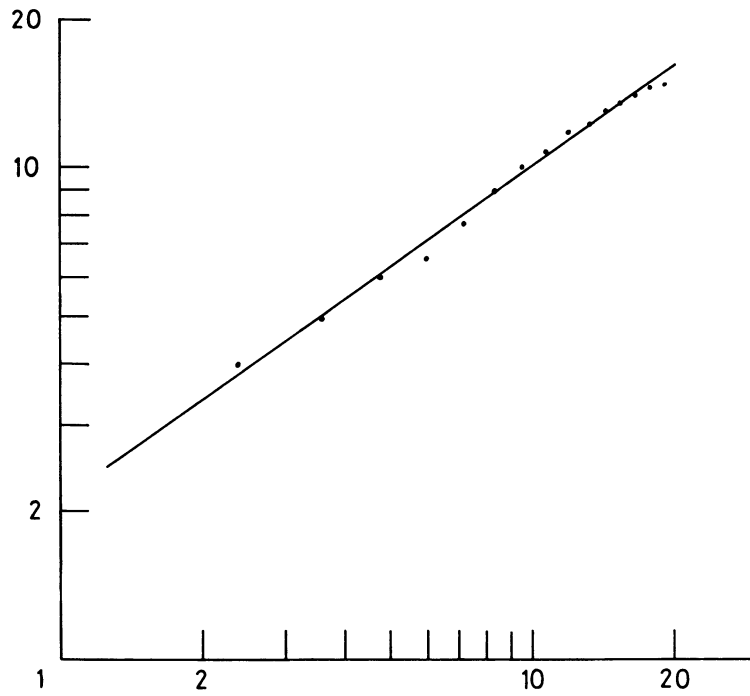

FIG. 13. Plot on log-log scales of the curve of the inner surface of the tholos tomb at Dimini (average)

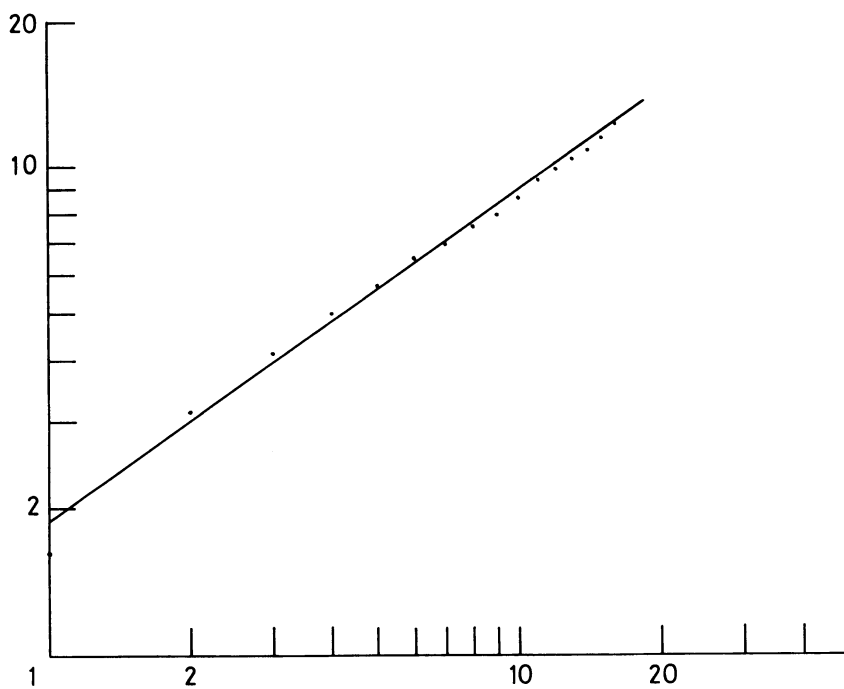

FIG. 14. Plot on log-log scales of the curve of the inner surface of the tholos tomb at Karditsa (average)

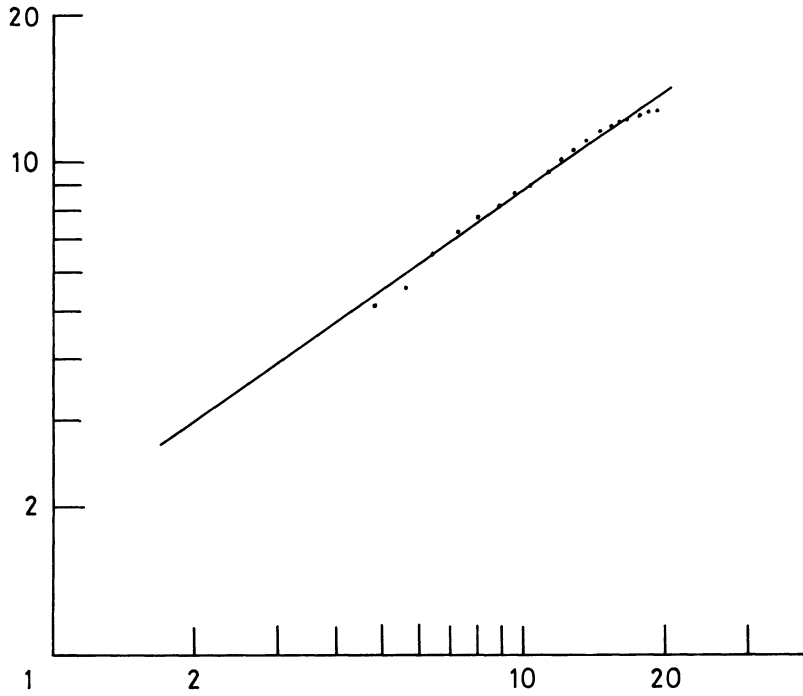

FIG. 15. Plot on log-log scales of the curve of the inner surface of the tholos tomb at Marathon (average)

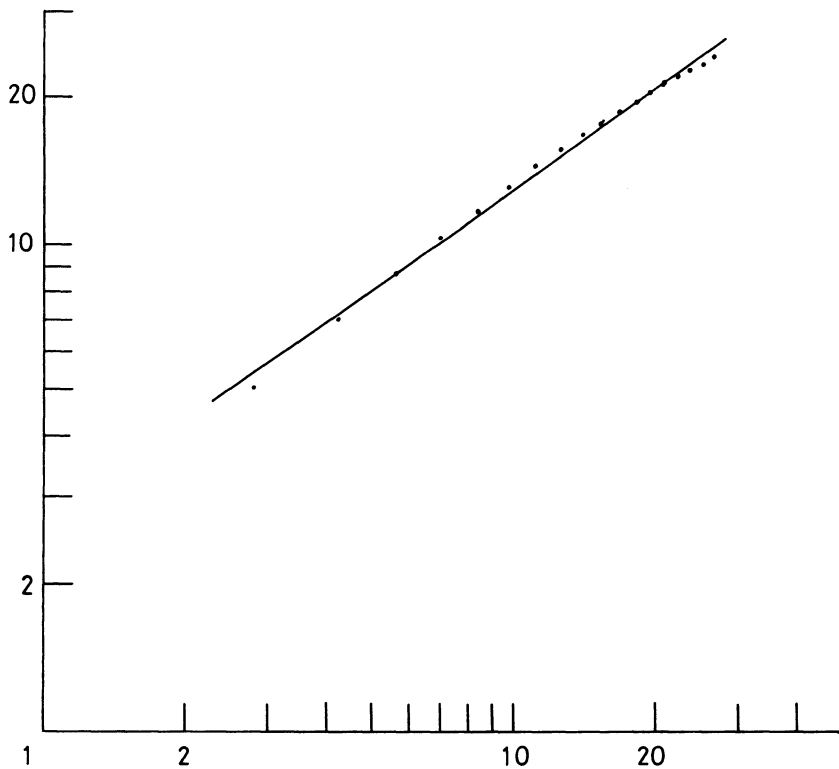

FIG. 16. Plot on log-log scales of the curve of the inner surface of the tholos tomb of the Treasury of Atreus at Mycenae (east side)

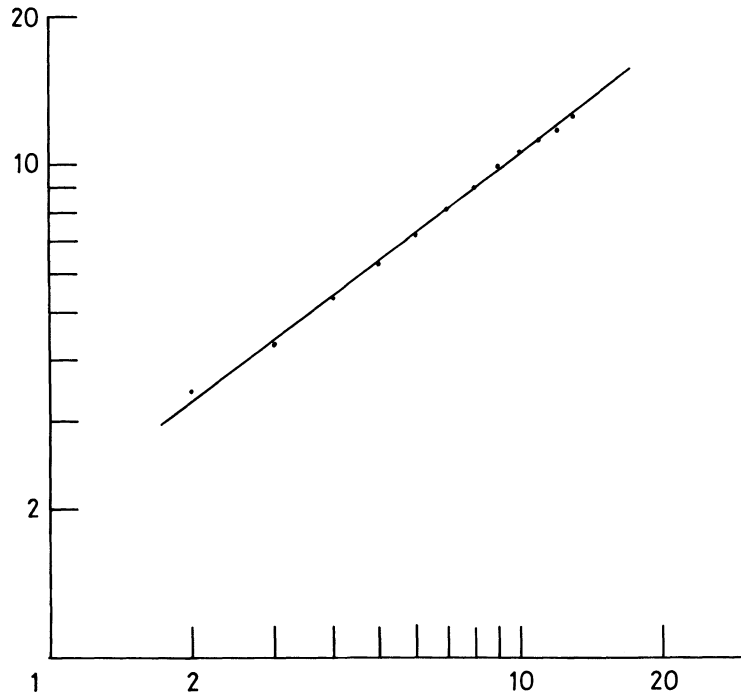

FIG. 17. Plot on log-log scales of the curve of the inner surface of the Tomb of the Genii at Mycenae (average)

of the dome, i.e., close to the join of the dome and the bottom half of the tholos. As we remarked in section IV, the slope in the bottom half is less acute than in the dome).

The values of the exponent d in $y = cz^d$ are given by the slopes of the straight lines in the log-log graphs. The five values obtained by least-squares method in the five cases are to the nearest 0.01:

TABLE I. *Values of d for the five tombs*

<i>Treasury of Atreus</i>	$d = 0.69$
<i>Dimini Tomb A</i>	$d = 0.67$
<i>Tomb of the Genii</i>	$d = 0.71$
<i>Karditsa</i>	$d = 0.67$
<i>Marathon</i>	$d = 0.67$

Such a high level of agreement is encouraging, and demonstrates that the *shapes* of all these tombs are essentially the same. Indeed, we show in the Appendix that the data is consistent with taking a *common value* for d for all the tholoi; we will not be too much in error if we take this common value to be $\frac{2}{3}$.

The value of d is absolute in the sense that it is independent of the units of measurement used; the constant c , on the other hand, is determined by these units. In addition its value depends on the absolute *size* of each tomb.

The five values of c measured in metres are:

<i>Treasury of Atreus</i>	$c = 2.7$
<i>Dimini Tomb A</i>	$c = 2.1$
<i>Tomb of the Genii</i>	$c = 2.0$
<i>Karditsa</i>	$c = 1.9$
<i>Marathon</i>	$c = 1.9$

The last four values for c are approximately equal, about 2, since these four tholos tombs are about the same size; while the Treasury of Atreus is almost twice as big in linear measurements and has a correspondingly large value of c .

We conclude that to a first approximation our predicted equation for the shape of the dome is correct and that all have the form

$$F(x) = cx^{\frac{2}{3}}$$

where c is constant for each tomb.

Now in order for this equation to be a solution for the shape of the curve of a dome $\delta(x)$ and β will have to satisfy equation (8) of the Appendix. Since β is constant it is deduced from this that $\delta(x) = \delta$ is also a constant independent of x . Notice that the equation (8) does not involve the constant c . It states a relationship between δ and β (see FIG. 10 for the meaning of these constants). For various values of $\delta \geq 0$ the corresponding values of β can be obtained. These values are shown in TABLE 2.

TABLE 2. *Table of values of δ and β for $d = \frac{2}{3}$ where the structure is covered by an earthen mound*

δ	β
0	0.32
0.23	0.50
0.36	0.75
0.43	1

Thus if the line of force runs down the inner face of the dome then $\beta = 0.32$, that is to say that the stone course must have a horizontal depth of about one-third of its inner radius. On the other hand, if $\delta = 0.36$ then β must be $\frac{3}{4}$, much larger (FIG. 18). Evidently the larger β the more stone is needed to build the tomb. The collapsed tomb at Thorikos, III (our only guide in this matter), has a value of β between $\frac{1}{2}$ and 1; so perhaps δ lay somewhere between 0.2 and 0.43.

In fact δ must in practice be greater than 0. For the dome largely rests on a cylinder of stone courses (FIG. 10). Hence for the whole structure to be stable, and not just the dome, the line of thrust must be within the masonry right down to the bottom course lying on the ground. As a first reasonable estimate this will be ensured if the vertical line of thrust of the dome on its bottom course falls within the bottom course of the whole tomb. This is illustrated in FIG. 18 where we have assumed that a value of $\delta = 0.36$ ensures the over-all stability.

It is of interest to compare this with the case where the vault is built entirely of stone and no earthen mound covers the structure. In these circumstances, and again for $d = \frac{2}{3}$, the following readings are derived:

TABLE 3. *Table of values of δ and β for $d = \frac{2}{3}$ where the structure is not covered by an earthen mound*

δ	β
No value possible	0.5
0	0.53
0.21	1
0.30	1.5
0.34	2.0

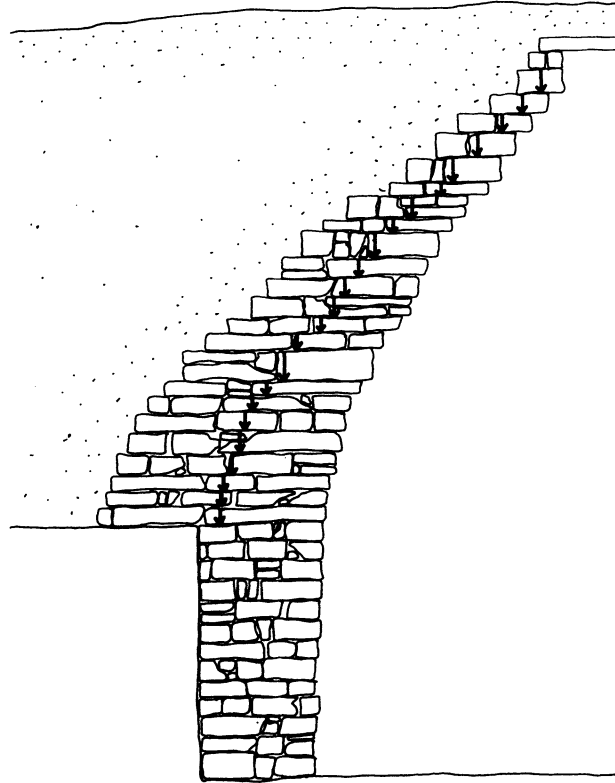

FIG. 18. The line of thrust in a tholos tomb's wall with $\beta = \frac{3}{4}$ and $\delta = 0.36$

It can be seen that considerably more stone is needed to effect the same value of δ . If $\beta = \frac{1}{2}$ then a stable structure built on the lines suggested is impossible.

VIII. INCLINATION OF COURSES AND SLIPPING

We shall now suppose that the courses are inclined (FIG. 19). Even if originally the courses were built horizontal they could have become inclined by, for example, settlement of the foundations or in some of the courses. Say as in FIG. 19 the k th course, which may be the lowest course of the dome, is inclined at an angle θ to the horizontal. Here we shall consider, albeit in a simple manner, whether there is a danger that sliding might take place at this level. That is to say, whether the k th course will tend to move horizontally outwards over the $(k+1)$ th course. One of the fundamental assumptions made hitherto was that such sliding does not take place. (Of course, the scheme given in FIG. 19 is idealized but it, nevertheless, portrays the principle involved.)

When the courses are inclined the dome of the tomb acts in a fully three-dimensional manner. Consistently with the previous line of approach, adjacent wedges can be thought to act on each other by means of interlocking stones, friction, and other such forces (FIG. 20).

Consider the stone course in our wedge. A column of earth C_k acts vertically at its end, and there is the course's own weight. Let the resultant of these two be the vertical force T_k (FIG. 20). It can be resolved into two perpendicular forces: f_k acting inwards along the k th course and N_k acting normally to it. If no movement takes place within the k th course the force f_k

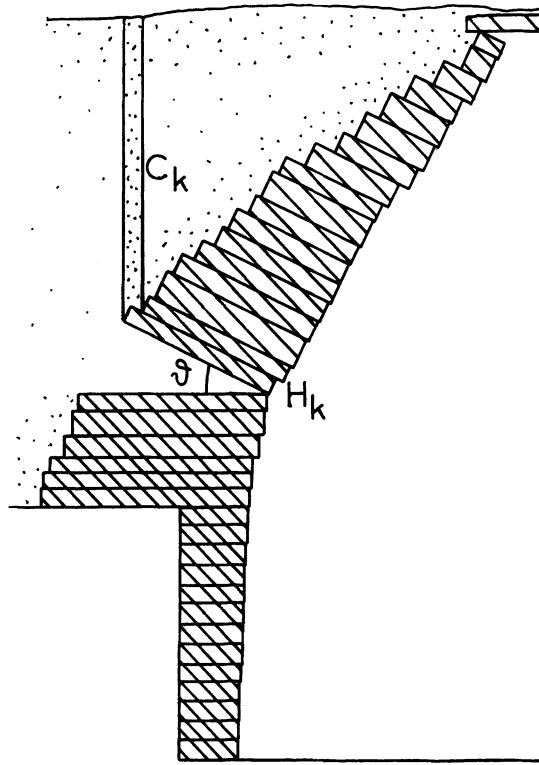

FIG. 19. Section through a tholos tomb with sloping courses

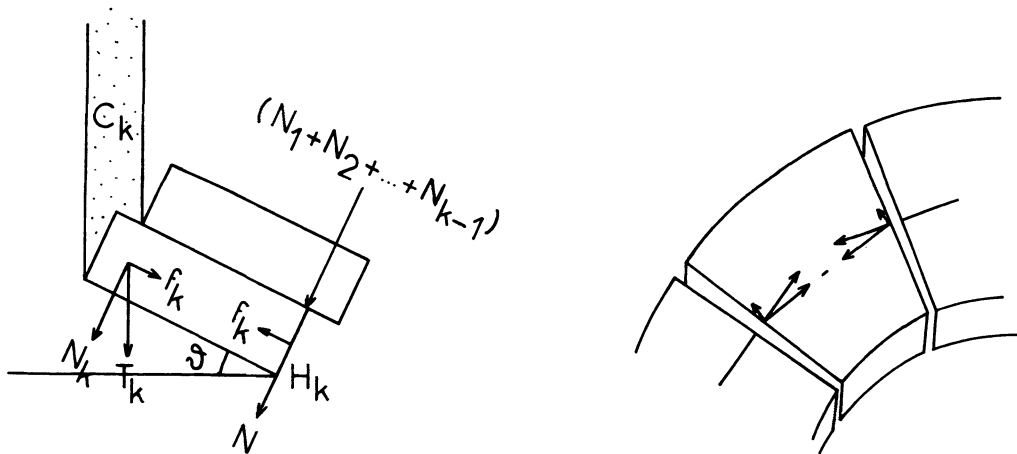

FIG. 20. Vertical forces acting on the k th course, horizontal forces from adjacent wedges acting on the k th course (ring effect)

must be opposed by a force f_k which is equal but opposite. This opposing force f_k will be the result of friction between adjacent courses and the 'ring effect' as the ring tends to push inwards and tightens (FIG. 20).

The force N_k is then left acting normally to the k th course. In a similar manner we are left with the forces N_1, N_2, \dots, N_{k-1} each acting normally to its respective course. On the

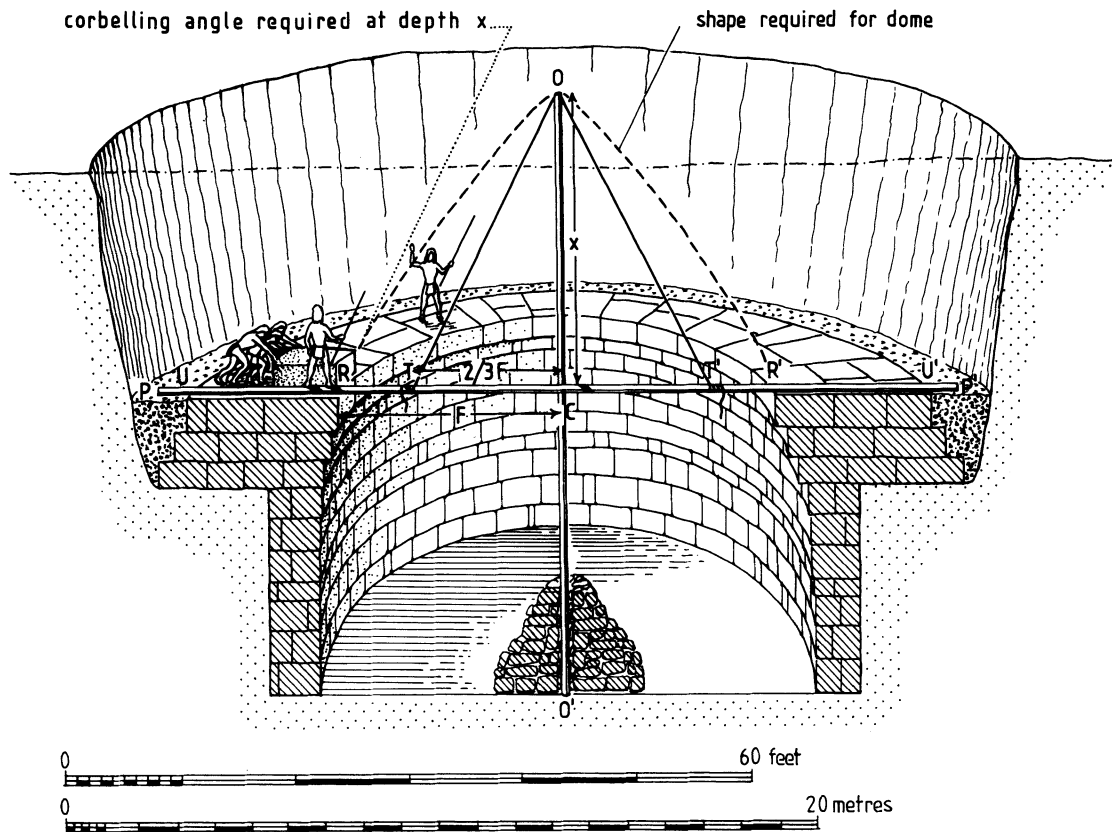

FIG. 21. A method to give the changing slope of the dome of a tholos during construction

assumption that all these courses lie at an angle θ to the horizontal, there will be a force $N = N_1 + N_2 + \dots + N_{k-1} + N_k$ acting at an angle θ to the horizontal $(k+1)$ th course. It is assumed, therefore, that settlement has taken place to the $(k+1)$ th course and that there has been a small outward movement at this level, so that a hinge has formed between the k th and the $(k+1)$ th courses at H_k . It follows that the resultant N will act through this point H_k (FIG. 19) and that all the compressive forces on the $(k+1)$ th course act at the inner face of the tomb. Elsewhere within the $(k+1)$ th course compressive forces will be low. In these circumstances there is a danger of the k th course sliding over the $(k+1)$ th course if the angle θ is close to the angle of friction for drystone on drystone; this is about 25° .³⁹ Hence sliding will not be a danger and the structure will remain stable, provided that at all places the angle of inclination is markedly less than 25° . It is noteworthy that some of the courses in the collapsed tomb at Thorikos (FIG. 4) are inclined at an angle approaching this magnitude.

IX. A SIMPLE METHOD TO CONSTRUCT THE DOME OF A THOLOS TOMB

The shape $F(x) = cx^{\frac{3}{2}}$ of the inner surface of the dome can be built in the following simple manner (FIG. 21). The builders' problem is to corbel at the correct angle as the courses are laid one on top of the other, and as the angle of slope of the interior surface changes from course to course. Assume that the over-all height of the tomb has been decided beforehand,

³⁹ O. W. Eschbach, *Handbook for Engineering Fundamentals*, 3rd edn. (1975) 480.

say approximately equal to the diameter of the tomb. A straight pole ($O-O'$) of the height required is raised at the centre of the tomb. Attached to the top of the pole are two ropes. A second pole ($P-P'$), greater in length than the diameter of the tomb, is laid crosswise; and a mark is made at its centre C . Construction has reached that stage where the dome is to start (which we have taken as level with the lintel). The cross-pole is placed across the diameter and its centre mark C aligned against the centre pole $O-O'$. The radius of the dome at that course is marked at R and R' . Two thirds of the distance CR is measured out on the cross-pole and marked at T and T' : giving $CT = CT' = \frac{2}{3}CR$. The strings suspended from O are secured at T and T' respectively. A line parallel to OT gives at R the correct angle of corbelling for this level; and similarly to OT' for the angle at R' . The horizontal pole $P-P'$ is gradually turned round the level through 180° and the new course built. Earth is packed round the outer radius of this newly constructed course to keep the stones from moving. Once this course is complete the whole procedure is repeated at the next higher course. If the course thickness Δ is small a few courses could be built at this angle without affecting the accuracy. A mathematical demonstration that this method gives the desired shape is given in the Appendix. For the builders to apply this method they need only an ability to estimate a proportion of $\frac{2}{3}$ and to build one slope parallel with another. The horizontal thickness of the courses RU can also be calculated provided that the proportion β is known since $RU = \beta CR$. For β such as $\frac{1}{3}$, $\frac{1}{2}$, or 1 no problem arises. We are not asserting that this was the method of constructing the inner shape of the dome but only that there is at least one method by which it can be effected with simple ideas. (This may not have been obvious given the nature of the curve.)

X. CLOSING REMARKS

Insofar as we have considered only one aspect of the architecture of the tholos tomb this is not the place to review the long-debated and intricate question of the origin of the tomb type.⁴⁰ Nevertheless the particular problem of when and in what circumstances there developed the specific technical skill of corbelling across such wide spaces is perhaps germane. The general tendency in recent years has been to rule out the possibility that the circular Cretan tombs of the Mesara type were vaulted in stone. Our analysis supports this conclusion. In the case where the tomb was constructed as suggested but where there is no covering earthen mound we have shown, in TABLE 3, that for stability the ratio of the thickness of the wall to the radius of the tomb (β) must be at least 0.53. Possibly a more realistic figure, and that suggested in practice at Thorikos, would be about $\beta = 1$; that is to say a wall as thick or thicker than the radius of the tomb at any given level. We can apply this test by converting into Pelon's *indice de solidité* (effectively $1/\beta$).⁴¹ For stability the *indice* will need to be less than 1.85, which is true of only twenty-six of the forty-four cases listed by Pelon; for $\beta = 1$ the *indice* must show less than 1, which is true in only one case out of the forty-four. It must be stressed that the thickness of the walling at the base of a Cretan circular tomb cannot be compared with the thickness at the base of a Mycenaean tholos tomb. As the Cretan tombs are built largely above ground the most concave part of their vault, the 'dome' of our analysis, could not spring from a ledge of bedrock or from a packed-earth foundation.

The same conclusion can be reached by another route. Let us for the moment suppose that the Cretan circular tombs were vaulted in stone, in a manner similar to the tholos tombs. Now the Cretan tombs contained in most cases a large number of burials, which are good

⁴⁰ Again an up-to-date and thorough survey can be found in Pelon op. cit. 442 f.; cf. also Hood's important article in

Antiquity 34 (1960) 166-76.

⁴¹ Pelon, op. cit. 53 and Table I, pp. 474-5.

grounds for suggesting that they were in use over a long period of time. Furthermore, if the connection between Cretan- and Mycenaean-built tombs is direct, then the Cretan tombs must have lasted in a *good state* into the Mycenaean period. These arguments indicate that the Mesara-type tombs were stable stone structures, and that they would certainly have satisfied the 'generation law' (see above). This being so the safe law tells us that under continued similar conditions the Mesara-type structures should have lasted as well as the Mycenaean and Late Minoan tholos tombs (we take into account here the fact that the Cretan circular tombs were built largely above ground). Perhaps a measure of the outcome of these similar conditions (earth-tremors, etc.) can be gauged from their effects on the Mycenaean and Cretan tholos tombs: about eight of a known ninety-nine Mycenaean tombs, and five of about eleven Late Minoan ones are still substantially intact. But none of the Cretan tombs are anywhere close to being intact if they were domed. Consequently, the 'safe law' allows us to conclude that, contrary to our initial assumption, the early Cretan circular tombs were not domed in stone.

If the skill of building corbelled stone domes finds no predecessor on Crete, it is reasonable to conclude that the technique was first developed on the mainland of Greece, and specifically in response to a demand for monumental family vaults. One of the least-expected results of our enquiry has been the discovery that in all five tombs almost identical shapes for the dome have been employed. The tombs measured are almost as widely separated in date and in space as one could hope to find. Their close similarity, therefore, suggests that the method for deciding the curvature of the vault was the same in all cases. This must be so whether the curvature was established in the manner we have put forward or by some other method. It would seem to follow that all the tombs follow the same tradition and were derived from a single origin. Thanks largely to the series of campaigns conducted by the Greek Antiquities Service and Archaeological Society it has become ever clearer that the tomb type was first developed in the area of the south-west Peloponnese.⁴² In the present state of publication, however, it is impossible to consider these early tombs in detail; some have clearly suffered severely from erosion.⁴³ Is it possible, all the same, to speculate further about the genesis of the corbelled dome? Hood has, with reason, stressed the early 'minoanization' of the south-west Peloponnese,⁴⁴ and Pelon has observed a strong Minoan influence on the important tombs at Peristeria.⁴⁵ Could it be that although the demand for the tombs was a mainland development and the funerary beliefs and customs which the tombs answered were Mycenaean, that nevertheless the architects were Minoan craftsmen? The question is almost unanswerable from the archaeological evidence. All the same a few arguments can be put forward to the effect that tholos tombs would not spring naturally from the Minoan architectural tradition.

First of all the suggestion that the Minoans did not vault their own tombs until a period of strong Mycenaean influence, indeed probable Mycenaean rule on the island, is telling though not conclusive.⁴⁶ Moreover the general tendency of Minoan monumental buildings during the New Palace period was to favour sawn ashlar masonry.⁴⁷ It is noteworthy that when the vaulted tomb was first introduced into Crete it was constructed in the squared masonry of the Minoan tradition, not the irregular schist or cyclopean style of mainland Greece. Ashlar masonry is not found in the earliest Mycenaean tombs but is a development

⁴² Ibid. 377f.

⁴³ Ibid. 300 and n. 1.

⁴⁴ *Antiquity* 34 (1960) 168, 174.

⁴⁵ Pelon, *op. cit.* 449.

⁴⁶ The Royal Tomb at Isopata, *Archaeologia* 52 ii (1905)

526-62; the Kephala tholos tomb Pelon, *op. cit.* 422 f.; Tomb 1 at Isopata, *Archaeologia* 65 (1913-14) 1-14. All three date to LM II.

⁴⁷ See J. W. Shaw in *Annuario* 49 (n.s. 33) (1971) 83 ff.; on the Temple Tomb at Knossos see *P. of M.* iv 2, 967-8.

found in the later tombs such as tomb 1 at Peristeria and in the Tomb of Aegisthus at Mycenae.⁴⁸ It has been maintained that Minoan architects used a standard unit of measure in constructing their buildings.⁴⁹ Our suggested method of building a tholos tomb makes no appeal to such a unit. Apart from the circular tombs there is little in Minoan architecture which might be held to anticipate the Mycenaean buildings. The primitive relieving triangle observed in Tomb III at Megaloi Skinoi was an isolated experiment⁵⁰ in a tomb whose construction is said to date as early as EM I; there is no evidence of a later follow up of this experiment. On the contrary the Minoan answer to the weight of masonry over the entrance-way was to thicken the lintel at its centre. Clearly the greatest strain is applied at the centre of the beam, the point furthest from the jambs, and a thickened lintel will strengthen the block at precisely that point where the bending moment is greatest.⁵¹ The Mycenaean answer was not, in the tholos tombs, to strengthen the lintel, but to prevent the weight from falling on the lintel: a totally different approach. A second monument which might distantly be felt to anticipate the tholos tomb is the Viaduct at Knossos.⁵²

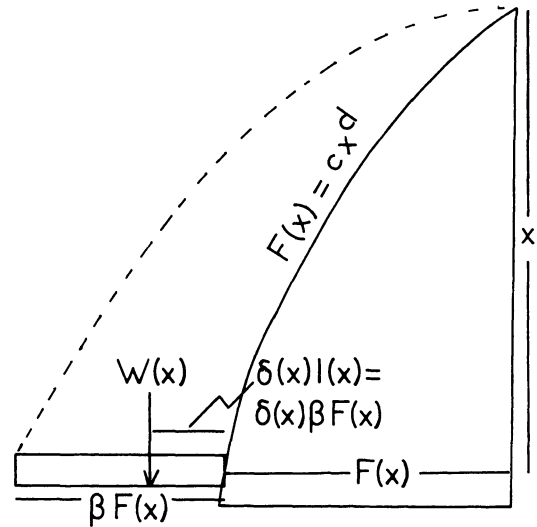

FIG. 22. Functions and constants involved in the solution (continuum variable)

The suggestion, and it is no more, that the piers supported corbelled arches is not unreasonable, and a date in LM I more probable than any other, yet even granted these points a connection with the technique of corbelling a tholos tomb is hopelessly remote.

In brief we would suggest that the skill in engineering and the boldness of conception which inspired these monuments owe nothing to foreign technology. The technique of corbelling across such wide spaces was a Mycenaean invention conceived at the very earliest state of that civilization.

W. G. CAVANAGH
R. R. LAXTON

APPENDIX

The assumptions on which this analysis of the structure of the tomb's dome is based have already been given. The notation is as in FIG. 10. The courses are taken to be horizontal and the dome is sectioned into wedges. Conditions for the stability of each wedge are established. Thus the 'ring-effect' is ignored, and our approach is to be considered conservative. The angle which each wedge makes at the centre is taken as 2α (FIG. 10) and is supposed to be so small that $\sin \alpha$ is approximately α .

The line of action (FIG. 22) of the total weight $W(n)$ of the topmost $(n+1)$ levels $(0, 1, \dots, n)$ on the base of the n th stone course acts at a distance $\delta(\Delta n) l(\Delta n)$ from its innermost circumference, that is the interior surface of the tomb at that level. All the forces considered

⁴⁸ It is this Minoan feature of Tomb 1 at Peristeria which carries the Minoan mason's marks: *Ergon* 1960 154 fig. 168.

⁴⁹ J. W. Graham, *The Palaces of Crete* (1967) 222-9, cf. also Shaw in *Annuario* 49 (N.S. 33) (1971) 74 n. 4.

⁵⁰ *A. Delt.* 22 (1967) chron. 482 and pl. 357. The photograph

does not reveal the nature of the relieving triangle.

⁵¹ It will be apparent that we cannot go along with Branigan's explanation, *The Tombs of Mesara* 35, that the reason for the triangular elevation of the lintel was to disperse the pressure.

⁵² *P. of M.* ii 93 ff.

are vertical and so parallel with the vertical plane AA (FIG. 10). The distance of the line of action of $W(n)$ from AA is $F(\Delta n) + \delta(\Delta n) l(\Delta n)$. We calculate this distance in terms of the sum of the effects of each of the $(n+1)$ segments of the levels $k=0, 1, \dots, n$ within the wedge. This is effected by summing the first moments about AA of these $(n+1)$ segments and dividing the sum by the total weight. The result gives the distance of the centre of gravity of $(n+1)$ levels from AA ,⁵³ which must equal $F(\Delta n) + \delta(\Delta n) l(\Delta n)$.

The segment within the wedge of the k th level, that is to say the stone and earth, supported by the n th (stone) course's segment within the wedge is a segment of an inner annulus of stone between arcs of radii $F(\Delta k)$ and $F(\Delta k) + l(\Delta k)$, and a segment of an outer annulus of earth between the radii $F(\Delta k) + l(\Delta k)$ and $F(\Delta n) + l(\Delta n)$, which is the outer radius of the n th course.

The first moment of this segment about AA is:

$$\begin{aligned} \frac{2}{3} \Delta w(S) \{ [F(\Delta k) + l(\Delta k)]^3 - F(\Delta k)^3 \} \sin \alpha + \\ + \frac{2}{3} \Delta w(E) \{ [F(\Delta n) + l(\Delta n)]^3 - [F(\Delta k) + l(\Delta k)]^3 \} \sin \alpha \end{aligned} \quad (1)$$

and the weight is:

$$\begin{aligned} \Delta w(S) \{ [F(\Delta k) + l(\Delta k)]^2 - F(\Delta k)^2 \} \alpha + \\ + \Delta w(E) \{ [F(\Delta n) + l(\Delta n)]^2 - [F(\Delta k) + l(\Delta k)]^2 \} \alpha. \end{aligned} \quad (2)$$

Here $w(S)$ and $w(E)$ are weights per unit volume of stone and earth, respectively. Hence the distance $F(\Delta n) + \delta(\Delta n) l(\Delta n)$ of the centre of gravity from AA of the first $(n+1)$ segments of levels is, recalling that $\sin \alpha \simeq \alpha$:

$$\begin{aligned} F(\Delta n) + \delta(\Delta n) l(\Delta n) \\ = \frac{2}{3} \frac{w(S) \sum_{k=0}^n \{ [F(\Delta k) + l(\Delta k)]^3 - F(\Delta k)^3 \} \Delta + w(E) \sum_{k=0}^n \{ [F(\Delta n) + l(\Delta n)]^3 - [F(\Delta k) + l(\Delta k)]^3 \} \Delta}{w(S) \sum_{k=0}^n \{ [F(\Delta k) + l(\Delta k)]^2 - F(\Delta k)^2 \} \Delta + w(E) \sum_{k=0}^n \{ [F(\Delta n) + l(\Delta n)]^2 - [F(\Delta k) + l(\Delta k)]^2 \} \Delta} \end{aligned} \quad (3)$$

In order to get a simple analytic solution we assume that:

- (a) $l(\Delta k) = \beta F(\Delta k)$ for all $k = 0, 1, 2, \dots$, where β is a constant independent of k and
- (b) $w(E) = w(S)$ (see remark in section VI).

With these simplifications the above equation becomes:

$$\begin{aligned} F(\Delta n) = \frac{2}{3} \frac{1}{(1 + \delta(\Delta n)\beta)} \frac{[(1 + \beta)^3 - 1] \sum_{k=0}^n F(\Delta k)^3 \Delta + (1 + \beta)^3 n \Delta F(\Delta n)^3 - (1 + \beta)^3 \sum_{k=0}^n F(\Delta k)^3 \Delta}{[(1 + \beta)^2 - 1] \sum_{k=0}^n F(\Delta k)^2 \Delta + (1 + \beta)^2 n \Delta F(\Delta n)^2 - (1 + \beta)^2 \sum_{k=0}^n F(\Delta k)^2 \Delta} \\ = \frac{2}{3} \frac{1}{(1 + \delta(\Delta n)\beta)} \frac{(1 + \beta)^3 n \Delta F(\Delta n)^3 - \sum_{k=0}^n F(\Delta k)^3 \Delta}{(1 + \beta)^2 n \Delta F(\Delta n)^2 - \sum_{k=0}^n F(\Delta k)^2 \Delta} \end{aligned} \quad (4)$$

We now suppose that Δ , the vertical thickness of each course, is small compared with the overall height of the dome and turn Δk into a continuous variable varying from 0 to $x (= \Delta n)$.

⁵³ Morgan and Williams, op. cit.

Then the summations in the above expression may be replaced by integrals and we are left with the final equation:

$$F(x) = \frac{2}{3} \frac{1}{(1 + \delta(x)\beta)} \frac{(1 + \beta)^3 x F(x)^3 - \int_0^x F(z)^3 dz}{(1 + \beta)^2 x F(x)^2 - \int_0^x F(z)^2 dz} \quad (5)$$

for the shape of the inner surface of the tomb.

We shall try solutions of this equation of the form:

$$F(x) = cx^d, \text{ where } c \text{ and } d \text{ are constants.}$$

Then

$$\int_0^x F(z)^2 dz = c^2 \int_0^x z^{2d} dz = \frac{c^2}{(2d+1)} x^{2d+1}$$

and

$$\int_0^x F(z)^3 dz = c^3 \int_0^x z^{3d} dz = \frac{c^3}{(3d+1)} x^{3d+1}.$$

Substituting for $F(x)$ and for these integrals in the equation gives

$$\begin{aligned} cx^d &= \frac{2}{3} \frac{1}{(1 + \delta(x)\beta)} \frac{(1 + \beta)^3 c^3 x^{3d+1} - \frac{c^3}{(3d+1)} x^{3d+1}}{(1 + \beta)^2 c^2 x^{2d+1} - \frac{c^2}{(2d+1)} x^{2d+1}} \\ &= \left[\frac{2}{3} \frac{1}{(1 + \delta(x)\beta)} \frac{(1 + \beta)^3 - \frac{1}{(3d+1)}}{(1 + \beta)^2 - \frac{1}{(2d+1)}} \right] cx^d. \end{aligned} \quad (6)$$

Hence $F(x) = cx^d$ is a solution of the equation if

$$\frac{2}{3} \frac{1}{(1 + \delta(x)\beta)} \frac{(1 + \beta)^3 - \frac{1}{(3d+1)}}{(1 + \beta)^2 - \frac{1}{(2d+1)}} = 1. \quad (7)$$

Note that this expression is independent of the constant c . It connects β , $\delta(x)$, and the exponent d .

It has been found from the measurements (FIGS. 13 to 17 and section VII) that the inner radius $F(x)$ of each tomb considered does indeed satisfy an equation of the form $F(x) = cx^{\frac{2}{3}}$ (see below for the statistical analysis). For $d = \frac{2}{3}$ the last expression becomes:

$$\frac{2}{3} \frac{1}{(1 + \delta\beta)} \frac{(1 + \beta)^3 - 0.33}{(1 + \beta)^2 - 0.43} = 1. \quad (8)$$

The expression connects the constants β and δ . Observe that we have written $\delta(x) = \delta$, a constant, which it must be since β is a constant. This equation was used in constructing TABLE 2 for corresponding values of β and δ .

By way of contrast we shall consider also the case where no earthen mound covers the

tomb. The above argument suitably modified, by taking $w(E) = 0$ and dropping assumption (b), leads to the expression:

$$\frac{2}{3} \frac{1}{(1+\delta\beta)} \frac{\{(1+\beta)^3-1\}(2d+1)}{\{(1+\beta)^2-1\}(3d+1)} = 1. \quad (9)$$

For $d = \frac{2}{3}$ this becomes

$$\frac{14}{27} \frac{1}{(1+\delta\beta)} \frac{(1+\beta)^3-1}{(1+\beta)^2-1} = 1. \quad (10)$$

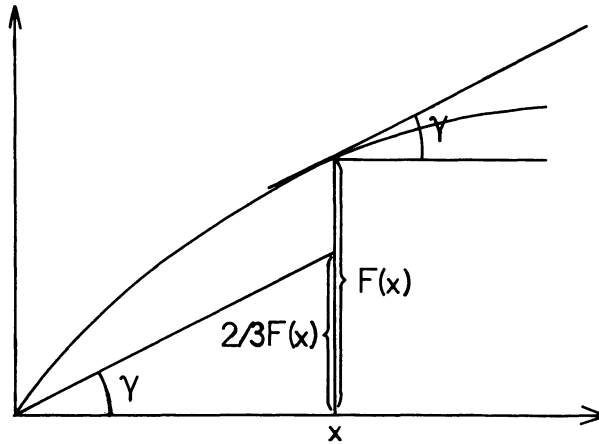

FIG. 23. Method of determining the slope of the inner surface of a tholos tomb at any given point

This equation was used in constructing TABLE 3 for corresponding values of β and δ .

Finally in support of the suggested method of building (section IX) by which the slope of the vault might have been achieved we can argue that if $F(x) = cx^d$, then on differentiating $F'(x) = dcx^{d-1} = dF(x)/x$. Thus the slope of the curve at distance x below the top of the tomb is parallel to $dF(x)/x$. For $d = \frac{2}{3}$ this gives an easy method for estimating the slope of the corbelling at any given depth x below the required height of the tomb.

Assumption (iii) of our simplification for the purposes of analysis (section VI) was that the earth covered the tomb to a depth Δ . In practice this depth varies from tomb to tomb. However, say that the earth has a depth equal to $m\Delta$ (i.e. m thicknesses of Δ) above a tomb. Then equation (7) will be replaced by

$$\frac{2}{3} \frac{1}{(1+\delta(x)\beta)} \frac{(1+\beta)^3 - \frac{1}{3d+1} + \frac{m}{x}}{(1+\beta)^2 - \frac{1}{2d+1} + \frac{m}{x}} = 1. \quad (11)$$

The solutions for this equation will not be significantly different from those for (7) provided m is not too large (and in any event, of decreasing significance as x increases).

Finally we turn to the statistical analysis of fitting curves of the form $F = cx^d$ to the data from the five tombs. One approach, that adopted in section VII, is to determine the best fit, by the least-squares method, of a linear equation of the form $\log F = c + d \log x$, where c and d are constants. In general, c and d will be different for different tombs. However, we wanted

to consider the idea that the value of d is the *same for all five tombs*. (i.e., d is to be held constant from tomb to tomb) with only c allowed to vary from tomb to tomb. Dr. Triggs showed that this later model fitted the data very well indeed and that there is an insignificant improvement (as measured by the F-statistic) in fitting the data with both c and d varying from tomb to tomb. Hence we feel justified in taking a common value of d for all five tombs; the best fitting common value turns out to be 0.68 (actually, the 95 % confidence interval for d is 0.667 to 0.691).

An alternative approach is to fit curves of the form $F = cx^d$ directly, i.e., without first linearizing by taking logarithms. Here the residual sum of squares was minimized (assuming a common value of d) at 0.65, slightly less than the value obtained by the linear approach. (The reason for this slight difference is that the linear approach assumes the errors are multiplicative whilst the direct one assumes that they are additive.)

Not only did we consider that the value of d should be the same for all five tombs, but also that its value should be a simple fraction. This, of course, is because we are offering a simple method of construction for the tombs. As a consequence of the above remarks, we feel justified in taking a common value of $\frac{2}{3}$ for the exponent d .

ACKNOWLEDGEMENTS

It is with pleasure and gratitude we record help given by many. Particular thanks are due to members of the Greek Archaeological service who have fostered the project—especially Dr. Hourmouziades, Ephor at Volos, and Mrs. Chrystallis, Ephor at Nafplion—and to the Ephoreia of Attica. The Committee of the B.S.A. granted W.G.C. the Macmillan Studentship, during the tenure of which the tombs were measured. The Director and staff of the School were unfailing in their assistance. Thanks are owed to Lord William Taylour and Dr. John Camp of the Agora Excavations for the loan of equipment. Many individuals have given generously of their time; in particular Mr. Michael Davies and Mr. Lazaros Koukouletsos. Special thanks are due to Dr. Jim Coulton who has offered invaluable advice from the project's inception and who saved the final text from a number of errors. Professor Heyman has also read and commented on the text, and Mr. Paul Halstead helped in this role. Finally, we thank Mr. N. Hunt, who checked our calculations in TABLE 1, and Dr. C. M. Triggs, who provided the statistical analysis in the Appendix. The views expressed and the errors that remain are, of course, those of the authors.

TABLE 4. *Table of readings describing the curve of the vault of the Treasury of Atreus at Mycenae*

The 'dome' is taken from 2.8 to 26.6. Only the east side is used in the analysis; according to Donaldson the west side is distorted. Measurements are given in centimetres at a scale of 1 : 25.

Depth below capstone (1 : 25)	Radius to east side (1 : 25)
0 cm	3.36 cm
2.8	5.04
4.2	7.0
5.6	8.68
7.0	10.36
8.4	11.76
9.8	13.16
11.2	14.56
12.6	15.68*
14.0	16.80
15.4	17.64
16.8	18.76
18.2	19.6
19.6	20.44
21.0	21.28
22.4	22.12
23.8	22.68
25.2	23.24
26.6	24.08†
28.0	24.64
29.4	25.2

* Top of the relieving triangle.

† Top of the lintel block.

TABLE 5. *Table of readings describing the curve of the vault of tholos tomb A at Dimini*

The 'dome' is taken from 2.4 to 19.2. The average of the two radii is used in the analysis. Measurements are given in centimetres at a scale of 1 : 25.

Depth below capstone (1 : 25)	Radii to east and west sides		Average Av
	R_E	R_W	
2.4 cm	3.36 cm	4.56 cm	3.96 cm
3.6	4.2	5.64	4.92
4.8	5.16	6.72	5.94
6.0	5.52	7.44	6.48
7.2	6.48	8.76	7.62
8.4	8.16	9.6	8.88
9.6	9.12	10.8	9.96
10.8	9.72	11.76	10.74
12.0	10.56	12.72	11.64
13.2	11.16	13.2	12.18
14.4	11.52	14.28	12.9
15.6	11.88	14.76	13.32
16.8	12.36	15.48	13.92
18.0	12.96	15.72	14.34
19.2	13.2	16.08	14.64

TABLE 6. *Table of readings describing the curve of the vault of the tholos tomb at Karditsa*

The 'dome' is taken from 1 to 16. The average of the two radii is used in the analysis. Measurements are given in centimetres at a scale of 1:25.

Depth below capstone (1:25)	Radii to north and south sides		Average Av
	R_N	R_S	
1 cm	1.1 cm	2.3 cm	1.7 cm
2	2.6	3.7	3.15
3	3.6	4.7	4.15
4	4.5	5.5	5.0
5	5.2	6.2	5.7
6	6.0	7.0	6.5
7	6.4	7.5	6.95
8	7.2	8.0	7.6
9	7.6	8.5	8.05
10	8.2	9.1	8.65
11	9.2	9.6	9.4
12	9.7	10.1	9.9
13	10.3	10.5	10.4
14	10.8	11.0	10.9
15	11.5	11.7	11.6
16	12.1	12.4	12.50

TABLE 7. *Table of readings describing the curve of the vault of the tholos tomb at Marathon*

The 'dome' is taken from 4.8 to 19.2. The average of the two radii is used in the analysis. Measurements are in centimetres at a scale of 1:25.

Depth below capstone	Radii to west and east		Average Av
	R_W	R_E	
1.6 cm	2.08 cm	2.16 cm	2.12 cm
2.4	2.88	3.2	3.0
3.2	3.68	3.92	3.8
4.0	4.16	4.64	4.4
4.8	4.8	5.36	5.08
5.6	5.28	6.0	5.64
6.4	6.4	6.72	6.56
7.2	7.28	7.12	7.2
8.0	7.76	7.68	7.72
8.8	8.0	8.16	8.08
9.6	8.4	8.88	8.64
10.4	8.64	9.2	8.92
11.2	9.12	9.84	9.48
12.0	10.08	10.08	10.08
12.8	10.64	10.48	10.56
13.6	11.04	10.96	11.0
14.4	11.52	11.44	11.48
15.2	11.9	11.68	11.76
16.0	11.9	12.0	11.95
16.8	12.08	12.24	12.12
17.6	12.48	12.32	12.4
18.4	12.72	12.48	12.6
19.2	12.8	12.56	12.68

} Restored

TABLE 8. *Table of readings describing the curve of the vault of the Tomb of the Genii at Mycenae*

The 'dome' is taken from 2 to 13. The average of the two radii is used in the analysis. Measurements are given in centimetres at a scale of 1 : 25.

Depth below the top	Radii to north and south		Average Av
	R_N	R_S	
2 cm	3.5 cm	3.4 cm	3.45 cm
3	4.4	4.2	4.3
4	5.4	5.3	5.35
5	6.3	6.2	6.25
6	7.2	7.1	7.15
7	8.0	8.1	8.05*
8	8.9	9.0	8.95
9	9.8	9.9	9.85
10	10.7	10.5	10.6
11	11.2	11.2	11.2
12	11.9	11.5	11.7
13	12.5	12.4	12.45†

* Top of the relieving triangle.

† The lintel block.