

The Annual of the British School at Athens

<http://journals.cambridge.org/ATH>

Additional services for *The Annual of the British School at Athens*:

Email alerts: [Click here](#)

Subscriptions: [Click here](#)

Commercial reprints: [Click here](#)

Terms of use : [Click here](#)

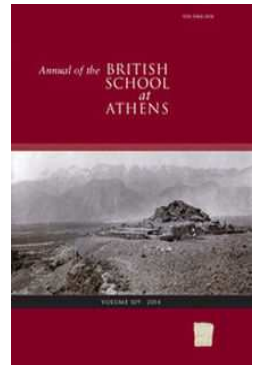

An Archaeological Survey on the South Coast of Crete, between the Ayiofarango and Chrisostomos

D. J. Blackman and K. Branigan

The Annual of the British School at Athens / Volume 70 / November 1975, pp 17 - 36
DOI: 10.1017/S006824540000650X, Published online: 27 September 2013

Link to this article: http://journals.cambridge.org/abstract_S006824540000650X

How to cite this article:

D. J. Blackman and K. Branigan (1975). An Archaeological Survey on the South Coast of Crete, between the Ayiofarango and Chrisostomos. The Annual of the British School at Athens, 70, pp 17-36 doi:10.1017/S006824540000650X

Request Permissions : [Click here](#)

AN ARCHAEOLOGICAL SURVEY ON THE SOUTH COAST OF CRETE, BETWEEN THE AYIOFARANGO AND CHRISOSTOMOS

(PLATES 5-10)

THIS report describes twelve archaeological sites discovered and briefly surveyed in September 1971 by a team from the University of Bristol, led by the writers. The work was completed in three days, following a more extended and intensive survey of the Ayiofarango catchment area.¹ Our attention was concentrated on the two harbour sites just east of the mouth of the Ayiofarango valley, at Kaloi Limenes and Lasaia, and on the evidence that they had attracted human occupation throughout antiquity (PLATE 5*a*). Nevertheless, the whole of the coastal strip from the mouth of the Ayiofarango valley to the ruined church at Chrisostomos was examined (FIG. 1), and the areas between the gorge and the sites just west of Kaloi Limenes (SC1-5) and between Kaloi Limenes and the tholoi and Roman farmstead overlooking Lasaia (SC8-9) do seem to be empty of evidence for occupation at any period before the present.

The sites, prefixed S(outh) C(oast), are numbered and described in the order in which they were recorded, which in general is from west to east. We conclude with a brief discussion of the principal points of interest which arise from the results of the survey. (M = Minoan; GR = Greek; R = Roman.)

SC1 (M?, GR) (PLATE 5*b*)

On a south-facing slope 700 m. south-west of Kaloi Limenes, remains of terrace- and possibly house-walls were noted over an area about 80 m. × 30 m. Two sherds of black-washed MM pottery were collected, but the remainder of the sherds are dated to the Hellenistic and Roman periods, and mainly to the latter. These included 3 sherds of *terra sigillata*, 2 rims of Hellenistic/Roman cooking-pots (FIG. 9, 1. 1-2)² and 6 bowl/dish rims (FIG. 9, 1. 3). Late Roman C ware and other late fabrics were notably absent. The site may be that of a moderately large Roman farmstead.

SC2 (M) (FIG. 2; PLATES 5*c-d*; 6*a-b*; 7*a*)

Some 400 m. west of Kaloi Limenes, and the same distance from the coast opposite Megalonisi, an Early Minoan tholos was found on a spur which stood north-east of site SC1. Discussion with Dr. C. Davaras confirmed that this was the same robbed tomb examined and reported by him in 1968,³ and listed in Branigan's catalogue as tholos no. 17 (Kaloi

¹ We hope to present the results of this survey and the excavation of the Early Minoan tholos at Ayia Kiriaki, in further issues of the *Annual*.

² The fabric of which these sherds were made we have called Type Fabric (henceforward TF) T. This forms one of a series of Type Fabrics which we were able to identify in a stratified sequence of four levels in the Ayiofarango catchment area by the spring at Ayia Kiriaki, see n. 1. Full details of the sequence and the Type Fabrics will be published in the Ayiofarango report. TF T is a brittle, dark purplish-brown fabric with brick-red core, recognizable as a 'cooking-pot' ware.

³ *ADelt* xxiii (1968) *Chron.* 2, 405 and pl. 367; cf. S. Alexiou, *ADelt* xxii (1967) *Chron.* 2, 483. This or the near-by tomb (SC3) are the likeliest sources of the EM II pottery 'from Kaloi Limenes, clearly from a looted prepalatial tomb', which reached Herakleion Museum in 1964: Alexiou, *ADelt* xx (1965) *Chron.* 3, 552; cf. Branigan, *The Tombs of Mesara* 172, no. 78, where the reference must be corrected (also, nos. 18-19 are less likely, being close to Lasaia). The same is probably true of many of the other EM objects which have reached the Museum and the Metaxas Collection in recent years from 'the Kaloi Limenes area': Alexiou, *ADelt* xix (1964) *Chron.* 3, 439; xx

Limenes I).⁴ It was a well-preserved tomb with an external diameter of 8.7 m. and an internal one of 4.9 m. The wall was almost 2 m. thick, and built for the most part of very large boulders, the largest of which were about $1.2 \times 1.1 \times 0.5$ m. With the careful insertion of smaller blocks, these boulders were laid in rough courses, each of which slightly overlapped the course below to produce a corbelled structure. The overhang thus produced was 0.9 m. at the point where the tomb wall was preserved to its greatest height, 2.2 m. There were two features of the tomb wall which deserve particular comment. First, the foundations were not made of large boulders but

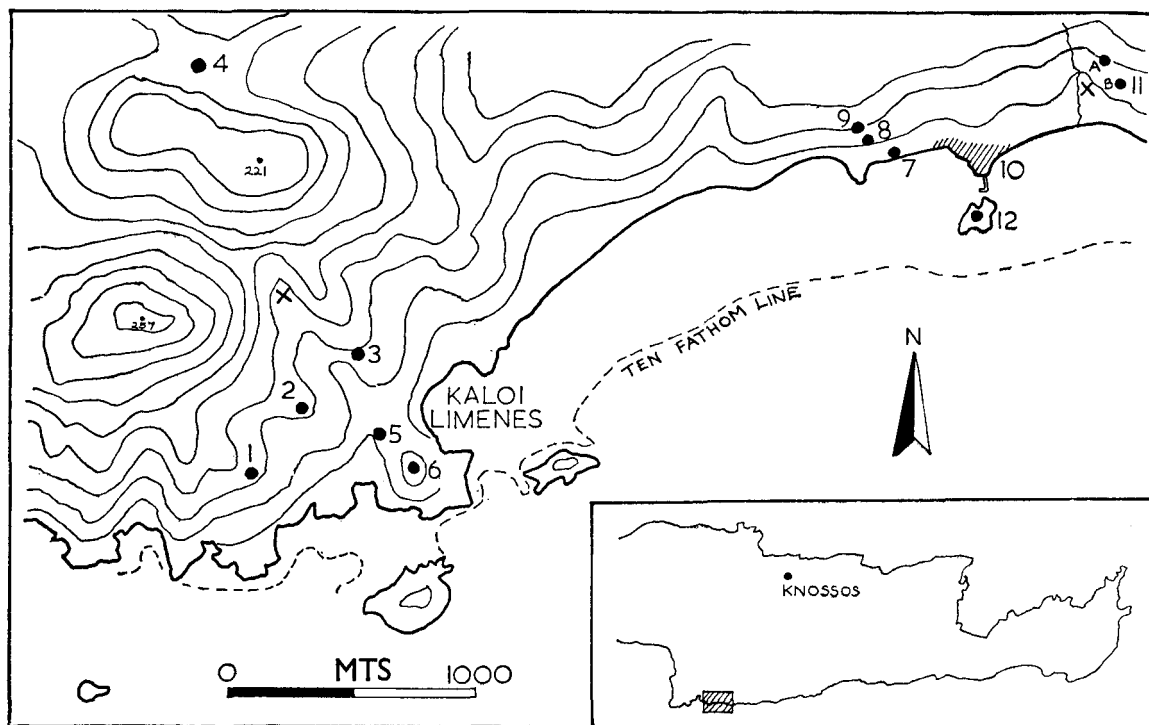

FIG. 1. The area of the survey (see n. 11 for explanation of contours). Copper sources marked X

of very small rocks and stones in a bed of clay; this *may* have been the original soil on the site, but if so, then inside the wall it had been dug away, and the floor (of trampled, whitish soil on rock as we found it) was 0.20 m. lower. Secondly, there were slabs of stone set on edge around the outside of the tomb. They were only visible around the northern half of the circumference, but the robbers' spoil-heaps completely covered the outer face of the wall on the southern side, so that we cannot be certain that they did not run all round the tomb. They may have been intended to form an orthostatic kerb (cf. for example British passage-graves), but they may equally have had a purely structural purpose. This would have been to resist the outward thrust at the base of the corbelled structure. The only other EM tholos which has produced anything similar is that excavated by us just south of Ayia Kiriaki,⁵ where there was certainly not a complete circuit of stones set edgewise. The door was set in the east side of the tomb, and

(1965) *Chron.* 3, 551; xxi (1966) *Chron.* 2, 406; xxii (1967) *Chron.* 2, 482. However, the EM tombs in the Ayiofarango catchment area cannot be excluded; cf. the seals acquired

by the Metaxas Collection whose provenance is given as Figaidakia: I. A. Sakellarakis, *ADelt* xx (1965) *Chron.* 3, 563.

⁴ *Op. cit.* 170.

⁵ See n. 1.

was of *trilithon* type, 0.75 m. high and 0.55 m. wide. Because it was nearly 2 m. deep, however, its two jambs were surmounted by two lintel slabs, instead of one; the outer slab was 1.3 × 1.0 × 0.5 m., and the inner 0.9 × 0.9 × 0.25 m. The latter was particularly interesting because it is the only example known to us where the lintel slab sat on a bed of small stones which had been carefully placed on top of each of the jambs. There is one other point of interest concerning the

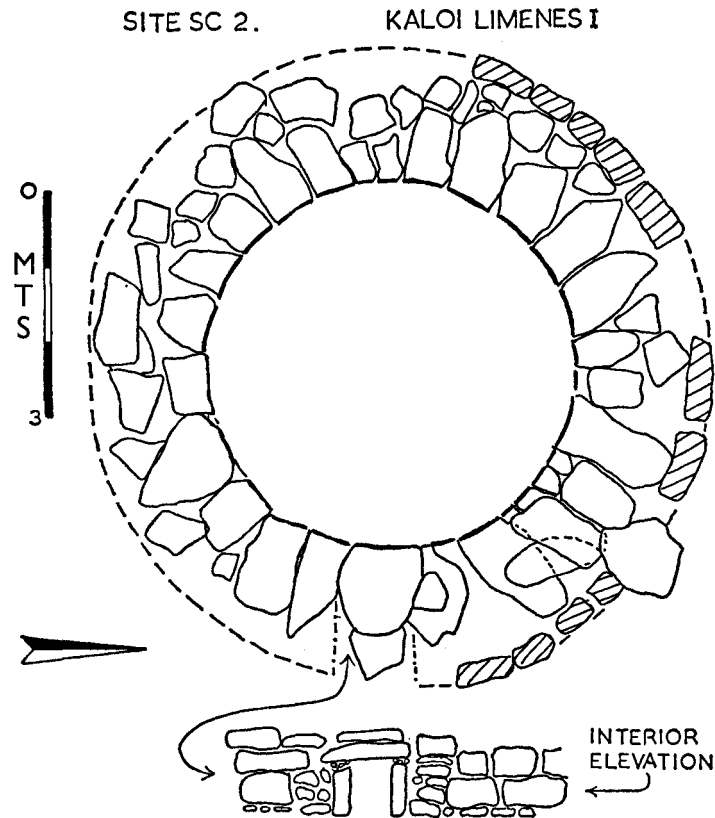

FIG. 2. Early Minoan tholos. Site SC2

doorway as a whole. In all of the tholoi we have seen and examined, the boulders on either side of the door were of about average size for that particular tomb. Here, however, the large boulders typical of the rest of the wall were missing from both sides of the door. Instead, much smaller stones were packed in; on the south side of the door four were stacked, very insecurely it appeared, one above another (PLATE 6a). One explanation is that the door was inserted, after the rest of the wall had been built, into a space which had been left for it and which proved to be somewhat too wide. An alternative possibility is that the door at some stage collapsed and the whole door area was rebuilt. As Davaras commented, there is no trace of an antechamber.

There were very few sherds to be collected. The most distinctive was a collar rim from a red-on-buff EM I spherical vessel with red chevrons. There was one other sherd of Ayios Onouphrios ware, and a brown-washed sherd probably of EM II. Bone remains were plentiful,

but all very small fragments. Some of them showed clear signs of charring, and we conclude that the tomb may have undergone at least one fumigation.

SC3 (M) (FIG. 3; PLATES 5*c*; 7*b*)

On a saddle on the first ridge west of Kaloi Limenes, about 250 m. WNW. of the village, were the remains of another tholos tomb. This had been robbed, and was almost completely

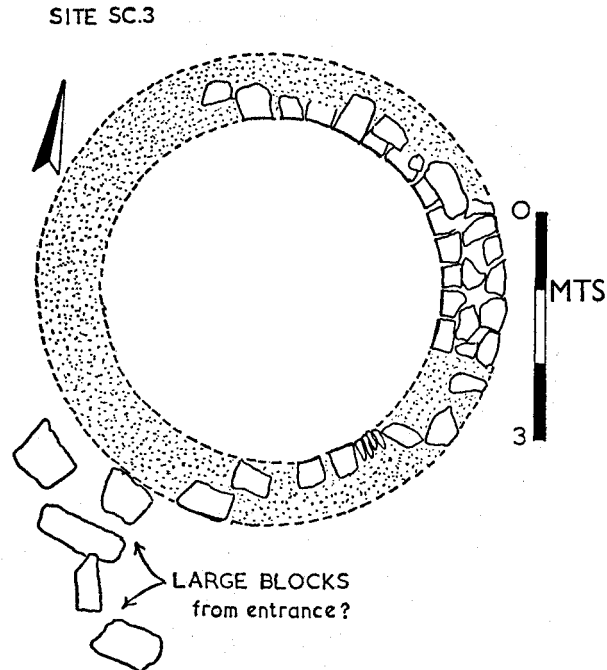

FIG. 3. Early Minoan tholos. Site SC3

destroyed; only the north-east quadrant survives in recognizable form. Here there were four stones of the second course *in situ*, but otherwise only the foundation course survived. It was possible to establish the thickness of the wall as 0.85 m., and the external and internal diameters as 6.2 m. and 4.5 m. The surviving stones in both courses were all small blocks. The only large blocks found on the site were on the south-west side, amongst the robbers' spoil; these included five large blocks of white limestone which it is tempting to see as part of the doorway construction. This need not mean that the door was on the west or south-west side of the tomb, but it was certainly not on the east. It may have been on the south-east, where there were possible traces of an antechamber, but if that were the case then two blocks of stone which we thought were *in situ* would in fact have to be regarded as displaced (see the plan, FIG. 3). Since the tomb was all but destroyed, we carefully cleared the robbers' debris away from the wall in the north-east quadrant to expose the original tomb floor. This we found to be of hard, white earth. Right up against the wall at one point we found a small compact deposit of soil containing bones and sherds which we believe represent a pocket of the original burial deposit overlooked by the robbers.

The twelve sherds we recovered from this tiny deposit are, we believe, significant for dating, since their position strongly suggests that they were amongst the earliest material put into the tomb, right on the floor and right against the foot of the wall, being thus protected from later disturbance. All the sherds were hand-made and some were not at all distinctive (four sherds pale buff with soapy texture, two sherds greenish-buff). Of the remainder, three were of a fine, darkish-grey fabric with medium burnishing. They had no trace of decoration, and the nearest parallels are from the Ayia Kiriaki tholos⁶ where the fabric is associated with some curious prong-handles; this fabric is distinct from EM IIA Fine Grey Ware. There was also the simple rim of a black burnished bowl, and a waist sherd from a round-bottomed buff jug of EM I type. The remaining sherd was of Salame ware (red-slipped and burnished on brownish-buff), dating to EM I. One further sherd is significant for dating the foundation of the tomb, having been found embedded between two of the foundation stones: a vertical suspension lug in coarse black fabric, which we ascribe to the Sub-Neolithic or EM I period.

Support for a foundation date in EM I comes from seven of the sherds found on the surface: six burnished sherds in black and brown fabrics (two from ovoid-section handles or prongs and one with pattern-burnish on the inside face) and a sherd from a red-on-buff suspension vessel of the type found in the EM I level at Lebena.⁷ The only sherd certainly later than EM I was a small piece of EM IIA Fine Grey Ware, but five other sherds of fine, pale grey, burnished fabric might also be early EM II. There was nothing to suggest that this tomb had the long life normally associated with Early Minoan tholoi. The only known parallels for such short-lived usage are the tombs at Salame and Koutsokera, where there is nothing certainly later than EM I.⁸

Small fragments of bone were again found in some quantity, and some of these showed traces of charring, perhaps suggesting fumigation of the tomb at some stage of its usage.

SC4 (Medieval (?), Modern) (FIG. 4; PLATE 6c)

On the saddle between the Ayiofarango Gorge and Kaloi Limenes catchment areas, about 400 m. west of the point at which the Ayia Kiriaki-Kaloi Limenes road crosses the watershed, we discovered two apsidal enclosures. They faced each other across the saddle itself, separated by a distance of c. 13 m. The southern enclosure was the larger, measuring 18.6 m. E.-W. and a maximum of 14.4 m. N.-S., with a single entrance facing north. The enclosure wall survived in its foundation course alone, 0.8 m. wide, and built of blocks of limestone laid back to back with a core of small rubble between. A mass of stone blocks scattered across the saddle suggested that the enclosure wall may once have stood several courses higher. No attempt was made to calculate the volume of building-stone present, but we estimate that there was sufficient to build both enclosure walls up to at least 1 m. in height. Inside the east end of the enclosure was a second less substantial one, consisting of a circle of boulders set into the ground, with an entrance on the west side. It was reminiscent of an enclosure situated 1 km. to the north-east. Both enclosures possessed a rectangular area, marked out by stone slabs set on edge, opposite the entrance.

The northern enclosure measured 15.5 m. E.-W., as far as could be ascertained, and 14 m. N.-S. at its widest point. Its wall was in every respect identical to that of the southern enclosure. The only structure or feature noted inside this enclosure was a little hollow cairn of stones in

⁶ See n. 1.

⁷ S. Alexiou, *ILN* 6 Aug. 1960, fig. 20, bottom row, centre.

⁸ S. Xanthoudides, *The Vaulted Tombs of Mesara* (1924) 73-5, pl. XLa.

the north-eastern corner, with an over-all diameter of about 3 m. Just outside the east end of the enclosure was a second, larger, cairn about 5.2 m. in diameter.

The only sherds recovered were two of Venetian date, with brownish-green glaze and incised decoration beneath the glaze, and one combed sherd, possibly earlier. The site may belong to the Venetian period, but its position and the lack of a dwelling-house suggest that it is to be connected with a small hut about 150 m. to the west, where a few possibly Venetian sherds were greatly outnumbered by modern ones.⁹ As for the purpose of the site, its position seems deliberately chosen to catch as much wind as possible and we tentatively suggest that it was

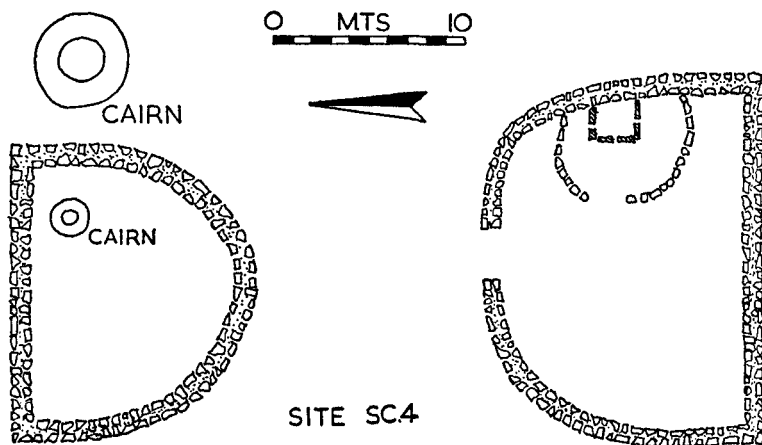

FIG. 4. Industrial site (Sheepfold?). Site SC4

an industrial site of some kind. There was, however, no trace of fire or waste products visible on the surface.

SC5 (M, R) (FIG. 5; PLATE 5c-d)

South of the path from Kaloi Limenes to the mouth of the Ayiofarango Gorge, a small steep-sided and smoothly contoured hill revealed traces of a building complex. Just east of the summit of the hill were house walls, possibly belonging to a single building, whilst on the east-facing slope below two more roughly built walls appeared to form an enclosure attached to the east side of this building. Right on the summit were four walls, each 0.65 m. thick, forming probably one end of a rectangular building, perhaps with a corridor. Just west of this building was a short stretch of a narrower wall, 0.5 m. wide, built on a different alignment, and identical to the walls of the building just east of the summit. The latter were 0.5 m. wide and built of roughly rectangular blocks of limestone; they formed a 15 m. N.-S. stretch of wall with two E.-W. returns, one forming the corner of the building. Just offset from this corner a wall of similar width but rougher build ran down the steep slope for 7.5 m. before turning southwards. This wall was followed for a distance of 21 m. as it curved, partly with the slope of the hill, slightly west of

⁹ This is site E23 of the Ayiofarango survey, see n. 1.

south. The wall was not substantial enough to have supported a building on such a slope, nor was there in its visible length any trace of further returns. We suggest therefore that this wall formed an enclosure of about 95 sq. m. The dimensions of the house to which it was joined may tentatively be estimated at *c.* 19 m. \times 12 m., if we assume that the short fragment of identical and parallel walling on the summit belongs to it. A width of at least 8 m. seems certain, since just inside the line of the north wall, and apparently deliberately placed to back on to it, we

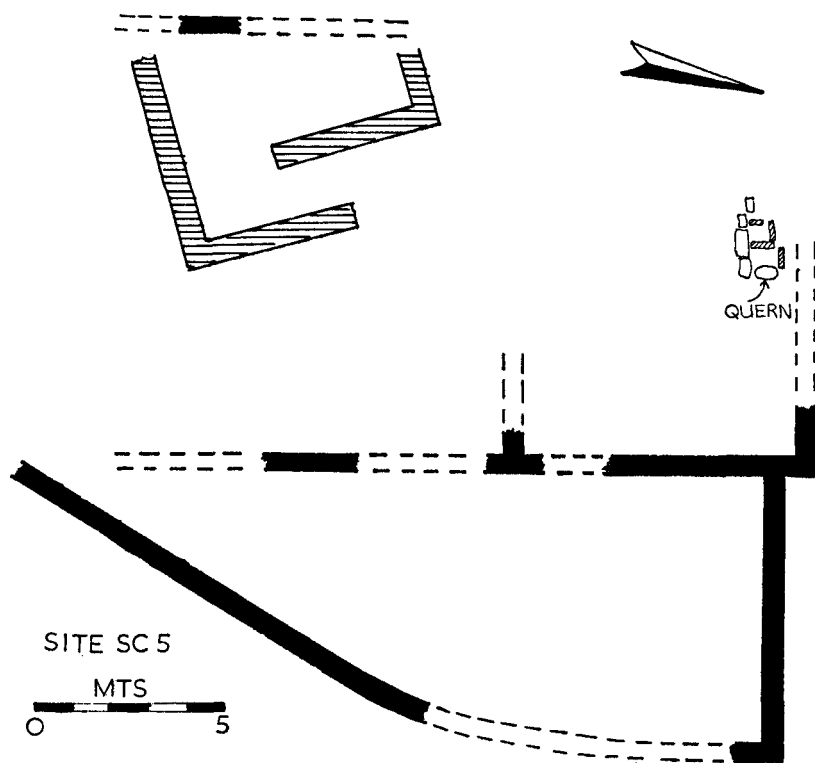

FIG. 5. Minoan farm, and Roman building (hatched). Site SC₅

found a double cist enclosed by stones set on edge. On one side of the cist was a double-sided saddle-quern, and from the soil in the cist came a single sherd of wheel-made buff pottery.

We suggest that there are two quite separate buildings here: that on the summit, of which only the east end has been noted; and that which occupied the area east of the summit together with an enclosure on the eastern slope of the hill. Sherds from the summit area included three distinctive Roman pieces: a buff rim with horizontal groove (FIG. 9, 5/1), a late fourth-century sherd of Cypriote Red Slip ware, and a rim of Late Roman C ware, form 50B (late fourth century). We suggest that these sherds be associated with the thicker walls on the summit of the hill, which may represent a small Roman farmstead or, more probably, a hut. On this particular hilltop, close to the harbour at Lasia and the anchorage at Kaloi Limenes, a small look-out position also seems a possibility.

Of the remaining sherds thirteen were recognizable by their fabric as Minoan, and included a hole-mouthed jar rim.¹⁰ There was also a pinkish-buff sherd with a white surface wash matched exactly amongst the sherds from the EM tholos at site SC11B. We suggest that these sherds relate to the remaining walls on the hill and the double cist. The saddle-quern from the latter certainly indicates a prehistoric rather than Roman date, and although we cannot ascribe a date to the single wheel-made sherd from the earth in the cist, it would not be out of place in an MM context. We therefore suggest that our narrower walls belong to an Early/Middle Minoan building of moderate size, possibly occupied by those who built and used the tholos at SC2 some 350 m. away to the north-west.

SC6 (R) (PLATES 5c-d; 6d; 7c-d)

Kaloi Limenes ('Fair Havens') is the ancient name of the bay which, though far from completely safe, is the safest haven on this stretch of coast.¹¹ Until recently it was known as Kaloi Lim(n)iones, but the classical form has now been revived. It lies four miles east of Cape Lithionon, just over a mile west of Lasaia (SC10, below) and six miles west of Lebena (now Lenda). **The bay is well protected from the sudden northerly winds and offers good anchorage except in the south-easterly winds of winter (cf. Acts 27 : 12: 'the harbour was unsuitable for wintering').** The offshore islands, Nisis Ayios Pavlos and Megalonisi, provide partial protection from the south-west, and there is a deep and safe entrance from the south. Any ancient remains on Nisis Ayios Pavlos have been destroyed since the construction by the SEKA Company in the mid 1960s of a bunkering station; built to provide a convenient refuelling point on the route between the Suez Canal and the Western Mediterranean, it has suffered from the closure of the canal in 1967, but has brought employment, increased population, and electricity to the modern village. Lack of a boat prevented us from visiting Megalonisi, but there are traces of a ruined settlement there, and its history may well be similar to that of Nisis Trafos (SC12, below). A third, smaller islet, Papadoplaka (not visited), lies half a mile to the west; close to it a Hellenistic/Roman amphora has been recovered from the sea.¹²

The harbour is famous only for the visit of St. Paul on his voyage to Rome; hence the modern name of the offshore island, of the mainland promontory to the west, and of the chapel on the hill above (the latter two were, however, called after S. Nicolo in the time of Basilicata, see below). The words used in Acts 27 : 8—'we came to a τόπος called Fair Havens, near which is the πόλις of Lasaia'—make clear that Fair Havens was not a city but a locality, and imply that it was in the territory of Lasaia, which seems certain. The plural form of the name implies

¹⁰ See n. 2. 7 sherds of TF G (coarse brick-red fabric with many brown and white grits, sandy texture), including the hole-mouthed jar rim; 5 of TF D (pale buff with pinkish core, rounded brown grits); 1 of TF C (pale red fabric with white and brown grits).

¹¹ The best description is that by Spratt (*Travels and Researches in Crete* (1865) ii 1-7); in his day Fair Havens was uninhabited except for two coastguards maintained by the monastery *hegoumenos*. The site is not mentioned in nineteenth-century or earlier censuses. At the beginning of this century it had a customs post, but by implication no other habitation; the two main offshore islands were uninhabited: I. Noukhakis, *Kritiki Chorographia* (Athens, 1903) 131-4. It had twenty-two inhabitants, all male, in 1928. The current British Admiralty Chart, No. 1633 (*Harbours and Anchorages on the South Coast of Kriti: Ormos Kalón Liménon* (1966)), is based on the Greek Chart of 1962, No. 107; better for archaeological purposes is the original 1861

edition of the British chart, No. 2724, produced from the 1852 survey. Our map (FIG. 1) draws on these. Contours are taken from Chart 1633, which reproduces alternate contours from the Greek chart. Neither defines the contours, but the hill north-west of Kaloi Limenes (Kaloyero Korfi) is 880 ft. high according to Spratt, 257 m. according to the wartime British G.S.G.S. map. The contours taken by us appear therefore to be at 25 m. intervals.

The article by Bürchner, *RE* x. 2 (1919) 1756-7, should be ignored; it places Kaloi Limenes on the north-east coast of Crete. See also A. Delatte, *Les Portulans grecs* (1947) 77-8. The French research vessel *Calypto* prospected the sea bed off Kaloi Limenes and studied the beaches in 1955: J. J. Blanc, *Annales de l'Institut Océanographique, Monaco*, n.s. xxxiv (1958) 158 ff.

¹² S. Alexiou, *ADelt* xxii (1967) *Chron.* 2, 488.

a number of good anchorages, and it may have referred to the whole coastline as far as Lasaia, including the west harbour there. The *Stadiasmos* (322) mentions only Halai (= Lasaia) and not Kaloi Limenes; somewhat surprisingly it does not mention a port or anchorage there, unlike Matala and Soulia in the following paragraphs.

As one would expect, a small settlement grew up by the west end of the harbour. On the promontory hill by the chapel of Ayios Pavlos a considerable scatter of sherds attests occupation in the Roman and Late Roman periods. The most distinctive sherds were of Late Roman C ware (FIG. 9, 6/1-2), but many of the sherds of coarse wares could be earlier (FIG. 9, 6/3).¹³

There is no visible evidence of earlier occupation. Nor are there any remains of ancient harbour installations in or beside the water except at Lasaia to the east. Since the bay seems to have served principally as a haven for ships in passage, without much import or export trade, the extent of man-made installations may have been very limited.

Though there have been reports of submerged ancient remains at Kaloi Limenes,¹⁴ we could find no trace. Indeed, the indications here and at Lasaia (see below) are of only a very slight net change in relative sea-level between the Graeco-Roman period and the present; this, of course, does not exclude the possibility of, say, earth movements of roughly equal magnitude up and down¹⁵ or a rise in sea-level plus coastal uplift in the intervening period. The theory that major sea-level change was a cause of depopulation of this coast must therefore, on present evidence, be treated with scepticism.

The other cause of depopulation suggested by Faure,¹⁴ piracy and the threat of raids, seems much more likely. The evidence is particularly strong for the sixteenth and seventeenth centuries. Francesco Basilicata has a vivid description of the sinister and suspicious vessels which frequented 'Calous Limionas'.¹⁶ We may reasonably assume a similar situation in earlier, less well-documented periods. There is a tradition that the Arabs landed here or at Matala in A.D. 825.

SC7 (GR) (PLATES 7c-d; 8a-b)

About 200 m. west of Nisos Trafos, and immediately west of the small ravine which marks the western extremity of the ancient city of Lasaia, is situated the necropolis of the city. It falls into two parts. South of the modern road, on a small, sloping shelf above the ravine, we found more than two dozen robbed graves. Some were oblong grave-pits, and others were lined with slabs to form cists. From the many sherds strewn across the area we recovered five distinctive ones which suggest a broad dating for this part of the necropolis: two sherds of early Hellenistic black-glazed (late fourth century B.C.), a black-painted sherd with careless wave pattern (fourth century), another black-painted sherd from a large vessel with a chequered square and broken meander pattern band (Attic, late fifth, probably r.f.), and a broad, flat rim in buff fabric with concentric red-brown bands painted on its upper surface (early Hellenistic). This part of the

¹³ C. Buondelmonti in the early fifteenth century saw 'ruins of large houses' by the harbour, but he may be referring to the warehouses on the shore at Lasaia (*Descrizione insularum archipelagi* [ed. E. Legrand, Paris, 1897] 106, 141).

¹⁴ P. Faure, *BCH* lxxxix (1965) 38.

¹⁵ This may well have happened at Matala: see Blackman, *Proc. Third Cretological Congress, 1971* (1973) 14-21.

¹⁶ *Relazione* 1630: see S. G. Spanakis, *Mnimeia tis Kritikis Istorias*, V (Herakleion, 1969) 17-18. Basilicata adds this to his description of the port in his 'Nota di tutti li

Porti', where he says that it is secure for 10 galleys and 20 or more *navi* except in an Ostro, Sirocco, or Sirocco Levante; he implies a small population in the area. He includes in his 'Nome delle cento Città' the 'city of Bonum Situs and the port now called Calus Limniones' (op. cit. 48); and points out in his notes on the defence of the Kingdom of Candia that the beaches here and at Tsoutsouro are the only ones suitable for an enemy landing between Piryiotissa and Hierapetra (op. cit. 196-7). He appends an evocative plan, dated 1614 (op. cit., pl. 44). On the Arab landing see *Krit. Chron.* xx (1966) 52.

cemetery seems to have been used from late classical to mid-Hellenistic times. It has been heavily looted in recent years.¹⁷

Immediately south of the road there were also remains of a few built chamber tombs with barrel vaults, but these were far more numerous above the road. All of these too had been completely looted, and we found no readily identifiable pottery around them. Internal features, such as the occasional 'bench' and niche, clearly mark them out as mainly Roman, and they presumably were used in the main period of occupation of the city of Lasaiia. We saw many dozens of these tombs, and there must have been many others no longer visible, including those which the building of the modern road completely destroyed.

SC8 (M) (PLATES 7*d*; 8*c-d*)

Almost overlooking the necropolis just described, but perched on a narrow shelf on the very steep hillside some 40 m. above the road, were two small EM tholoi. These are the two ('Chryssotomos I-II') discovered by Branigan in 1965, of which a sketch was published in 1970.¹⁸ They are also the two ('Kaloi Limenes II-III') which Davaras excavated in 1967.¹⁹ In Branigan's catalogue of Mesara-type tholoi, these two tombs appeared as four (Nos. 12-13, 18-19). Tombs 12 and 18 had not been identified because of an apparent difference in the position of the entrance. Davaras had reported that the entrance of tomb 18 ('Kaloi Limenes II') was on the south. When Branigan visited the two tombs at SC8 in 1965 (*before* Davaras's excavation) there appeared to be an entrance on the east, and no sign of one on the south. The 'east entrance' proved on excavation to have been a robbers' trench dug through the wall, and the south entrance had been obscured by the robbers' spoil-heap. Entries 18-19 must therefore be deleted from Branigan's catalogue as published in 1970.

Since the tombs have been excavated and recorded by Dr. Davaras, and will be published by him, we present no details of them here.

SC9 (GR) (FIG. 6; PLATES 7*d*; 9*a*)

Just 50 m. NNW. of the two tholoi at SC8, on a raised knoll, were the walls of a small building. There were traces of several terrace-walls on the slope of the knoll and around its edge, and there were also traces of walls which ran from terrace to terrace, down the slope. The building on the summit of the knoll was only partially visible, and much of the eastern and southern sides had probably been completely destroyed. As far as could be ascertained, the over-all dimensions of the building were 12 m. × 8 m. The walls were built of medium-sized blocks laid two deep to produce a wall width of 0.5 m. for outside walls and 0.4 m. for partition-walls. The entrance appears to have been on the north side, where there is an opening 2 m. wide in the north wall; the only reasonably flat approach to the summit of the knoll is on this side. The centre of the building was probably a small open courtyard, to judge from the complete absence of any traces of walls there and also from the very level nature of the ground

¹⁷ Traces of illicit excavation by the road from Kaloi Limenes to Lasaiia were noticed already in the 1950s: *Krit. Chron.* xiii (1959) 387. Material now in Herakleion Museum which certainly comes from Lasaiia includes 3 funerary stelae (one of Classical date recovered from the sea in the Lasaiia area); two late fifth-century stelae, one inscribed, also probably came from this site; and the Metaxas Collection has acquired several Hellenistic objects originating from here (S. Alexiou, *ADelt* xxiii (1968) *Chron.* 2, 402; C. Davaras, *ibid.* 405 and pl. 368*α*; I. Pini, *Marburger Winckelmann-Programm* (1968) 39 f.; Alexiou, *ADelt* xxiv (1969)

Chron. 2, 412, 415). Road construction in 1964 revealed 3 cist graves 3 m. deep and 1.1 × 0.4 m., which produced Hellenistic figurines and pottery, a silver ring, and a necklace of clay beads (Alexiou, *ADelt* xx (1965) *Chron.* 3, 555).

¹⁸ Branigan, *op. cit.* 150 fig. 33 (cf. Catalogue, p. 170); also illustrated in Branigan, *The Foundations of Palatial Crete* (1970) 163 fig. 38.

¹⁹ Brief report by Davaras in *ADelt* xxiii (1968) *Chron.* 2, 405-6 and pl. 368*β*.

and a scarcity of building debris covering it. On the west side there were clearly two rooms, 2.5 m. \times 2.8 m. and 2.5 m. \times 3.3 m. There were probably rooms on the east side too, but possible traces could be seen of only one, 2.8 m. long and at least 1.5 m. wide. In the extreme south-west corner of the courtyard area a block of limestone, 0.6 m. square and 0.25 m. high, stood as if *in situ*. Just to one side of it was a roughly square, flat block of white limestone, 0.5 m. square and 0.2 m. high, on which was a ring of 12 circular depressions. It is possible that the second block had originally stood on the flat top of the first. The stone with the depressions at once recalled the similar limestone blocks found in the Early Minoan settlement at Fournou Korifi,²⁰

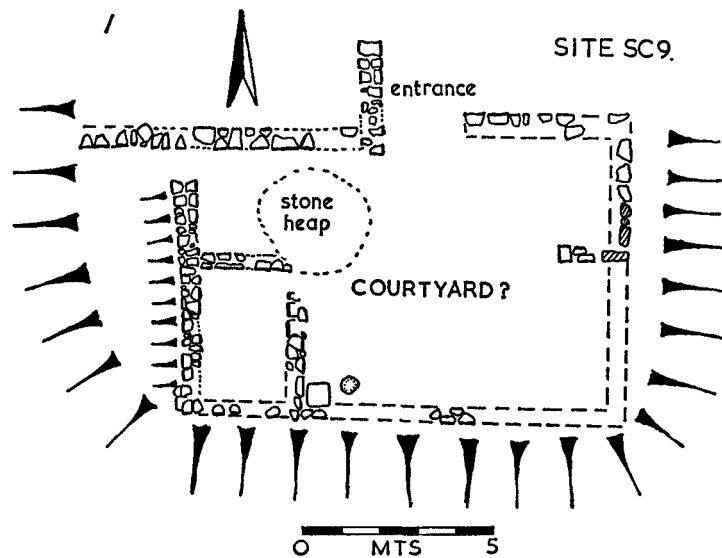

FIG. 6. Hellenistic Roman farmhouse. Site SC9

and there interpreted as 'offering tables'. On our site it is possible that the stone originally came from one of the two near-by EM tholoi. The alternative explanation, that it was not only used but also made by the occupants of the building on the knoll, would raise doubts as to the function of at least this particular 'offering-stone'. It is most unlikely to have been in use as an offering-table in the Hellenistic/Roman period, to which the building on the knoll belongs. A more mundane use is possible, and R. F. Tylecote had suggested to us already that the similar stones from Fournou Korifi were in fact used in pounding and sorting copper ore before roasting. At Chrisostomos, less than 1 km. east of SC9, there is a well-known source of low-grade copper, which might have been utilized in Graeco-Roman times.²¹ On the other hand, there was no trace of fire debris or metallurgical waste on the site, so that there must remain the possibility that the stone was removed from the tholos site in the Graeco-Roman period and used for an unknown purpose in the house on the knoll.

The eight sherds collected from the site included two of *terra sigillata* (second-third century), four of a buff ware of Hellenistic date,²² a Roman rim in buff fabric with horizontal rim groove (FIG. 9, 9/1), and a late Roman corrugated sherd. The building cannot therefore be dated more

²⁰ P. Warren, *Myrtos* (1972) 230-1 pl. 78b-d.

²¹ P. Faure *RA* (1966) I, 52, 58-9, 63; K. Branigan, *Copper and Bronzeworking in Early Bronze Age Crete* (1968) 51.

²² See n. 2. TF N is a hard, buff fabric with reddish core, and heavy fast-wheel marks on the inside surface.

closely than Hellenistic/Roman. It was almost certainly a small farmstead, very similar in plan perhaps to E19 in the Ayiofarango catchment area,²³ and utilizing a small area of good soil on a step just north of the farm building, where no structural remains were found.

SC10 (GR) (FIGS. 7-8; PLATES 7c-d; 9b-d; 10a)

On a small headland opposite Nisis Trafos we examined the remains of the **Graeco-Roman city of Lasaia**.²⁴ The site has been firmly identified since Spratt, who gives a brief description.²⁵ The city, though clearly one of the hundred cities of Crete, was never important, and did not strike coinage. Ancient references to it are few, apart from Acts 27: 8 and the *Stadiasmos* (see above, p. 25); it was never a bishop's see. It may have been dependent on Gortyn in the Hellenistic period. Its name was confused in antiquity (and since) with Lasos, Lis(s)os, and the hypothetical Lissen.²⁶ Faure has recently suggested that the name derived from λάσς (stone), and points to the importance for the city's economy of the stone quarries and deposits of copper and other minerals above Chrisostomos.²⁷ The city's *chora* included the coastline westwards probably as far as Cape Lithinon, and inland as far as the watershed dividing this coast from the Mesara; on the east it bordered the *chora* of Lebena. The inland valley which formed the main centre of our researches belonged to it (and will be discussed in a later report). It may be noted here that a dedication to Asklepios on a clay tablet, rightly listed under Lasaia by Guarducci,²⁸ was in fact found in this valley, at Ayia Kiriaki. Thus the sanctuary indicated by the dedication may not have been in the city proper.

The feature of the site which particularly attracted Spratt's attention was the **breakwater** (FIG. 7; PLATE 9b-c), running out from the point of the promontory towards Nisis Trafos (for which see below, SC12).²⁹ It is a loosely piled bank of large blocks of stone, 90 m. long and swinging westwards for 25 m. at its outer end, leaving a channel 10-15 m. wide between it and the island. The antiquity of the breakwater cannot be proved, but it is likely, for the land site has not been intensively settled since (the site was quite deserted when Onorio Belli visited in 1586, and no settlement here appears in the seventeenth- and nineteenth-century censuses), and the inhabitants of the ancient city are very likely to have wanted to improve the protection of the anchorage by creating a 'Doppelhafen' of standard type. The breakwater may have been altered since construction, especially at its outer end, but there is no way of proving or disproving this. **The channel by the island would have been very convenient for moving ships from one harbour to the other when the wind changed.**

On the west side of the breakwater is a sharply defined shelf of beach rock, just submerged. There is evidence at this site for only slight relative rise in sea-level since antiquity: enough to erode some buildings on the shore, but not enough to submerge the breakwater.³⁰

²³ See n. 1.

²⁴ The ancient testimonia and modern references are conveniently collected by M. Guarducci, *Inscriptiones Creticae* I (1935) 105-6. Add, however, J.-N. Svoronos, *Numismatique de la Crète ancienne* (1890; repr. 1972); and now Sp. Marinatos, *ADelt* xv (1933-5) *Parart.* 78-9; J. D. S. Pendlebury, *The Archaeology of Crete* (1939) 22, 24, 374; P. Faure, loc. cit. (n. 21). Recent looting seems to have been mainly of the necropolis, but Davaras has reported some disturbance of the city site also (cf. n. 17).

²⁵ Op. cit. ii. 7-10.

²⁶ P. Faure, *Krit. Chron.* xiii (1959) 177, 184, 190, 196, 198, 204-5. See also S. G. Spanakis, *Krit. Chron.* xi (1957) 290.

²⁷ Loc. cit. (n. 21). These natural resources may well

have attracted the interest of the more powerful Gortyn. Faure has noted sherds on the peak of Kerkelos, north of Lasaia (375 m.; *BCH* xcvi (1972) 395); this was outside the area of our survey.

²⁸ Op. cit., no. 3.

²⁹ The harbour was illustrated already by Basilicata (op. cit., pl. 43) with the caption 'anchorage of Paleo Molo', a name which confirms the view that the mole is an ancient construction; he (p. 50) located here ancient 'Idabria' (Idauria).

³⁰ Spratt does not comment on possible changes in sea-level here; he wrongly interprets the structures on the shore as part of a sea defence. J. J. Blanc, op. cit. (n. 11) 199, deduced a constant sea-level here since antiquity; cf. D. Hafemann, *AbhAkMainz, math.-nat. Kl.* (1965) 12, 680-1.

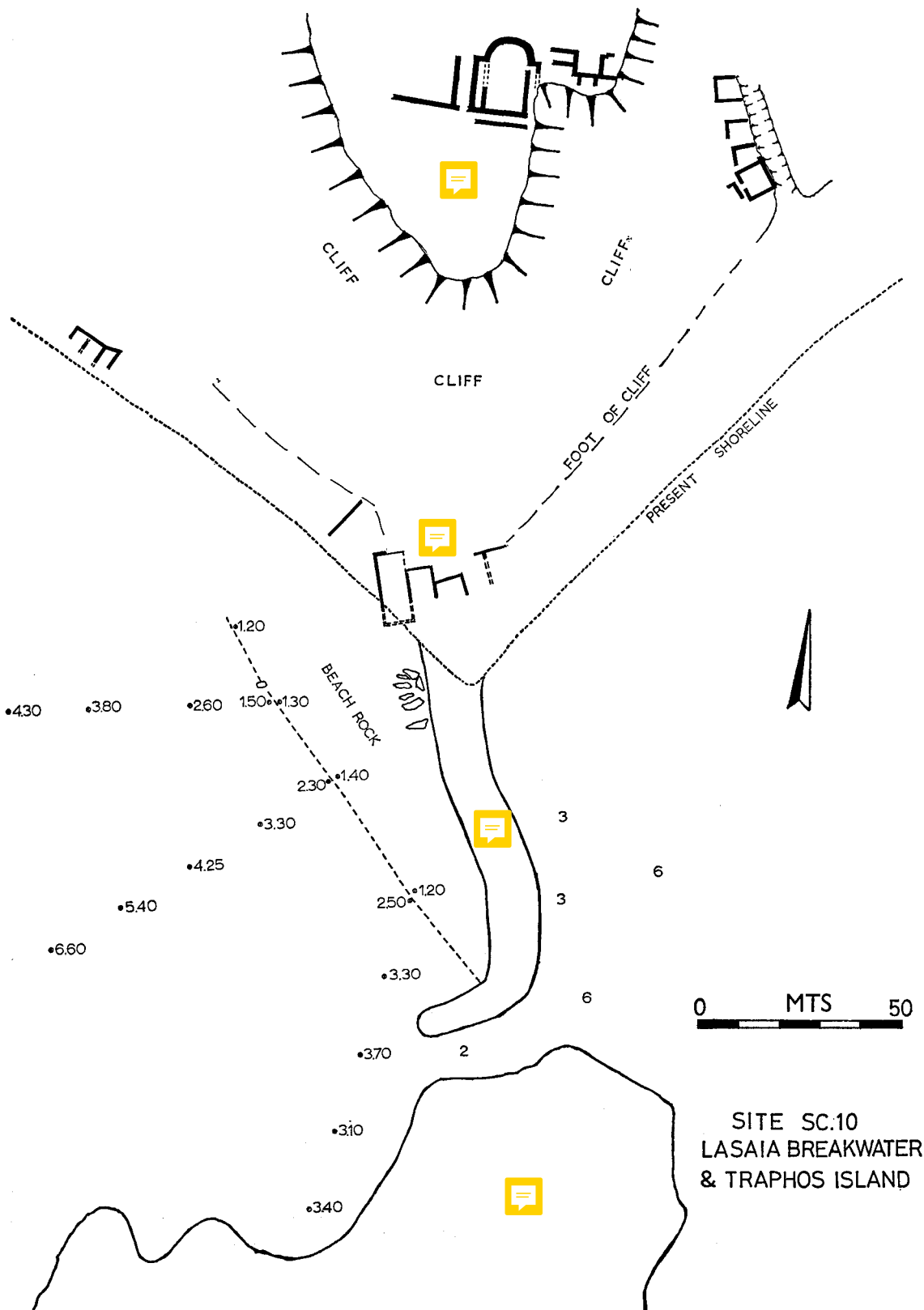

Fig. 7. (Depths in metres)

The city itself was found to spread over four distinct areas. On the shore itself at the foot of the headland were the remains of a number of large buildings, **probably warehouses**, with walls of rubble core faced with small irregular stone blocks, in some cases still standing 3–4 m. high. The outer walls had been partly or completely eroded by the sea, and the inner parts of the buildings had been covered by material fallen from the cliff above (PLATE 9*d*). On top of the headland above was the principal part of the city, occupying an area about 100 m. E.–W. by 150 m. N.–S. This area was studied in more detail than the remaining three and is described below. To the west, the city spread along a 15 m. wide terrace on the cliff side for a further 120 m., with traces of a heavy wall on the edge of the ravine facing the necropolis. There was little spread eastwards from the focus of the city, since a deep ravine separated the headland from the hill-slopes to the east. A few houses had, however, stood on the eastern edge of the ravine. Finally, behind and above the headland to the north was the acropolis, a flat-topped but steep-sided hill on the top of which were traces of a substantial building. It was particularly notable in that the surviving foundations were built entirely of white stone, whereas every other building examined was built of a very colourful mixture of grey, green, brown, purple, and white stone blocks. Excluding the remains on the shore, we estimate the size of Lasaia as approximately 2.5 hectares.

Over most of the headland, the walls of houses could be easily traced and we made a plan of these remains (FIG. 8). The plan is the work of two of the team in a single day and we do not claim that it is highly accurate; it does, however, give a fair representation of the disposition and the nature of the buildings found on the main headland. The southernmost building which we found proved, when planned, to have a very distinctive form—with a large apse, a nave, and two aisles. It is difficult to imagine that this building was anything but a church. Traces of a second apsidal structure lay 40 m. west of it, but insufficient remained to show the original form of this building. A substantial area north of the ‘church’ contained the remains of several buildings, presumably the houses of merchants, to judge from their apparent size. On the western edge of this group was another distinctive building, approached from the south by a flight of six steps (PLATE 10*a*). The entrance was flanked by stone bases, perhaps for columns, and led into a single oblong room, 9 m. long and 5 m. wide. The building can be almost certainly identified as a temple.

Almost in the centre of the headland stood another notable building, the extent of which is uncertain. It appeared to have an enclosed courtyard, 30 m. long and 10 m. wide, flanked on the north by a long narrow room or possibly a wide corridor, and on the south by a wide corridor which gave access to a suite of rooms. In the southern corridor, against the wall enclosing the courtyard, we found two substantial bases, possibly for columns but possibly for statues. In our brief examination of the site we found two fragments of white marble statuary, both about 20 m. north of the courtyard described. Other buildings were situated on the northern part of the headland, but since hill wash from the acropolis slopes above covered large areas of them, their size and form could not be determined.

At the north-east corner of the headland stood a large, lined cistern, which was the main source of water for the town. An aqueduct brought water to the cistern across the hill-slopes from the east; we traced it for a distance of about 600 m. to its source in a still flowing, and very precious, spring. The aqueduct consisted of a plastered channel, 10 cm. wide and 5 cm. deep, carried on a mortared masonry wall.

From the summit of the acropolis we recovered 20 sherds, only one of which was Roman. The remainder included late fourth/mid third-century B.C. bowl bases (FIG. 9, IOACR/1–2), black-glazed, and rims of a jar (FIG. 9, IOACR/4) and cup. There was also a late Hellenistic black-

glazed base and a third-century 'fish plate' rim (FIG. 9, 10ACR/3). The acropolis, therefore, seems to have been used during Hellenistic times only, and its period of usage broadly coincides with the period of the cist graves in the cemetery to the west. A few equally early sherds were found on the headland—6 late fourth/third-century black-glazed, 2 late Hellenistic bases and 1 rim,

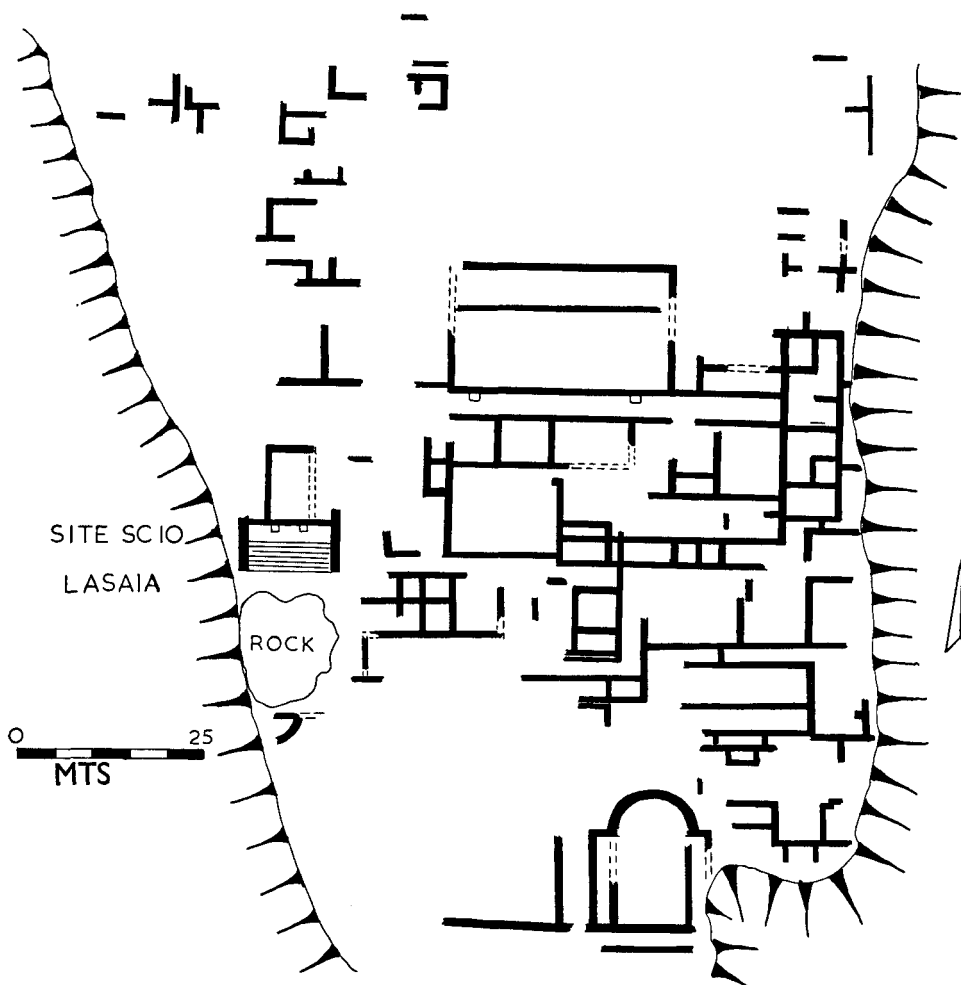

FIG. 8

and a fragment of a late Hellenistic lamp. The latest datable sherds of this group are of the third/second century B.C., but there may have been continuity of occupation into the Roman period. The latter is represented by two principal groups of material. The earlier group includes 8 sherds of first-century A.D. Arretine, and 1 sherd of contemporary Cypriote *terra sigillata*. The later group comprises mainly African Red Slip Ware and Late Roman C bowls and dishes of late fifth/early seventh-century date (FIG. 9, 10/1-5), and contemporary sherds of corrugated ware. Late Roman C ware was certainly prolific on the site, which suggests that the site was flourishing in the later Roman period. There is little, however, with which one can confidently fill the period from the first to the late fifth century. One bowl rim, paralleled in fabric as well

as form at Knossos, has been noted by Dr. Hayes and dated to the second century A.D., but nothing else of distinctively second–fourth-century date was identified. It seems unlikely, however, that the site was deserted in that period, and occupied intensively both before and after it. The hiatus is probably more apparent than real, the result of our comparative ignorance

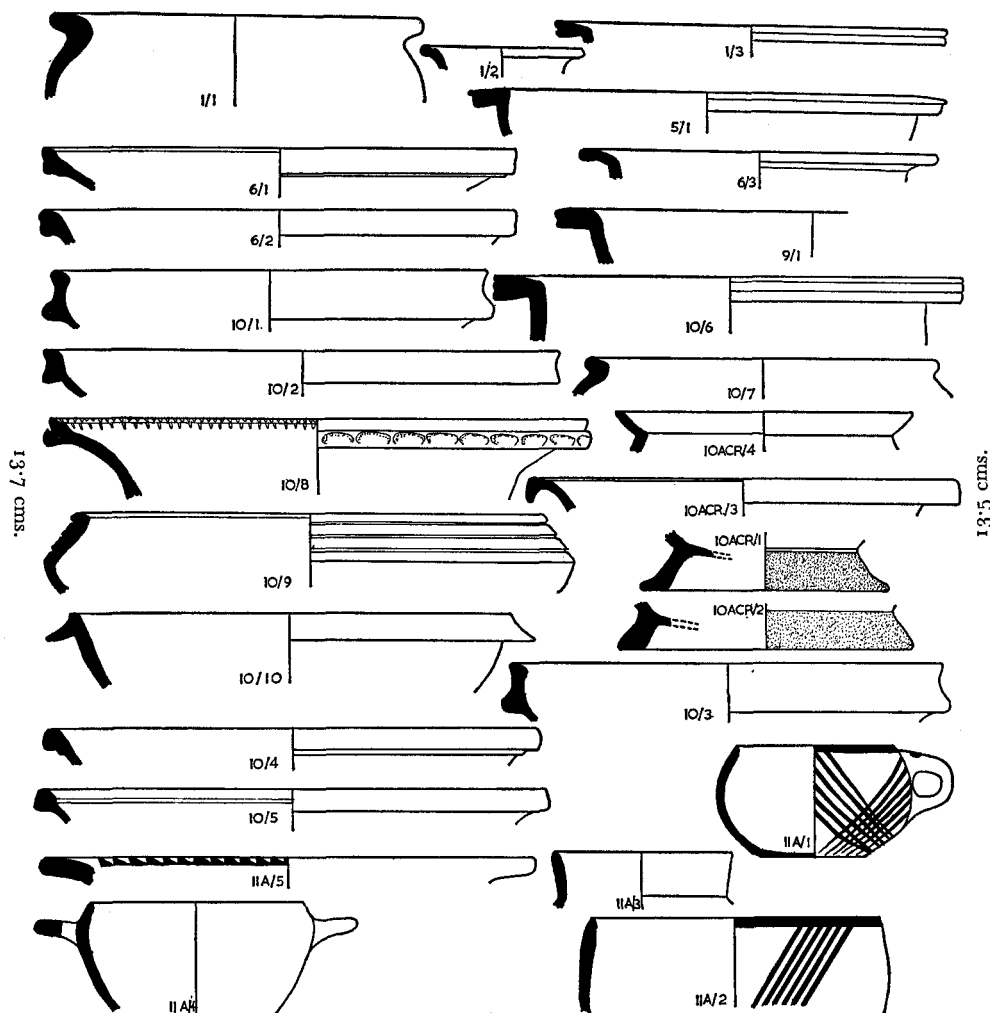

FIG. 9. Pottery from sites surveyed (10 Acr = Lasaia Acropolis)

of Roman coarse wares of the second–fourth centuries A.D. Sherds of cooking-pot and plain buff fabrics may well belong to this period (FIG. 9, 10/6–10).

SC11 (M) (FIGS. 10–11; PLATE 10*b–d*)

On a wide shelf above and NNE. of the ruined church of Chrisostomos, we found two tholos tombs, standing about 175 m. apart. The area between them yielded a number of sherds, including 5 of a creamish/pale buff fabric found by us elsewhere in an EM context,³¹ two brownish-black washed MM sherds, and two sherds of fast-wheel pottery with a rich brown

³¹ TF D. See n. 10.

wash on the inside surface. These may indicate a settlement site, although no certain trace of walls was found between the tombs.

The northern of the two tombs, 11A, was partially overlain by an abandoned modern hut. Its southern half was largely destroyed, and the northern half had suffered damage too (PLATE 10c). Sufficient remained to show that the tomb originally had an interior diameter of 5.25 m.; its roughly coursed wall was a little over 1 m. wide, and survived, with a slight overhang, to a maximum height of 1 m. The doorway must have been on the south or east side, since there was no trace of it in the surviving part of the wall.

The tholos had been thoroughly robbed and the spoil-heaps had been sieved, but a group

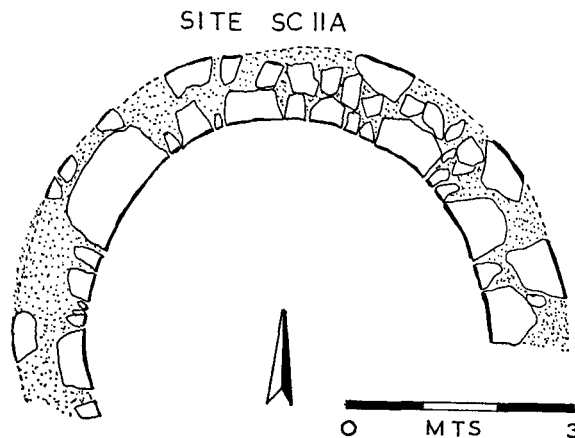

FIG. 10. Early Minoan tholos. Site SC11A

of readily identifiable sherds was collected. Apart from examples of two fabrics found by us elsewhere in an EM context,³² there was a considerable amount of Ayios Onouphrios ware, mostly round-bottomed and handled cups of the 'Koumasa' type, probably belonging to EM IIA (FIG. 9, 11A/1-2). The earliest sherds were a short, straight neck of an EM I spherical jar (FIG. 9, 11A/3), and a suspension-lug from an EM I Ayios Onouphrios vessel of the type well represented in the EM I levels of the Lebena tombs. The latter was found actually built into the wall, so that the tomb must have been constructed *during* EM I or later. Other distinctive sherds included the profile of a Vasiliki ware bowl (EM II; FIG. 9, 11A/4) and two sherds from a broad plate with a saw-tooth pattern on the rim and a chequerboard pattern on the outer face (EM II; FIG. 9, 11A/5). The latest sherd was a single fast-wheel sherd of MM black-washed pottery. We also recovered 2 limpet and 2 mussel shells from the site.

Tomb 11B was also almost entirely destroyed on its southern side, and proved to be almost identical in size to 11A. Its interior diameter was 5.2 m. and its wall was 0.9-1 m. wide, built of the same rough blocks used for 11A. Nowhere did the wall survive to more than 0.7 m. in height, but the east entrance was fortunately preserved (PLATE 10d). This was of trilithon type, although the lintel was not found *in situ*. The entrance was 0.7 m. wide and 0.7 m. high, flanked by two jambs 1.1 m. and 1.2 m. long. Just south of the entrance we found a very large displaced slab, 1.2 × 0.75 × 0.3 m., which was probably the original lintel. Outside the doorway there

³² TF D and TF G. See n. 10.

were stones showing through the soil which suggested the presence of an antechamber, whilst four stones set in line, running almost parallel with the tomb wall and 0.75 m. east of it, suggested the possibility of other structural features on the north-east side.

Thorough looting had left very little material for us to recover. A total of 20 sherds was found, mostly of hand-made wares with no distinctive features. There was one sherd of red-burnished 'Salame' ware, one of EM IIA Fine Grey Ware, and two of a creamish/pale buff EM fabric.³³ These were sufficient to confirm an EM date for the tomb, and suggest use in EM I-II at least.

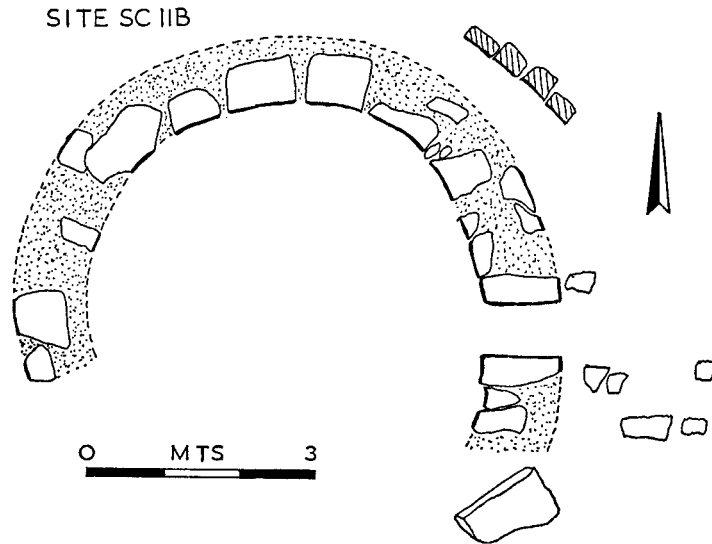

FIG. 11. Early Minoan tholos. Site SC11B.

SC 12 (Late Roman (?), Medieval, Modern) (PLATE 7c; 9b-c)

The island Nisis Trafos, lying off the headland occupied by Lasaia, and named after the breakwater, proved to be densely occupied by small, almost cell-like stone huts which were still well preserved. We had insufficient time to make a plan of the remains, which included narrow streets running between the huts, but a small collection of sherds was made showing a very clear predominance of Second Byzantine or Venetian material. The island was almost certainly used as a refuge, as Mr. Hood has demonstrated for offshore islands around the coast of mainland Greece.³⁴ Some usage in Graeco-Roman times seems likely, however, and a single sherd of fifth-century A.D. corrugated ware was identified by Dr. Hayes.

DISCUSSION

The sites discovered in this brief survey fall into two main periods of antiquity, the Early Bronze Age and the Hellenistic and Roman era. The farmstead at SC5 may have seen some occupation in Middle Minoan times, but the six tholoi examined produced a single MM sherd between them and must have been effectively out of use by MM I. From this period (about

³³ TF D. See n. 10.

³⁴ M. S. F. Hood, 'Isles of Refuge in the Early Byzantine Period', *BSA* lxx (1970) 37-45. These, however, were for refuge from the Slavs, which cannot be the case in

Crete. The island was used as a refuge in the nineteenth century (Spratt, *op. cit.* II 7), and the visible buildings may date from that period; the island was uninhabited at the end of that century: Noukhakis, *loc. cit.* (n. 11).

2000 B.C.) until the late fifth century B.C. there are no traces of occupation along this strip of coast. Renewed settlement first focuses on Lasaia and then spreads westward to Kaloi Limenes and the area just west of it. It appears to reach its peak in the late Roman period (fifth and sixth centuries) before rapidly declining and disappearing. Later occupation is attested only on Trafos Island, which we believe is a medieval and modern refuge site, and at SC₄, a possible industrial site almost within the Ayiofarango valley and probably related to a small medieval or later hut found 150 m. away.

These same two main periods of occupation separated by a long period of abandonment have been noted in the settlements in the Ayiofarango catchment area,³⁵ and it is thought that the Middle Minoan abandonment of the valley may have resulted from a gradual drift towards the new palatial centre at Phaistos. The second period of abandonment, from the mid seventh century to the Second Byzantine or even the Venetian period, has no certain cause, although the Arab conquest occupies part of it. The scarcity of medieval sites on the coast suggests that pirates may have been active in this period. Medieval occupation is attested on a small scale in the safer confines of the Ayiofarango valley, and here the monastery of Odiyitria was flourishing by the mid sixteenth century; at this time, or possibly earlier, the monastery of Ayios Antonios, founded at the mouth of the Ayiofarango, was moved inland to Apezanes, because of the threat from pirates, whose activity in the sixteenth and seventeenth centuries is well attested.³⁶

The nature of the Minoan occupation on the coast is not certain from our discoveries. On the hill at SC₅ we appear to have a small farmstead, but the two nearest tholoi (SC₂ and 3) suggest that a larger settlement may remain to be found in the vicinity. The most likely situation is on the slope occupied by SC₁, where two MM sherds were found, possibly associated with the occupation of the SC₅ farmstead. An earlier Minoan occupation here is quite possible, although no EM sherds were noted here by us. No trace of a related settlement was found by the SC₈ tholoi, but there were suggestions of one, in the form of a sherd spread, in the area between the tholoi at SC₁₁. Further east, the tombs excavated by Alexiou at Lebena were found to be sited alongside a contemporary settlement, and the same is likely to be true of SC₁₁ and SC₂ and 3. Lebena, like the three tholos cemeteries in our survey area, has a beach suitable for beaching the small boats of the EM period, and it seems certain that the population represented by the six tholoi in our survey area fished out of the harbours at Kaloi Limenes and Lasaia.

Since three of our tholoi were almost completely destroyed, and two are to be described and discussed by Dr. Davaras, comment on them may be kept to a minimum. All of them were EM I foundations, to judge from the sherds around them, and the importance of the tombs at SC₈ for the problem of the origins of the Mesara tholoi has been discussed elsewhere.³⁷ The larger tomb here was well preserved to a height of more than 2 m. and its method of construction, with small stones, did not suggest a full stone vault. The tholos at SC₂, on the other hand, also preserved to over 2 m. in height, revealed the use of large slabs of stone in its upper parts and could conceivably have been fully vaulted in stone. None of the tombs was associated with a complex of outer rooms, although there may have been an antechamber at SC₁₁A.

Of the Graeco-Roman sites little can be said, except for Lasaia and the farmstead at SC₉. **The character of Lasaia is demonstrated by the breakwater and the big warehouses on the shore, which coupled with its location make it clear that it served as a harbour town.** Its other source of (limited) prosperity was the mineral deposits and stone quarries just to the east at Chrisostomos. The remains on the headland include several which appear to belong to public

³⁵ See n. 1.

³⁶ These sites will be discussed in a further article. See n. 1.

³⁷ Branigan, *op. cit.* (n. 3) 149-50.

buildings, of which the most notable perhaps is the basilican church. The probable temple to the north-west may have been preceded by another which stood on the acropolis behind the headland; the all-white stone walls here suggest a building for which careful preparations were made. Otherwise the city would have presented a colourful spectacle with its walls built of multicoloured stone. One can do little more than guess at the population of the city in its heyday, but a Roman city of 2.5 hectares might be expected to house four to five hundred people.

The farmstead which overlooks Lasaia (SC9) is of interest largely because so little is known of Roman farmhouses in Crete. Pendlebury's list of Roman sites included many that are probably those of farms, but apart from a 'rectangular building' at Vagionia no details of them were given.³⁸ The building near Lasaia appears to have had two ranges of rooms, one on either side of a small central yard. It is very similar to another Roman farmhouse we discovered near Gavaliana in the Ayiofarango valley, and two further Roman farmhouses in that valley are similar in size, though they apparently lack the central yard of the first two buildings.³⁹ A similar building may have stood on the slopes at SC1, and evidence from the survey of the coast combined with that of the Ayiofarango valley suggests that these small farmsteads were by no means uncommon in the Asterousia mountains during the Roman period. Whereas the Minoan tholoi have been discussed and examined at length, both harbour towns and farms in Roman Crete remain to be given the attention which they thoroughly deserve.

ACKNOWLEDGEMENTS

The other members of the team were M. Fischer and D. E. Waite. We are grateful also to Dr. S. Alexiou for his help, advice, and encouragement; to the officers of the British School for their support; and the Vardinoyannis family for their hospitality in Kaloï Limenes. We also benefited from discussions with Mr. Sinclair Hood, Mr. Nicolas Coldstream, Dr. John Hayes, Dr. Alan Johnston, and Dr. Costis Davaras. The sherds recovered by us have been placed in the Stratigraphical Museum at Knossos.

D. J. BLACKMAN
K. BRANIGAN

³⁸ *The Archaeology of Crete* (1939) 369-76; Vagionia (south-east of Gortyn) 375.

³⁹ E19; E5 and W2A. See n. 1.



(a)

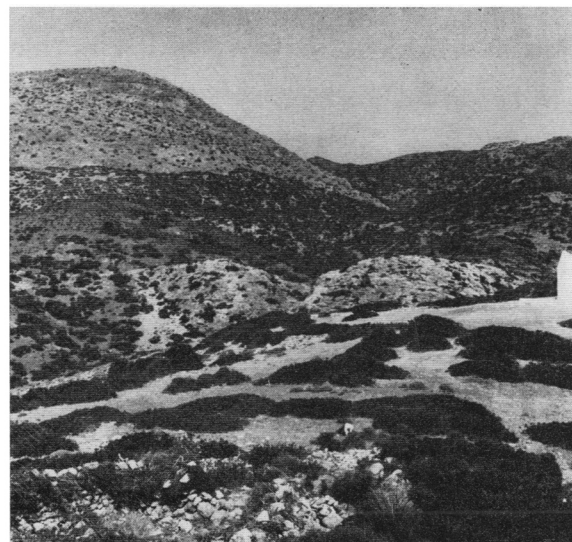

(c)

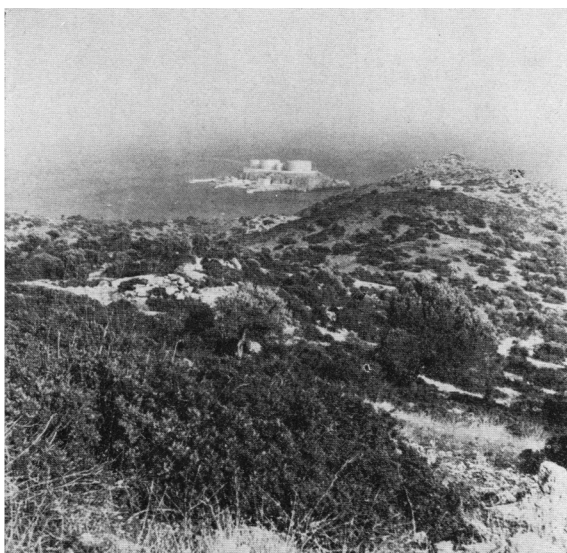

(d)



(b)

AN ARCHAEOLOGICAL SURVEY ON THE SOUTH COAST OF CRETE

(a) The south coast, looking east from Kaloi Limenes. Lasaia and Trafos Island visible in the middle distance; (b) The south face of Kaloyero Korfi, north-west of Kaloi Limenes; below the raised beach line, site SC1; (c) View north-west from the chapel of Ayios Pavlos (site SC6). On the left, middle distance, site SC5; beyond and below the raised beach line, SC2; on the right, middle distance, SC3; (d) View south-east from above SC2 (visible on left); the rounded hill, centre-right, is SC5; beyond is the chapel of Ayios Pavlos.



(a)



(d)



(c)



(b)

AN ARCHAEOLOGICAL SURVEY ON THE SOUTH COAST OF CRETE

(a) SC2: tomb entrance (interior) from the north-west; (b) SC2: tomb interior, looking east; (c) SC4: from the north-west; (d) Kalo Limenes from the north, with Megalonisi visible beyond

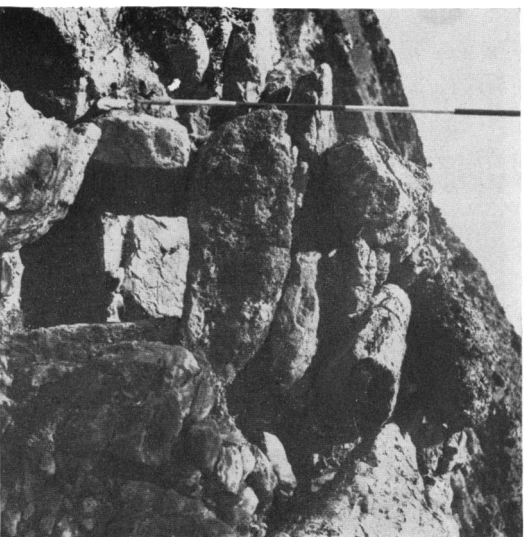

(a)

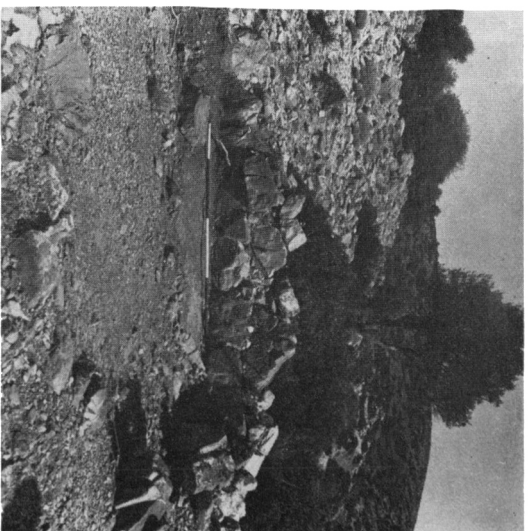

(b)



(c)

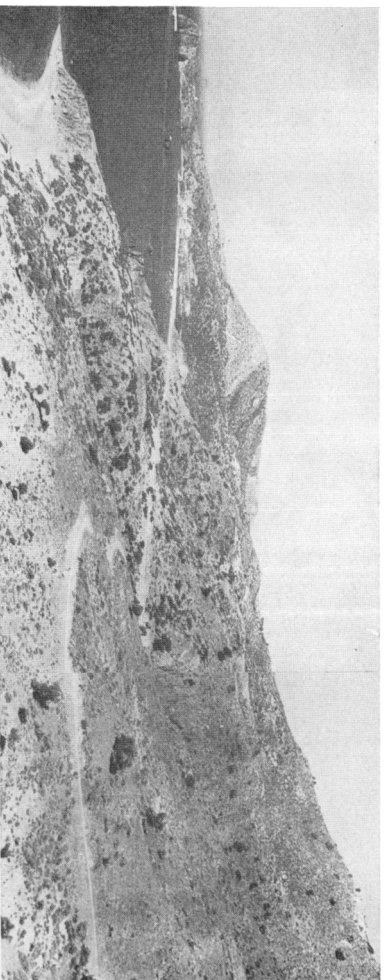

(d)

AN ARCHAEOLOGICAL SURVEY ON THE SOUTH COAST OF CRETE

(a) SC2: tomb entrance (exterior) from the east; (b) SC3: tomb interior from the south-west; (c) Lasala and Kaloi Limenes from the east (site SC11); Tralos Island and the breakwater, centre-left; (d) Lasala, Kaloi Limenes, and sites SC7-9 from the east. Lasala beyond the first ravine; SC7 beyond the second; SC9 on the terrace above the road, with SC8 just below



(a)



(b)



(c)



(d)

AN ARCHAEOLOGICAL SURVEY ON THE SOUTH COAST OF CRETE

(a) Lasaia necropolis (SC7), a built cist-grave; (b) Lasaia necropolis, a built chamber tomb of Roman date; (c) Tholos tombs at Lasaia (SC8), on slope centre-right from north-east; (d) Tholos tomb (No. 12) at Lasaia: inner side, set into slope

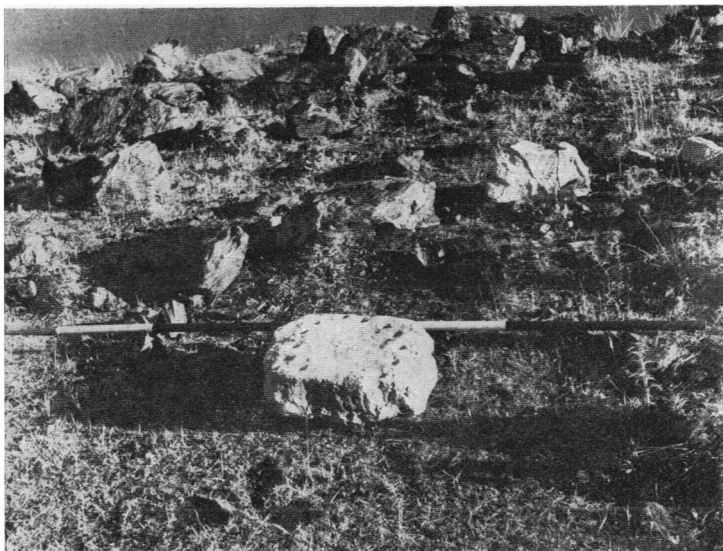

(a)

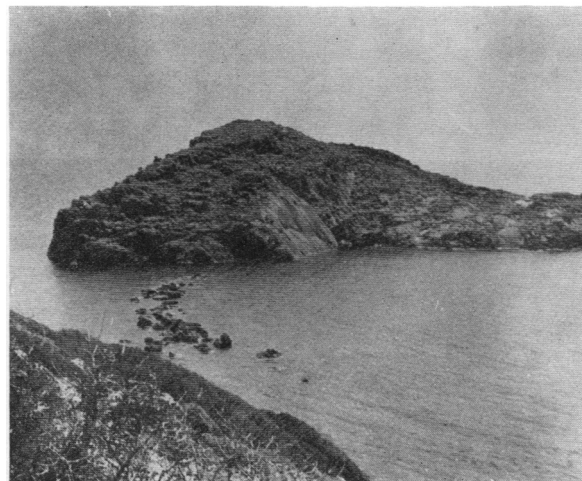

(b)



(c)



(d)

AN ARCHAEOLOGICAL SURVEY ON THE SOUTH COAST OF CRETE

(a) Hellenistic/Roman farmhouse (SC9): block with 12 depressions; (b) Lasaia breakwater and Trafos Island from the north; house walls can be distinguished on the island; (c) Lasaia breakwater and Trafos Island from the west; (d) Lasaia warehouses on the shore



(a)



(b)



(c)



(d)

AN ARCHAEOLOGICAL SURVEY ON THE SOUTH COAST OF CRETE

(a) Lasaia: steps of the 'temple'; (b) The shelf bearing tholos tombs (SC 11A and B), from the south-west (Lasaia); (c) SC 11A, from the south-east; (d) SC 11B: tomb entrance (exterior) from the east