

See discussions, stats, and author profiles for this publication at: <https://www.researchgate.net/publication/289239067>

# Proposal of the Global Initiative: EarlyWatercraft – A global perspective of invention and development

Book · January 2016

CITATIONS

0

READS

6,788

1 author:



Miran Erič

Institute for the Protection of Cultural Heritage of Slovenia

44 PUBLICATIONS 87 CITATIONS

SEE PROFILE

Some of the authors of this publication are also working on these related projects:



Visual language [View project](#)



Underwater documentation methodology [View project](#)

# GLOBAL INITIATIVE:

## Early Watercraft – A global perspective of invention and development

### Proposal of the Initiative

(Edited by: *Ronald Bockius and Miran Erič with Ambassadors*)

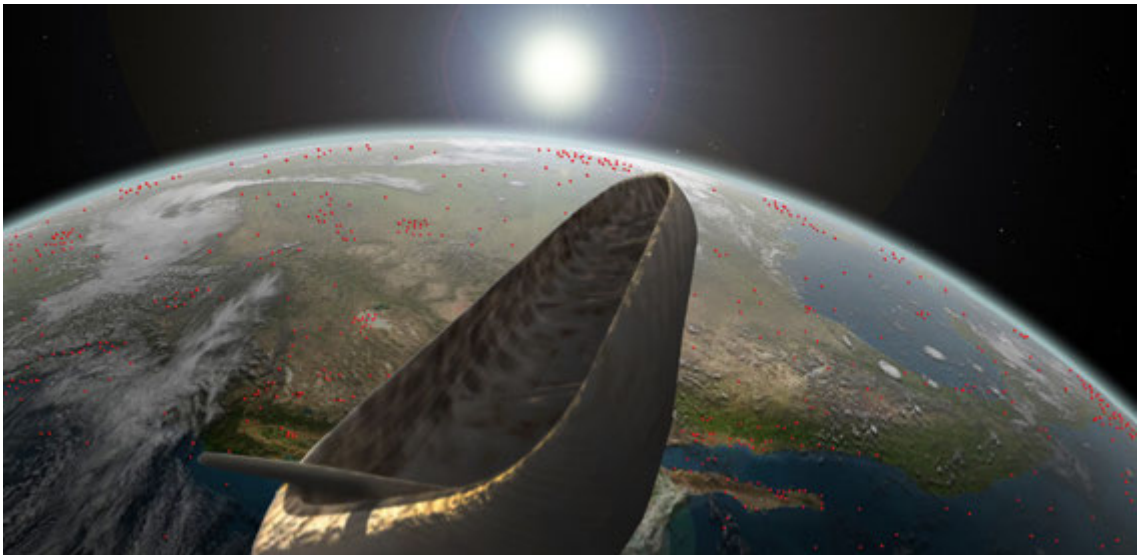

Vrhnika, Slovenia  
19<sup>th</sup> - 23<sup>rd</sup> of April 2015

## GLOBAL INITIATIVE:

### Early Watercraft – A global perspective of invention and development



*Figure 1:*  
**Symbolic meaning of the official EWA logotype**

**Idria lace**

*represent water net and connecting of all nation around the world*

**Inner green round drawing**

*representing our planet Earth*

**Outer red round drawing**

*represent the oldest and most important human invention*

**Early Watercraft Initiative**

*is the short name of the global initiative "Early Watercraft - a global perspective of invention and development"*

**Red colour of the name**

*is the symbolic meaning of the oldest clay red pigment iron oxide used by humankind*

**100 Individual Ambassadors of Initiative:****22 Institutional Ambassadors of Initiative:****49 Participated Countries (Alphabetically):**

Alaska (USA), Australian Capital Territory (AUT), Bolgarija, Bolivia, Bosna i Hercegovina, Catalunya (Espanya), Canada, Colombia, Česko, Črna Gora, Denmark, Deutschland, Eesti, Egypt, Éire, España, France, 한국의 나라 이름 (Han-Guk, Korea), 香港 (Hong Kong, China), Hrvatska, Italia, Korea, Latvija, Libnān, Lietuva, Maine (USA), Magyarország, Makedonija, Maṣr (Egypt), New South Wales (AUT), 日本 (Nippon), Norvége, Ontario (CND), Österreich, Pilipinas, Polska, Portuguese, Prathet Thai, Россия (Russia), 西省 (Shaan'xi, China), Slovenija, Srbija, Srī Lamkā, Suomi, Switzerland, Україна (Ukraina), United Kingdom, Victoria (AUT), Việt Nam

**Béat Arnold, Doyen**

European pioneer of systematic scientific research of early watercraft, Neuchâtel, Switzerland; *beat.arnold47@gmail.com*

**Ronald Bockius**

Museum für Schifffahrt des Römisch - Germanisches Zentralmuseum, Mainz, Deutschland; *bockius@rgzm.de*

**Miran Erič**

Zavod za varstvo kulturne dediščine Slovenije, Ljubljana, Slovenija; *miran.eric@guest.arnes.si*

**Michael Klein**

7reasons Medien GmbH. Wien, Österreich; *michael.klein@7reasons.at*

**Otto Cichocki**

VIAS - Interdisziplinäre Forschungsplattform Archäologie, Universität Wien, Wien, Österreich; *otto.cichocki@univie.ac.at*

**Andrej Gaspari**

Oddelek za arheologijo Filozofske fakultete, Univerza v Ljubljani, Ljubljana, Slovenija; *andrej.gaspari@gmail.com*

**Niall Gregory**

Archaeology & Safety, Charter of European Rural Communities, Cashel, Ireland; *nialltgregory@gmail.com*

**Waldemar Ossowski**

Narodowe Muzeum Morskie w Gdańsku, Gdańsk, Polska; *w.ossowski@nmm.pl*

**Lars Kröger**

Archäologie des Mittelalters und der Neuzeit, Otto Friedrich Universität Bamberg, Bamberg, Deutschland; *Kroeger@dsm.museum*

**Dragan Živadinov**

Kulturno središče evropskih vesoljskih tehnologij / Cultural Centre of European Space Technologies, Vitanje, Slovenija; *info@delak.eu*

**Cynthia Dunning Thierstein**

ICOMOS/ICAHM; ArchaeoConcept Sàrl,  
Biel/Bienne, Switzerland;  
*cynthia.dunning@archaeoconcept.com*

**Franc Solina**

Laboratorij za računalniški vid Fakultete za  
računalništvo in informatiko, Univerza v  
Ljubljani, Slovenija; *franc.solina@fri.uni-lj.si*

**Kaja Antlejš**

Lecturer in Industrial Design at Deakin  
University, Waurn Ponds, Victoria, Australia;  
*kantlejš@gmail.com*

**David Payne**

Australian National Maritime Museum,  
Sydney, Australia; *dpayne@anmm.gov.au*

**David John Gregory**

Miljøarkæologi og Materialeforskning,  
Nationalmuseet er Danmarks, Kongens  
Lyngby, Denmark;  
*david.john.gregory@natmus.dk*

**Aivar Ruukel**

Soomaa.com, OÜ Viis aastaaega (Five  
Seasons), Eesti; *aivar@soomaa.com*

**Karl Brady**

Underwater Archaeology Unit, Department of  
Arts, Heritage & the Gaeltacht, Dublin, Ireland;  
*karl.brady@ahg.gov.ie*

**Saša Koren**

Student; Oddelek za arheologijo FF, Univerza v  
Ljubljani, Slovenija; *v\_olj\_a@hotmail.com*

**Philippe Bonnin**

GRAS - Groupment de recherches  
archéologiques subaquatiques, Brunoy, France;  
*archsubgras@free.fr*

**Philippe Guillonnet**

GRAS - Groupment de recherches  
archéologiques subaquatiques / Médiateur du  
patrimoine indépendant Préhistoire  
interactive, Rennes, France;  
*ph.guillonnet.cpie@wanadoo.fr*

**Sara Ćorković**

Student; Oddelek za arheologijo FF, Univerza v  
Ljubljani, Slovenija; *sara.corkovic@gmail.com*

**Matej Školc**

Student; Oddelek za arheologijo in dediščino  
FHŠ, Univerza na Primorskem, Koper,  
Slovenija; *matejskolc@gmail.com*

**Atle Ove Martinussen**

Bunad og folkedraktrådet The National  
Council of folk costumes in Norway,  
Hordaland, Norvége;  
*atleovemartinussen@muho.no*

**Gary Ball**

History Matters Group - Ancient boat project,  
Wales, United Kingdom;  
*historymattersonline@gmail.com*

**Trevor Northage**

Master Mariner and ship's Captain at Odfjell,  
Marine Superintendent, Odfjell, Lough Corrib,  
Ireland; *trevor@anglingcharts.com*

**Jason Rogers**

Northern Land Use Research Alaska, LLC.,  
Anchorage, Alaska; *alaskamaritima@gmail.com*

**Evguenia Anichtchenko**

Anchorage Museum at Rasmuson Center,  
Anchorage, Alaska; *anichenkojenya@gmail.com*

**Anton Simonič**

Ministry of Education, Ljubljana, Slovenija;  
*anton.simonic@gov.si*

**Ljoba Jenče**

Heritage House, Cerknica, Slovenija;  
ljoba.jence@guest.arnes.si

**Cyril Dworsky**

Kuratorium Pfahlbauten UNESCO-World  
Heritage Prehistoric Pile Dwellings around the  
Alps, National Management Austria, Wien,  
Austria; dworsky@palafittes.at

**Bogdan Kladnik**

Guardians of Universe, Ljubljana, Slovenija;  
bogdan@kladnik.net

**Gerald Egger**

UNESCO Pfalbauten, Seewalchen, Österreich;  
gerald.egger@pfahlbau.at

**Abhirada Pook Komoot**

University of Western Australia, Bangkok,  
Thailand; abhirada.k@gmail.com

**Mi Young CHA 차 미 영**

National Research Institute of Maritime  
Cultural Heritage, Korea; cmy040301@nate.com

**Roh Kyeong-jung 노 경 정**

National Research Institute of Maritime  
Cultural Heritage, Korea; rohgabba@korea.kr

**Kim Do-Hyun 김 도 현**

Pukyong National University; ICOMOS Korea,  
Korea; koceco1@hanmail.net

**Lucy Semaan**

Department of Archaeology and Museology,  
University of Balamand, Lebanon;  
Lucy.Semaan@balamand.edu.lb

**Jun Kimura ジュン キムラ**

Department of Maritime Civilisations, School of  
Marine Science and Technology, Tokai  
University, Japan; junkimura@tsc.u-tokai.ac.jp

**Hanz Günter Martin**

Deutsche Gesellschaft zur Förderung der  
Unterwasserarchäologie e.V., Deutschland;  
martin@degawa.org

**Michaela Reinfeld**

Deutsches Archäologisches Institut,  
Römisch-Germanischen Kommission,  
Deutschland; michaelareinfeld@yahoo.de

**Noelle C.Y. Ng 吳卓**

Antiquities & Monuments Office, Hong Kong,  
China; ncyng@lcsd.gov.hk

**Lina Liu 娜**

Law School, Xi'an Jiaotong University, Shaan'xi  
Province, China; Lydia\_lina223@aliyun.com

**Ligaya S.P. Lacsina**

Maritime and Underwater Cultural Heritage  
Division, Museum of Anthropology, National  
Museum of the Philippines;  
gaylacsina@gmail.com

**Ziad M. Morsy**

Alexandria Centre for Maritime Archaeology  
and Underwater Cultural Heritage, Faculty of  
Arts, Alexandria University (University of  
Southampton), Egypt;  
zmm1g16@southampton.ac.uk

**Hironobu Kan**

Research Center for Coastal Seafloor, Kyushu  
University, Japan; kan@scs.kyushu-u.ac.jp

**Clara Fuquen-Gomez**

National University of Colombia (University of  
Southampton), Colombia;  
clara.fuquen@gmail.com

**T. Kamal Kummara de Zoysa**

Maritime Archaeological Unit, Central Cultural  
Fund, Galle, Sri Lanka; kamalzoysa@yahoo.com

**Charlotte Dixon**

The British Museum (University of  
Southampton), United Kingdom;  
*c.dixon@soton.ac.uk*

**Arnold van Rooijen**

Deltares, Netherland/Australia;  
*arnold.vanrooijen@deltares.nl*

**Andrew Viduka**

National Historic Heritage Section,  
Department of Environment, Australian  
Government, Australia;  
*andrew.viduka@environment.gov.au*

**Amandine Colson**

Institut der Leibniz-Gemeinschaft, Deutsches  
Shiffahrtsmuseum, Deutschland;  
*colson@dsm.museum*

**Charlotte Minh Hà PHAM**

Asia Research Centre, Murdoch University,  
Vietnam/Australia; *charlotte.pham@gmail.com*

**Lucy Blue**

Centre for Maritime Archaeology, University  
of Southampton; Honor Frost Foundation,  
United Kingdom; *lkb@soton.ac.uk*

**Robert Holtzman**

Mythic Gear, Inc.; Indigenous Boats - small  
craft outside the western tradition, Maine,  
USA; *rsholtzman@gmail.com*

**Phil Buck**

Buck Expeditions, Bolivia;  
*https://www.facebook.com/  
profile.php?id=100009285507555&fref=ts*

**Robert Domżał**

Dział Historii Budownictwa Okrętowego,  
Narodowe Muzeum Morskie w Gdansku,  
Polska; *r.domzal@nmm.pl*

**José Matés Luque**

Freelance archaeologist, Catalunya, España;  
*j.matesluque@yahoo.es*

**Matko Čvrljak**

Maritime archaeology, Vikingskibsmuseet,  
Denmark; *macvrljak@gmail.com*

**YongHwa Jung 정용화**

West SEA Cultural Heritage Division, National  
Research Institute of Maritime Cultural  
Heritage, 학예연구소 at 국립해양문화재연구  
소, Korea; *pkm228@hanmail.net*

**Ramin Adibi**

Journal of Archaeology of Maritime Landscape  
Magazine, Isfahan, Iran;  
*ramin.adibi2012@gmail.com*

**Andreas Kallmeyer Bloch**

Exhibition team and Maritime archaeology,  
Vikingskibsmuseet, Denmark;  
*akb@vikingskibsmuseet.dk*

**Tomislav Šola**

The Best in Heritage, Project of influence;  
European Heritage Association, Hrvatska;  
*director@thebestinheritage.com*

**Darko M Kovačević**

Alexandria Centre For Maritime Archaeology  
and Underwater Cultural Heritage, University  
of Alexandria, Egypt; Srbija;  
*darkokvcvc@gmail.com*

**Rihards Vidzickis**

Vienkoču parka, Kokamatniecibas muzejs  
(Woodcraft museum), Vienkoči, Ligatnes,  
Latvija; *info@vienkoci.lv*

**Aleksandar Sajdl**

Underwater archaeologist, Novi Sad, Srbija;  
*aleksandar.sajdl@gmail.com*

**Antonije Pušić alias Rambo Amadeus**

Sailing school Jugole Grakalić  
([www.ramboamadeus.com](http://www.ramboamadeus.com)), Herceg Novi,  
Črna Gora; [antonije.pusic@ramboamadeus.com](mailto:antonije.pusic@ramboamadeus.com)

**Theodor Rokov**

Department of Maritime History and  
Archaeology, Varna Museum of Archaeology,  
Varna, Bulgaria; [teorokov@abv.bg](mailto:teorokov@abv.bg)

**Harri Luukkanen**

Research economist and expert of  
techno-economic studies, bark boats and a  
life-long paddler, Helsinki, Suomi;  
[harriluukkanen@gmail.com](mailto:harriluukkanen@gmail.com)

**Jeremy Ward**

The Canadian Canoe Museum/ Le musée  
Canadien du canot, Peterborough, Ontario,  
Canada; [jeremy.ward@canoemuseum.ca](mailto:jeremy.ward@canoemuseum.ca)

**Nuša Saje**

Conservation Centre, Institute of the Protection  
of Cultural Heritage of Slovenia, Ljubljana,  
Slovenija; [nusa.saje@gmail.com](mailto:nusa.saje@gmail.com)

**Gordana Karović**

Muzej nauke i tehnike / Museum of Science  
and Technology, Beograd, Srbija;  
[Gordana.Karovic@MuzejNT.RS](mailto:Gordana.Karovic@MuzejNT.RS)

**Massimo Capulli**

Dipartimento di studi umanistici e del  
patrimonio culturale, Università degli studi di  
Udine, Italia; [massimo.capulli@uniud.it](mailto:massimo.capulli@uniud.it)

**Jelena Čelebić**

Centar za konzervaciju i arheologiju Crne gore,  
Cetinje, Črna Gora; [jelena.celebic.hn@gmail.com](mailto:jelena.celebic.hn@gmail.com)

**Barbora Machová**

Archeologický Ústav AV ČR Praha, Česko;  
[machova@arup.cas.cz](mailto:machova@arup.cas.cz)

**Annie Dumont**

Laboratoire Arthehis UMR CNRS, University of  
Burgundy, France; [annie.dumont@u-bourgogne.fr](mailto:annie.dumont@u-bourgogne.fr)

**Barbara Davidde**

Nucleo per gli Interventi di Archeologia  
Subacquea (NIAS) dell'Istituto Superiore per la  
Conservazione e il Restauro (ISCR) – Ministero  
dei Beni e delle Attività Culturali e del  
Turismo, Roma, Italia;  
[barbara.davidde@beniculturali.it](mailto:barbara.davidde@beniculturali.it)

**Marion Foucher**

Laboratoire Arthehis UMR CNRS, University of  
Burgundy, France; [marionfoucher@hotmail.fr](mailto:marionfoucher@hotmail.fr)

**Oksana Turchanina**

Faculdade de Arquitetura, Universidade de  
Lisboa, Portuguese;  
[oksana.turchanina@fa.ulisboa.pt](mailto:oksana.turchanina@fa.ulisboa.pt)

**António Castelbranco**

Faculdade de Arquitetura, Universidade de  
Lisboa, Portuguese; [aacastelbranco@gmail.com](mailto:aacastelbranco@gmail.com)

**Andzrej Pydyn**

Zakład Archeologii Podwodnej, Instytut  
Archeologii, Uniwersytet Mikołaja Kopernika,  
Torun, Polska; [pydyn@umk.pl](mailto:pydyn@umk.pl)

**Ulrike Guerin**

Convention on the Protection of Underwater  
Cultural Heritage (2001), Paris, France;  
[u.guerin@unesco.org](mailto:u.guerin@unesco.org)

**Iwona Pomian**

Działa Badań Podwodnych, Narodowe  
Muzeum Morskie w Gdańsku, Polska;  
[i.pomian@nmm.pl](mailto:i.pomian@nmm.pl)



**Andres Rõigas**

Viljandi kultuuriakadeemia, Tartu Ülikool,  
Tartu, Eesti; *andres.roigas@ut.ee*

**Erich Palm**

Riigiasutus, Puiatu, Viljandimaa, Eesti;  
*erich.palm@?.ee*

**Aado Lintrop**

Eesti Kirjandusmuuseum, Tartu, Eesti;  
*aado@folklore.ee*

**Heiki Pärdi**

Eesti Vabaõhumuuseum, Raikküla, Tallinn,  
Eesti; *heiki@evm.ee*

**Luka Bekić**

Međunarodni centar za podvodnu arheologiju  
u Zadru; UNESCO Category II Centre, Zadar,  
Hrvatska; *lbekic@icua.hr*

**Mladen Pešić**

Međunarodni centar za podvodnu arheologiju  
u Zadru; UNESCO Category II Centre, Zadar,  
Hrvatska; *mpesic@icua.hr*

**Henrik Pohl**

Kuratorium Pfahlbauten UNESCO-World  
Heritage Prehistoric Pile Dwellings around the  
Alps, National Management Austria, Wien,  
Austria; *pohl@palafittes.at*

**Anne-Kathrin Piele**

Archaeologist and independent researcher in  
the field of Early Watercraft, Berlin,  
Deutschland; *annekathrin.piele@yahoo.de*

**Ekaterina A. Kashina**

Государственный исторический музей / State  
historical Museum, Moscow, Russia;  
*eakashina@mail.ru*

**Dunja Zorman 達達華**

Sinološko društvo Yuan, Oddelek za azijske  
študije Filozofske fakultete, Univerza v  
Ljubljani, Slovenija; *dunja.zorman@gmail.com*

**Gytis Piličiauskas**

Lietuvos istorijos institutas, Valstybinis  
mokslinių tyrimų institutas, Vilnius, Lietuva;  
*gytis.piliciauskas@gmail.com*

**Dmitriy Kobalia**

Відділ охорони пам'яток Національний  
заповідник «Хортиця», Запоріжжж, Україна /  
Department of protection of monuments of the  
National reserve "Khortytsia", Zaporizhzhya,  
Ukraina; *kobalia@i.ua*

**Sergey Olkhovskiy**

Институт археологии, Российская академия  
наук, Москва, Россия / Archaeological  
Institute of Russian Academy of Science,  
Moscow, Russia; *ptakkon@yandex.ru*

**Nataša Rebernik**

Universidad de Deusto, Bilbao, Espanya;  
*natasa.rebernik@deusto.es*

**Lailan Jaklič**

Oddelek za arheologijo, Filozofska fakulteta,  
Univerza v Ljubljani; ArtBrand LaniXi,  
Slovenija; *jaklic.lailan@gmail.com*

**Zdravka Georgieva**

Ancient museum Nessebar; Nessebar, Bolgaria;  
*zdravka.h.georgieva@gmail.com*

**Alexandra Biar**

Archéologie des Amériques UMR 8096 - CNRS  
/ Université Paris 1 - Panthéon-Sorbonne, Paris,  
France; *alexbiar@hotmail.com*

**Nikola Paskali**

Diving center Akvatek, Ohrid, Makedonija;  
*n.paskali@hotmail.com*

**Institutional Ambassadors**

**Muzej nauke i tehnike / Museum of Science and Technology**  
**Skender-begova 51, 11000 Beograd, Srbija**

*Tel: +381 3037-850, 3037-950 / (mnt@muzejnt.rs) / www.muzejnt.rs*

**Deakin International Europe, Deakin University, Melbourne, Australia**  
**Skovbovængets sidealle 23, Roskilde, 4000, Denmark**

*Ursula Lorentzen, Director ((ursula.lorentzen@deakin.edu.au) /  
<http://www.deakin.edu.au/international-students/contact-us/europe-office>*

**Faculdade de Arquitetura, Universidade de Lisboa, Portugal**

**Rua Sá Nogueira, Pólo Universitário, Alto da Ajuda 1349-063 Lisboa** *Tel: +351 931 980 857 / Oksana Turchanina, European Project Coordinator (oksana.turchanina@fa.ulisboa.pt) /  
[www.fa.ulisboa.pt](http://www.fa.ulisboa.pt)*

**Zakład Archeologii Podwodnej, Instytut Archeologii, Uniwersytet Mikołaja**  
**Kopernika, Szoza Bydgoska 44/48, 87-100 Toruń, Polska**

*Tel: +48 56 611 39 71 / Andzrej Pydyn (pydyn@umk.pl) /  
<https://www.archeologia.umk.pl/pracownicy/pracownicy-instytutu-archeologii?id=337120>*

**Dział Badań Podwodnych, Narodowe Muzeum Morskie w Gdańsku**  
**Ołowianka 9-13, 80-751 Gdańsk, Polska**

*Tel: +48 58 301 86 11 / Iwona Pomian (i.pomian@nmm.pl) / <https://en.nmm.pl>*

**Nucleo per gli Interventi di Archeologia Subacquea (NIAS) dell'Istituto Superiore**  
**per la Conservazione e il Restauro (ISCR) – Ministero dei Beni e delle Attività**  
**Culturali e del Turismo, via di San Michele, 25 00153 Roma, Italia**

*Tel: +39 6 672 363 00 / Barbara Davidde (barbara.davidde@beniculturali.it) /  
<http://www.icr.beniculturali.it/pagina.cfm?usz=&uid=5>*

**Kuratorium Pfahlbauten, UNESCO-Welterbe Prähistorische Pfahlbauten um die**  
**Alpen, National management Austria c/o NHM Wien**

**Burgring 7 1010 Wien, Austria**

*Tel: +43 1 521 77 295 / Cyril Dworsky (dworsky@pfahlbauten.at) / <https://www.pfahlbauten.at>*

**Eesti Meremuuseum; Mustamäe tee 143-55, Tallinn, Eesti**

*Tel: +30 210 92 35 105 / Liisa Randmaa (liisa.randmaa@meremuuseum.ee) /  
<http://meremuuseum.ee/en/>*

**Deutsches Archäologisches Institut, Römisch-Germanischen Kommission**  
**Palmengartenstraße 10-12, D-60325, Frankfurt am Main, Deutschland**

*Tel: +49 069 975 81 80 / Roman Scholz (roman.scholz@dainst.de) /  
<https://www.dainst.org/standort/-/organization-display/ZI9STUj61zKB/14595>*

**Antenna office in Sarajevo, UNESCO Regional Bureau for Science and Culture in**

**Europe, Venice UNESCO organization**  
**Zmaja od Bosne bb, UN House, Sarajevo, Bosna i Hercegovina**  
Tel: + 39 41 260 15 11 / *Siniša Šešum (s.sesum@unesco.org) /*  
*<http://www.unesco.org/new/en/venice/home/>*

**Convention on the Protection of Underwater Cultural Heritage (2001)**  
**7, place de Fontenoy, 75352 Paris 07 SP, France**  
Tel: + 33 145 681 351 / *Ulrike Guerin (u.guerin@unesco.org) /*  
*<http://www.unesco.org/new/en/culture/themes/underwater-cultural-heritage/contact/>*

**Árpád Múzeum Kossuth Lajos utca 34, 2300 Ráckeve, Magyarország**  
Tel: +36 24 519 035 / *Attila J. Tóth (roncsok@yahoo.com) /*  
*<https://www.danubetourism.eu/arpad-museum-rackeve/>*

**Archeologický Ústav AV ČR Praha**  
**Letenská 4, 11801 Praha 1, Česká republika**  
Tel: +420 257 014 331 / *Barbora Machová (machova@arup.cas.cz) /*  
*<https://www.arup.cas.cz/>*

**Laboratoire ARTEHIS UMR CNRS, Université de Bourgogne**  
**59 rue Vannerie, 21000 Dijon, France**  
Tel: +420 257 014 331 / *Annie Dumont (annie.dumont@u-bourgogne.fr) /*  
*<http://en.u-bourgogne.fr>*

**Dipartimento di studi umanistici e del patrimonio culturale, Università degli studi di Udine; Vicolo Florio 2/b, 33100 Udine, Italia**  
Tel: +39 0432 556619 / *Massimo Capulli (massimo.capulli@uniud.it) /*  
*<https://www.uniud.it/it/ateneo-uniud/ateneo-uniud-organizzazione/dipartimenti/dium/dipartimento/DIUM>*

**Međunarodni centar za podvodnu arheologiju u Zadru; UNESCO Category II Centre**  
**Božidara Petranovića 1, HR-23000 Zadar, Hrvatska**  
Tel: +385 23 250 486 / *Luka Bekić (lbekic@icua.hr) /*  
*<https://icua.hr>*

**Fakulteta za računalništvo in informatiko, Univerza v Ljubljani**  
**Večna pot 113, SI-1000 Ljubljana, Slovenija**  
Tel: +386 1 479 8000 / *Franc Solina (franc.solina@fri.uni-lj.si) /*  
*<https://fri.uni-lj.si/en> / <https://fri.uni-lj.si/en/laboratory/lrv>*

**Center za raziskave scenskih umetnosti Delak**  
**Župančičeva ulica 10, SI-1000 Ljubljana, Slovenija**  
Tel: +386 9221 6307 / *Dragan Živadinov (info@delak.eu) /*  
*<http://www.postgravityart.eu>*

Государственный исторический музей / **State historical Museum**

**Красная площадь / Red Square 1, Moscow, Russia**  
*Tel: +7 495 6981 846 / Ekaterina Kashina (ekashina@mail.ru) /*  
*<http://en.shm.ru>*

**European Association for Asian Art and Archaeology**  
**Aškerčeva cesta 2, SI-1000 Ljubljana, Slovenija**  
*Tel: +386 1 241 1499 / President Dr. Nataša Vampelj Suhadolnik (info@ea-aaa.eu) /*  
*<http://as.ff.uni-lj.si/english/english>*

**ICOMOS - Slovenija**  
**Poljanska 40, SI-1000 Ljubljana, Slovenija**  
*Tel: +386 1 476 85 00 / President Dr. Sonja Ifko (sonja.ifko@fa.uni-lj.si) /*  
*<http://en.icomos.si>*

**Diving center AKVATEK**  
**Car Samuil 82, 6000 Ohrid, Makedonija**  
*Tel: +389 77 800 539 / President Nikola Paskali (n.paskali@hotmail.com) /*  
*[www.akvatek.mk](http://www.akvatek.mk)*

## Contents

<b>Proposal of the Initiative</b>	<b>13</b>
Introduction . . . . .	13
Short history of development of the idea . . . . .	14
Vision, purpose and mission . . . . .	19
Content and topic of Initiative . . . . .	22
Skin boats and some representative variations . . . . .	23
Bark boats and their' representative variations . . . . .	28
Logboats and some representative variations . . . . .	30
Reed boats and some representative variations . . . . .	35
Rafts and some representative variations . . . . .	40
Plank boats and some representative variations . . . . .	45
Other . . . . .	49
Strategic objectives . . . . .	53
Short-term objectives . . . . .	53
Mid- and Long-term objectives . . . . .	55
Spatial factors of mission and operation . . . . .	57
Research methods and techniques . . . . .	57
Forms and scope of activities . . . . .	57
Scientific research . . . . .	58
Database/Network . . . . .	59
Knowledge exchange: organisation, scientific conferences, journal, web based public communication . . . . .	61
Original Early Watercraft Conservation and Protection . . . . .	61
Promotion, Popularisation and Education . . . . .	62
Museums, heritage parks, tourism and sports – sustainable and ecological use . . . . .	63
<b>Selected basic bibliography</b>	<b>65</b>
<b>References</b>	<b>65</b>

## Proposal of the Initiative

### Introduction

The idea of the Initiative is based on 20 years of topic forming and developing which culminated in a paper given at the World Cultural Heritage Conference EUROMED 2014 (supported and organized by ISPRS, CIPA, ICOMOS, ICOM, ICCROM) which was held in November 2014 in Lemessos, Cyprus. The paper was recognised as the best paper at the Conference and was awarded the Werner Weber Award.<sup>1</sup>

The findings of prehistoric vessels (e.g. Early Watercraft), logboats and dugout canoes as the oldest evidence (logboat from Pesse, Netherland) as the other forms of watercraft (reed-, skin-, bark- boats, rafts, etc.) all over the world mark the beginning of **shipbuilding** and **transportation** traditions and in the sense of far-reaching significance as well as **navigation, mobility, orientation, networking, conquering, colonisation, travelling** and consequently also the other inventions. Anthropological theory, however, even without the aid of real finds is widely accepted and claims that the watercraft began to be in use for at least 60k years, and some of them even state' that watercraft has been used even by *Homo erectus* from 800k years ago.

This great story of transportation on water, which is closely linked to man's traditional coexistence with water and his life in aquatic environments has a strong symbolic meaning since the vast majority of humanity lives near the seas, lakes and rivers. In the general story of shipping traditions, shipbuilding and watercraft typology in the framework of world heritage, the simple prehistoric vessels or Early Watercraft have not been paid enough attention so far, although they definitely deserve it, as they represent the origins of the mankind's navigational tradition.

A special segment of research into shipbuilding traditions are the earliest vessels used by man in the past. These vessels from prehistoric times used to be made from tree trunks, most frequently oak (*Quercus*), pine (*Pinus*), silver fir (*Abies Alba*), spruce (*Picea*) and linden (*Tilia*) wood. Today similar vessels are still being produced in different parts of the world. In some regions they are an existential necessity, e.g. on some African and Asian rivers

---

<sup>1</sup>Paper was published in International Journal of Heritage in the Digital Era, volume 3 number 4, 2014 by Miran Erič: **New reflections on the protection of World Heritage in the future: Global symbolic meaning of autochthonous and indigenous origins of water navigation**, p. 597-612. [On line] Available at: <[https://www.academia.edu/11655103/New\\_reflections\\_on\\_the\\_protection\\_of\\_World\\_Heritage\\_in\\_the\\_future\\_Global\\_symbolic\\_meaning\\_of\\_autochthonous\\_and\\_indigenous\\_origins\\_of\\_water\\_navigation](https://www.academia.edu/11655103/New_reflections_on_the_protection_of_World_Heritage_in_the_future_Global_symbolic_meaning_of_autochthonous_and_indigenous_origins_of_water_navigation)> [20. June 2015].

and lakes and some islands in the Pacific. Elsewhere the preservation and protection of cultural heritage and the tradition of their use is the main aim, e.g. in Estonia, France and Pennsylvania. They bear a thematic mark and a local colour. Since what we are dealing with is natural coexistence between man and water – waterways being a natural communication network enabling faster transportation, particularly of cargo, compared to journeying on foot or on horseback - the credit for this invention cannot be given to a single people. It lies in the core of human heritage- an implement of key importance for the survival of the human race, most likely one with the longest history.

There is no available data on the overall number of the logboats discovered so far, but thanks to Béat Arnold from Neuchâtel, who has been gathering information from his colleagues, it is known that more than 3000 logboats have been found in Europe. The oldest dates back to c. 8000 BC and was discovered in Pesse in the Netherlands, and similar were found in Africa and China. Several hundred of the unearthed logboats are prehistoric, many originated in antiquity, most of them, however, are medieval or modern fabrications. The finds have most frequently been preserved in marshes and other aquatic environments, such as lakes, rivers, bogs and brooks, which prevent exposure of wood to the air. Finds have also been made in marine environments such as estuaries, bays and even in the open sea.

### Short history of development of the idea

Deep roots are not reached by the frost

---

— *John Ronald Reuel Tolkien*

The initial and most important impulse for development of the idea for the Initiative was the discovery of an oak logboat in 1989, unearthed during the extraction works in the Mura river backwater in Hotiza near Lendava in NE part of Slovenia. It was a clear signal when it was dated by <sup>14</sup>C in Radiocarbon laboratory in Rudjer Bošković Institute in Zagreb. The date of 7630±150 BP show's that logboat is one of the sixth oldest logboat in the world and this is when the concept for the idea began.

After collecting all published discoveries of dugout boats in the 19<sup>th</sup> and 20<sup>th</sup> centuries right up until today, the first of which was found and recorded by Franz Hochenwarth in 1827, it was clear that *Ljubljansko barje* is very rich in Early Watercraft finds and has a similar high density of prehistoric pile- dwellings settlements. As pile- dwelling from Ig is one part of the great story about **Prehistoric Pile dwelling around the Alps** (Switzerland,



*Figure 2: Mesolithic logboat from Hotiza when was discovered in 1989. (Photo: Marija Lubšina Tušek)*

Slovenija, Deutschland, Österreich, France, and Italia) as heritage monument on UNESCO World Heritage List, also the high concentrations of logboats – we have descriptions of more than 70 logboats and few plank boats and ships – are the artefacts of very important, but invisible and unrecognized heritage.

During the late 1980s and 1990s the dedicated and enthusiastic efforts of a small number of individual researchers interested in Early Watercraft progressed the subject significantly. One of the most important pieces of work is certainly that of Béat Arnold from Neuchâtel who as early as in the 1970s systematically recorded known discoveries of logboats in Europe. We are strongly bound to continue his work and establish systematic research conditions and forms of action. He produced a comprehensive dataset of more than 3000 logboats, dugout canoes, planking boats and other small and early watercrafts, which was described, recorded, identified, and/or researched all over Europe.

As a foundation for Arnold's database it is necessary to mention also a few other researchers from different countries who started locally and regionally systematically collecting Early watercraft, as Tolvo Itkonen from Suomi, Hans Suder, Detlev Ellmers, Christian Hirte and Timm Weski from Deutschland, Jan Lanting from Netherland, Una MacDowell, Anna Brindley and Niall Gregory from Ireland, Malcolm F. Fry from Northern Ireland, Sean McGrail from United Kingdom, Waldemar Ossowski and Jerzy Litwin



from Polska, Ole Crumlin Pedersen and Søren Andersen from Denmark, Marco Bonino and Ottavio Cornaggia Castiglioni from Italia, Louise Bonnamour and Philippe Bonnin from France, Davorin Vuga from Slovenija, and then we have several more researchers who published discoveries of vessels occasionally.

There is also a lot of researchers around the world with great stories of nearly 7000y old Dufuna logboat from Zimbabwe, the oldest in Africa, published by Peter Breunig, almost as old logboat from Kuahuiqiao near Hangzhou (Zhejiang province) in the lower Yangze River in China, published by Jiang Leping and for example Ryan Wheeler's 100 dugout canoes from Newnans Lake near Gainesville in Florida published in 2003, dated from 5000y to 2300y ago. Also in North America it is possible to find nice and great project *Mishoonash&Dugauts* conducted by *Massachusetts Board of Under-*



Figure 3: Mesolithic logboat from Kuahuiqiao, China, was discovered in 1990. (Photo: Fig. 7 from article: Jian Leping, and Liu Li, The discovery of an 8000-year-old dugout canoe at Kuahuiqiao in the Lower Yangzi River, China. *Antiquity*, 2005, 79, 305.)

*water Archaeology* with a list of 12 subordinate projects about researching local areas, experimental studies and conservation of dugout canoes. It is clearly shown that throughout the world there is a multitude of individual stories talking about an important phenomenon.

But these efforts, especially in Europe, and from archaeological point of view, were not the only influence on the development of the idea. There is also important influence of individuals as Gerhard Kapitän, who made amazing ethnological systematic and synthetic work on traditional watercraft in Sri Lanka and in this early years show the way of understanding methodology of scientific research of Early Watercraft. Similar synthetic work can be expected also from Béat Arnold with his study of bark boats in Malaysia which should be presented in near future. With the short tour of web searching it is clearly shown that all over the world are a lot of people focused on researching the incidence of boats today, but without reflections on prehistoric roots of this phenomenon.

Experimental kind of understanding the philosophy, technology and operational implementation issues of reconstruction based on archaeologically researched watercraft or

producing just in the usual form is widespread through the world. The most important and long living tradition of experimental work we can find in France where Philippe Bonnin with colleagues leads the projects within the framework of GRAS - *Groupement de chercheurs archeologiques subaquatiques*, for more than 20 years now, where they made reconstructions of almost all oldest logboats found in France. The efforts of Aivar Ruukel from the Estonian national park Soomaa are also highly important. They maintain continuing education and promotion of a specific type of logboat, so called *Habjaas*, that has developed in the E and NE part of the Baltic Sea and the hinterland in last centuries. Traditionally, every year on the experimental workshops they produce a new *Habjaas* and use it for renting to visitors and longer trips around the nearby rivers and lakes.

Important influence on the developing of the Idea about this initiative is also due to a multitude of individuals across the globe who, fueled by their own volition and enthusiasm consistently collect data and publications from around the world about early watercraft and their incidence in the present days and publish them on their websites or blogs. One of the most important is certainly the blog *Indigenous boats* created by Bob Holtzman,<sup>2</sup> who created, just by his own enthusiasm, a worldwide-ranging collection of simple vessels, including both: early watercraft as well as all versions up to the present day, and today can be seen as indigenous or native or autochthonous. This is also a form that is completely random also very close to the phenomenon networking into a unified conception of evolution and invention, which can be seen under a common name such as Early Watercraft. But this is not the only inspirational initiative on web sites as we can find also the page of *Eyemouth Maritime Centre* from Scotland – World of Boats – where it is possible to find digital collection with more than 400 types of boat and more than 300 models from all over the World.

Finally there is also important impulse which helped in the past to encourage reflection and helped shape and create the Initiative in the present frame. . This is an Art based idea with the roots in Trbovlje, Slovenia where at the end of seventies of 20<sup>th</sup> century started to grow and continued in Ljubljana. It is called the *Neue Slowenische Kunst* collective, where musicians (Laibach), painters (Irwin), theatre actors (Scipion Nasice Sisters Theatre), philosophers (Department of Pure and Applied Philosophy), architects (Builders) and designers (New Collectivism) create a new art movement.<sup>3</sup> Highly theoretically and

---

<sup>2</sup>As he describes himself: *Canoelist, marketing communications consultant, author of outdoor books and articles*; [On line] Available at: <[http://www.networkedblogs.com/blog/indigenous\\_boats](http://www.networkedblogs.com/blog/indigenous_boats)> [20. June 2015].

<sup>3</sup>[On line] Available at: <[http://en.wikipedia.org/wiki/Neue\\_Slowenische\\_Kunst](http://en.wikipedia.org/wiki/Neue_Slowenische_Kunst)> [22. June 2015].



Figure 4: In the National park Soomaa in Estonia each year they make a new *habjaas* (Photo: Ilmar Saabas).

philosophically based movement in 1992 created the *NSK State* with following basic premises: "*The NSK State is a state in time, a state without territory and national borders, a sort of »spiritual state«. Beside the members of NSK, the right to NSK citizenship belongs to thousands around the world, to people of different religions, races, nationalities, sexes and beliefs. The right to citizenship is acquired through the ownership of an NSK passport.*"<sup>4</sup> Inspiration also came from idea about a production house of Dragan Živadinov which explores postgravity art and outlines space culturalisation. It produces different sorts of contemporary art practice in the field of postgravity art: performances, exhibitions, musical and theatrical productions. Delak's main mission is the culturalization of space, which enables merging of art and science in real space. The historical foundation of space culturalisation is the European pioneer of spaceflight Herman Potočnik - Noordung, the engineer of the first geostationary space station. For more than ten years, Živadinov is intensely cooperating with Yuri Gagarin cosmonaut training centre, Star city. He finally presented and realized the Cultural Centre of European Space Technologies in Vitanje, Slovenia.<sup>5</sup>

At the end, within the above-mentioned influences huge projects and scientific research, published results, different kind of databases, arte- fact's in museums, experimental created copies and reconstructions, enthusiastic collectors and material of their works, individual oriented amateurs research, finished in past century can be clearly seen, but also, Museums' and Parks' efforts to preserve heritage as well as possible are not to be ignored..

<sup>4</sup>[On line] Available at: <[http://www.passport.nsk.si/en/about\\_us](http://www.passport.nsk.si/en/about_us)> [22. June 2015].

<sup>5</sup>[On line] Available at: <[http://en.wikipedia.org/wiki/Cultural\\_Centre\\_of\\_European\\_Space\\_Technologies](http://en.wikipedia.org/wiki/Cultural_Centre_of_European_Space_Technologies)> [22. June 2015].

But on the other hand, all the data collected, all efforts of individuals(both scientists and enthusiasts) are not interconnected into an unified scientific field, neither is institutionalised into any form of organisation or association which would make proving how important an invention early watercraft really were in relation to all later human development. Therefore there is little awareness how later developments (**shipbuilding, transportation, navigation, mobility, orientation, networking, conquering, colonisation, travelling** and consequently also the other inventions) are linked to Early Watercraft. Early Watercraft remains vitally incorporated into the very foundation of our everyday living.

**Mankind simply must be aware of the importance of this phenomenon.**

### **Vision, purpose and mission**

Sometimes the door closes for us so we might turn and see an open gate to wider field of opportunity

---

— *Brendan Burchard*

In the recent decades increasing awareness of the significance of world heritage protection has significantly contributed to an update of theoretical premises and concepts and a broader understanding of heritage.

It has ceased to be understood in a narrow sense as romantic collecting of artefacts, as practiced in previous centuries. We have become aware that our common heritage is tangible as well as intangible. Intangible heritage manifests itself everywhere in the world through folk festivals (e.g. celebration of new year, bonfires, worship of symbols, tomato festivals, etc.) and through understanding of traditions and activities, which have developed in the course of many centuries and millennia (arts, crafts and similar).

We have finally come to understand that the first object, the first implement man was able to use to gain a better control of his dwelling environment, employed primarily for travelling purposes and for conquering new territories, played a crucial role in the liberation of man's body and mind. It made it possible for his physical body to travel much farther than what his mere physical existence would have allowed.

By means of the first tangible communication tool – the Early Watercraft – man has freed himself of the feeling of impotence and restrictedness in space and time. By being able to use the arteries of the global water system, he was able to reach the most distant points of the earth. Today this liberation of mind drives him on journeys into new

unexplored territories, in different types of vessels. A worthy tribute to one of the most important human inventions is the establishment of the Global Prehistoric Vessel Research Institute and the Global Early Watercraft Heritage Park.

I. Our **vision** is to organise world wide organisation which will include and connect:

a. Individual scientists, experts and specialists who research all aspects of Early Watercraft invention and development from very early phase before the evolution of ship construction and tradition of navigation. Important and phenomenological point of view is also that this early shape of Early Watercraft did not change in principal purpose and kind of use until today, so in that scientific organisation all people who explore the phenomenon in all its modalities today should be also involved. As the initiative covers a very broad range of knowledge, scientific disciplines, research prehistory, history, modern time, evolution and behaviour: archaeology (underwater, experimental...), anthropology, ethnology, history, art history, heritology, museology, geology (glaciology, hydrology ...), geography, geodesy, education, philosophy, physics, chemistry, biology (dendrochronology, palynology), psychology (gender studies, behaviour), ecology, IT and computer science, arts, social science, humanities, etc, should be involved. In fact all disciplines which can highlight this phenomenon and help understand **when** and **how** Early Watercraft was invented, **why** it did not change until 2015 – and will not change in the future (!) – on one hand, and **what** has contributed on the other hand, that it has developed into spacecraft and all future space travelling accesses and possibilities to explore space. Least but not last, registration and systematisation of all forms of Early Watercraft which have evolved should be committed.

b. Professional Institutions, Universities, Museums, Natural and Cultural parks that are dedicated to the evolution of shipbuilding and tradition of navigation as fundamental or partial goal, be it research, protection, education or promotion.

c. Local communities where use of Early Watercraft is still part of modern communities economy and needs for live, and local communities where they recognise the importance of promotion of their own culture and history and use it as an opportunity for new kind of cultural education and promotion of local or regional indigenous and autochthonous living.

d. Individual enthusiasts and institutions which utilise the 21<sup>st</sup> century paradigm of heritage protection and promotion to promote the sports and culture/heritage tourism by means of building or operating reconstructions or copies of the Early Watercraft or futuristically redesign their original shapes.

**Nothing in this world functions without the involved support  
of local communities and enthusiasts!**

II. The main and basic **purpose** and **mission** of the Initiative is to change the general amnesia of humanity, that completely overlooked the paramount importance of the discovery of the possibility of navigation and the invention of tools for navigation - **Early Watercraft**. This fact which is possibly due to their simplicity, obviousness, and widespread usage! In the future, the Initiative should return this awareness to mankind.

The initiative must return to humanity the awareness that a multitude of inventions - including navigation, transportation, conquest, networking, bike, compass, astronomy, navigation etc would not have been possible without the invention of Early Watercraft. This invention is at least as important as the inventions of fire control, hand tools and weapons, art (painting, music, sculpture), clothing, housing medicine and agriculture. However, even a cursory review of the masses of the world's lists - even those more serious - of the oldest and the most important inventions, shows that they do not include Early Watercraft.

**Early Watercraft are definitely one of the five most  
important and oldest inventions of humankind.**

Preservation and promotion of cultural heritage has advanced in all parts of Europe in the last two centuries, and particularly so in the last two decades. In the field of cultural tourism, which has lately been increasing as a result of greater awareness and higher demands of the general public, well-preserved and presented cultural heritage is becoming an important tool for obtaining a rounded-up picture of the ways of life of different cultures and peoples.

The story, which can be discerned through the navigation tradition of the *Ljubljansko barje* and its material heritage in the form of logboats and other vessels, is closely connected to human cohabitation with water and water environments. Since more than 70% of the world population live on or beside the ocean, lakes and river shores, vessel heritage and use of global communication arteries should be of interest to most people. The available data show that many logboats in Europe and elsewhere are preserved in collections of specialised museums.

There exist a handful of experimental groups of archaeologists and anthropologists (France, Estonia, Denmark, the Netherlands, Pennsylvania etc.) who have made copies of

particularly notable dugouts upon their discovery. On the global scale, heritage institutions connected with water tend to be highly frequented and enjoy a great deal of public attention. Among the most prominent in Europe are the Vasa Museum in Stockholm, the Mary Rose Museum in Portsmouth, the Viking Ship Museum in Roskilde, Denmark, and others. The great stories they tell refer to particular places and times; Vasa and Mary Rose speak about two maritime superpowers of the 17<sup>th</sup> century, whereas Roskilde glorifies Viking conquests in the early Middle Ages. The North American canoe, now mainly fabricated from new materials (aluminium, plastic) tells the great story of North American Indians. The many "wonders of the world" are similar in this respect. The pyramids of Giza talk about the fascinating building competence of the people living 4000 years ago, the Neolithic and Bronze Age Stonehenge attracts with yet unrevealed mystery of its symbolic meaning and meaning of space.

But all these great stories are fixed in time and space! The idea of a thematic museum or a thematic park, dedicated to prehistoric vessels as global heritage, has not yet been put in practice. The logboat as the roots of man's liberation and the symbol of the oldest meaning of communication has not received its due consideration in the study of navigation traditions, shipbuilding, typologies etc.

Why not? Is it too simple? Is it perhaps not enough of a challenge for professionals? Or is it because it usually appears outside archaeological contexts and is, therefore, less interesting for academic research? Maybe this vessel is not classy enough, a mere rural implement, too mundane to deserve attention? The prehistoric logboat, seen as a minor issue in the perspective of researchers' ambitions, cannot become a great story. However, since technology has made such great leaps forward in recent years, it can now offer a highly complex multilayer foundation for global interconnections and provide a platform for a joint approach to the research of man's first communication implements, the Early Watercraft (rafts, bark boats, logboats, reed boats, skin boats, plank boats ...)

### **Content and topic of Initiative**

Initiative will however cover the invention of Early Watercraft and its developments from early beginnings in all its dimensions. Below is presented the various types of Early Watercraft as recognised by current scientific.

Even when the phenomenon of Early Watercraft is discussed, it is exclusively in its horizontal understanding, and not as the root of shipbuilding evolution as it should be

regarded in longitudinal understanding how shipbuilding was developed.

Therefore, today we have a situation that terminology and typology in the field of Early Watercraft in the world is quite confused and vague. For example, we might only look at the *dugout canoe*, very frequently used term in the scientific literature which is actually a pleonasm: as we know *dugout* mean a hollow single tree log or trunk to construct a boat, but *canoe* was originally used to describe dug-out boats constructed by hollowing out a log, if it is true that the word came from the Arawakan Indians of the Caribbean islands word *kana:wa*. It is somehow same if we say *canoe canoe* or *dugout dugout*.

The task of the initiative is to comprehensively regulate this field of highly important human world culture heritage.

### Skin boats and some representative variations

Basic idea of skin boats in their different variations is to make a light skeleton construction from different materials as wicker, sticks, branches, reindeer antler, whalebones etc. and then cover it with animal skin as buffalo, cow, horse, yak, goat, pig etc.. All over the world it is possible to find skin boats in different main shapes as following: canoe, kayak, coracle, curragh, ku-dru or kowa. In order to present all dimensions of Early Watercraft invention phenomenon, it is necessary to include also inflated forms such as goat skin rafts and similar into the skin boats group.

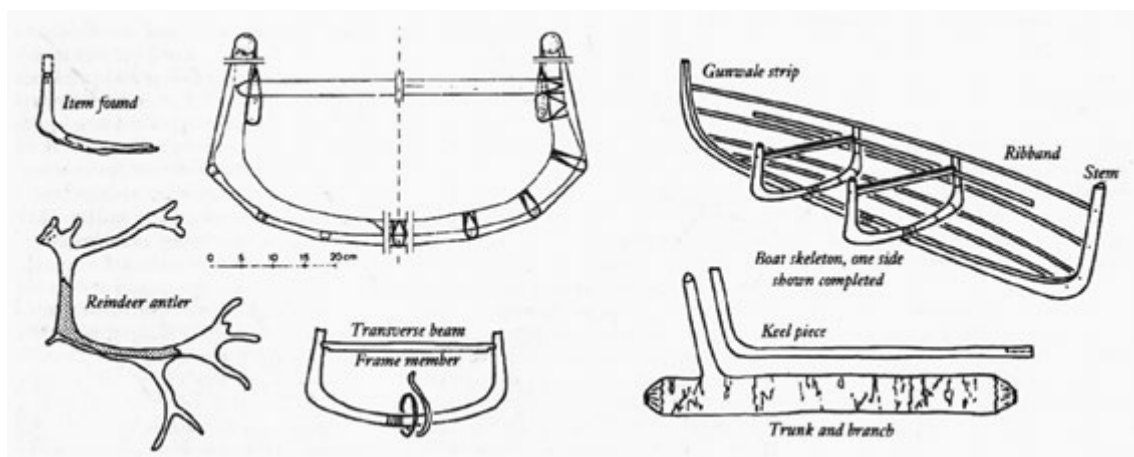

Figure 5: Skin boat: The oldest evidence could be the fragments of reindeer antler interpreted as boat frame from Husum, Germany, from 9<sup>th</sup> millenium BC mentioned by Detlev Elmers. Reconstruction was made by experts of German Maritime Museum. (Elmers, *The Beginnings of Boatbuilding in Central Europe*. In: Robert Gardiner, *Conway's History of the Ship. The Earliest Ships. The Evolution of Boats into Ships*, Conway, 2004, p. 12)





Figure 6: Skin boat: Moose Skin Boat on the Mackenzie River, North Western Territory, 1927. (Photography: J.B. Mawdsley; University of Saskatchewan, University Archives & Special Collections [On line] Available at: <<http://sain.scaa.sk.ca/items/index.php/moose-skin-boat-on-mackenzie-river-n-w-t;rad>> [29. May 2015])



Figure 7: Skin boat: A reconstruction of a first century AD British Curragh (a big coracle), made of wicker work and covered with 3 cow hides. It is capable of carrying 10 people. It was being paddled on the River Great Ouse at the 2008 Bedford River Festival. (Photography: Simon Speed [On line] Available at: <<http://en.wikipedia.org/wiki/Currach#/media/File:FloatingCurraghBedford.JPG>> [29. May 2015])



Figure 8: Skin boat: Modern Coracle from Kamalapuram, Karnataka, India. (Photography: by "thats" on Flickr [On line] Available at: <<https://www.flickr.com/photos/thats/853802281/>> [29. May 2015])



*Figure 9: Skin boat: Angyaqatak Bear Skin Boat made 2007 by Joe Spein and Alexie of Kwethluk, Alaska (Photography: Anchorage Museum Association Acquisition Fund, Anchorage Museum 2007, and Yupiit Piciryarait Cultural Center and Museum [On line] Available at: <<http://www.yupikscience.org/4riversspring/4-1.html>> [29. May 2015])*



*Figure 10: Skin boat: Typical ku-dru - Yak Skin Boat from Lake Yamdrock Tso, Tibet (Photographer of PhotographersDirect from Canada [On line] Available at: <<http://www.photographersdirect.com/buyers/stockphoto.asp?imageid=774063>> [29. May 2015])*



*Figure 11:* Skin boat: Special type of skin boat named Coracle from the Teifi River, Wales made from horse or ox skin (Unknown photographer; The museum collection of Cyngor Sir Ceredigion County Council [On line] Available at: <<https://pilgrim.ceredigion.gov.uk/index.cfm?articleid=1241>> [29. May 2015])



*Figure 12:* Skin boat: Kayak mostly made by seal skin and whalebone skeleton (Photography: Samuel Herbert Coward; McCord Museum, Montreal, Quebec [On line] Available at: <<http://www.mccord-museum.qc.ca/scripts/large.php?Lang=1&accessnumber=MP-1976.24.64&idImage=192484>> [29. May 2015])



*Figure 13:* Skin boat: Goat Skin Raft is basically made from 9 to 15 inflated, goat, lamb, or other similar inflated animal skin bound to each other with light wooden platform. This raft, photography taken in 1927, is from Karoun, Bakhtiari mountain, Bakhtiari province, Iran (Photography: Viktoria Mary Sackville-West; Anglo- Persian Oil Company [On line] Available at: <http://www.gutenberg.ca/ebooks/sackvillewest-twelvedays/sackvillewest-twelvedays-00-h-dir/sackvillewest-twelvedays-00-h.html#img-119>) [29. May 2015])



*Figure 14:* Skin boat: Traditional skin raft from Central Mountains, Shapotou, Zhongwei near Yellow river, China (Photography: Christine Tavernier [On line] Available at: <http://www.balladavelo.net/index.php?page=3&vpkv=56015&langid=2>) [29. May 2015])

### Bark boats and their' representative variations

Bark boats use similar philosophy of construction as boats do. Bark boats are made from light skeleton construction of different materials as wicker, sticks, branches, etc. and then covered with different tree bark's e.g. Birch, beech, willow as the most common, with specific features which allow to hide construction and allow navigation. As skin boats also bark could happen to be sewn together from more parts of bark. Mainly the shapes of bark boats are canoe-like but could be also coracle-like.



Figure 15: Bark boat: Type of Australian Bundle bark boat made from birch bark from Kepsey, New South Wales made in 1938 by Albert Woodlands (Photography: *left* Stuart Humphreys and *right* Andrew Frolows Australian National Maritime Museum [On line] Available at: <<http://australianmuseum.net.au/blogpost/science/tentative-chronology-of-indigenous-canoes-of-eastern-australia>> / <<http://australianmuseum.net.au/blogpost/science/boat-people-1#sthash.PuAl0sgc.dpuf>> [29. May 2015])



Figure 16: Bark boat: Type of Australian Sticked bark boat made from birch bark from South East Australia (Photography: Australian National Maritime Museum [On line] Available at: <<http://australianmuseum.net.au/blogpost/science/tentative-chronology-of-indigenous-canoes-of-eastern-australia>> [29. May 2015])



Figure 17: Bark boat: Typical Nord american Birchbark canoe named "ROB ROY" on Lake Chibougamau in northern Quebec, 1892 (Unknown photographer, Canadian Museum of Civilization [On line] Available at: <<https://beaverbarkcanoes.wordpress.com/the-birchbark-canoe-beaver-1922/>> [29. May 2015])



Figure 18: Bark boat: One of the South American beech bark boat - *Yagan anan*, boat of 'Alacaluf' from Punta Arenas Museum named **yeni** from end of 19<sup>th</sup> century (right). Drawing of *Yagan anan* from Dutch expedition of Jacob L'Hermite 1631 (left). (Unknown photographer, Museum of the Silesian Mission, Punta Arenas, Chile [On line] Available at: <<http://www.victory-cruises.com/yagancanoes.html>> [29. May 2015])



Figure 19: Bark boat: Coracle, also made from bark hide, as anglo-saxon name of shape type of watercraft which is known also in Tibet as *kowas* or *ku-dru* in Vietnam as *thung-chai* in Iraq as *guffa* and in India as *parisal*, *teppa* or *harigolu*. (Unknown photographer, [On line] Available at: <<http://kurungabaa.net/2010/11/02/corougle-corracle-curricle-and-coricle-the-coracle/>> [29. May 2015])

## Logboats and some representative variations

Basic construction of logboats stems from Greek *monoxylon*, more established as Dugout boat or canoe, its main feature being that its main feature being that is hollowed a tree trunk or log. All over the world and in many nations logboats are made from specific size trees that are available in local or regional environments. In Europe for example the most useful trees are oak, pine, fir, linden and spruce but also others as for example really rare beech. Logboat is made by carving or burning. Generally the logboats can be divided into single, self- expanded, multi- expanded, extended, expanded, double-outrigger and paired or multiple joined. Around the world there also exist some special types of logboats with local names for exact kind of shape and traditional craft processing e.g. Estonian *habjaas*, Philippinian *paraw*, Slovenian *čupa* and *drevak*, Japanese *maruta-bune* Tanzanian *ngalawa*, Polinesia *tepukei*, Sri Lankas *oruwa*, North Americans *canoe*, Botswanian *mekoro* Fijian *takia*, *camakau* & *drua*, Caroline Islandian *wa*, Marsh Arabians *tarada*, Guyanaian *korjaal*, Samoan *va'a-tele* and more.



Figure 20: Logboat: The oldest documented simple logboat on the world is c.3m long, made from pine. The logboat was found 1955 in Pesse, Netherlands. The original was preserved by freeze drying method and today is held by the Drents Museum in Assen. A reconstruction was made in 2001 by Jaap Beuker from Drents Museum and in 2011 a second replica was made by Charlie Timmermans *right* (Photography: Archive of Drents Museum [On line] Available at: <<http://www.bootvanpesse.nl/boot-pesse-replica.html>><<http://www.rtvdrenthe.nl/nieuws/hoogeveners-varen-met-replica-boomstamkano-van-pesse>> [29. May 2015]).



Figure 21: Logboat: One of the type of self- expanded logboat caled *habjaas* with inserted ribs from northern part's of Europe e.g. Finland, Estonia, Ukraina. Traditional manufacturing are maintained in Soomaa National Park in Estonia by Aivar Ruukel (Unknown photographer, archive of Soomaa National park [On line] Available at: <<http://www.flickrriver.com/photos/whltravel/sets/72157622828987707/>> [29. May 2015]).



Figure 22: Logboat: Special autochthonous construction of multi- extended logboat caled *drevak* which mean tree- boat, isolated in Notranjska region, Slovenia, perhaps with the roots in Roman period. It is made from fir with two part of logboat as chine-girders with one or two inserted bottom planks. Exposed in Technical Museum of Slovenia, Bistra (Photography: Miran Erič).



Figure 23: Logboat: *Left* Type of typical European 13<sup>rd</sup> century extended logboat with side planks coupled with the ribs from Kentmere, Cumbria discovered by David G. Wilson. (Photography: David Wilson; Seán McGrail, *Ancient Boats in North-West Europe. The Archaeology of Water Transport to AD 1500*, Longman AS 1998, p. 75, figure 6.15). *Right* Typical extended modern logboat use in Goa, India with high exposed constructional solution. Today extended logboats are often in combination with outriggers logboats specially for using on seas (Photography: Paul Wilson, Archive of Indigenous boat blog site of Bob Holtzman [On line] Available at: <[http://counter-agency24.rssing.com/chan-12927004/all\\_p1.html](http://counter-agency24.rssing.com/chan-12927004/all_p1.html)> [29. May 2015]).



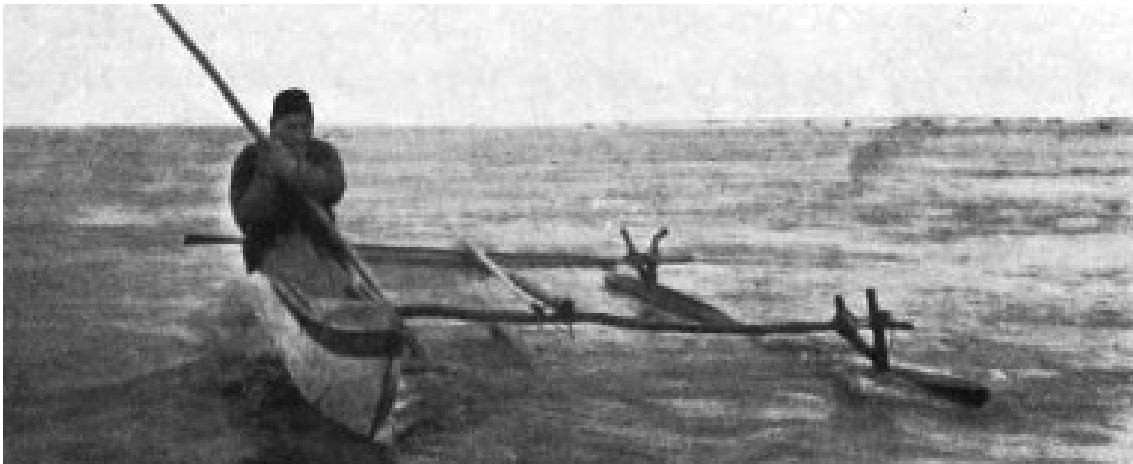

Figure 24: Logboat: Type of typical simple outrigger logboat from Cook Islands made from mango log and single outrigger. (Photography: Te Rangi Hiroa; Te Rangi Hiroa, *The material culture of the Cook Islands (Aitutaki) 1927*, p. 257 figure 223 [On line] Available at: <<http://nzetc.victoria.ac.nz/tm/scholarly/tei-BucMate-t1-body-d7.html#n287>> [29. May 2015]).



Figure 25: Logboat: The Maori's double outrigger logboat, *Henley canoe*, probably very old, found in the South Island and held by the Dominion Museum *top* (Photography: H. Hamilton; Elsdon Best, *The Maori Canoe: An account of various types of vessels used by the Maori of New Zealand in former times, with some descriptions of those of isles of the Pacific, and a brief account of the peopling of New Zealand*, 1976 p. 42 figure 7 [On line] Available at: <<http://nzetc.victoria.ac.nz/tm/scholarly/tei-BucMate-t1-body-d7.html#n287>> [29. May 2015]). Type of typical double outrigger logboat from Zanzibar *bottom*. (Unknown photographer, [On line] Available at: <<http://kickbike.blogspot.com/2013/06/eureka-pirogue-ing-it-with-bamboo.html>> [29. May 2015]);



Figure 26: Logboat: Type of untypical double outrigger fishing logboat called *čupa* from eastern coast of Trieste Gulf, Adriatic, made from fir log and special double outrigger (Slv.:*teslir*) for special kind of paddling with two at least 6m long oars and one 3m long auxiliary paddle. It was in use in Adriatic sea at least from Early Middle Ages. In 19<sup>th</sup> century Slovenes have fleet of more than 400 *čupa*'s (Photography: Petrichevich, Trieste, Slovene Ethnographic Museum [On line] Available at: <<http://www.etno-muzej.si/sl/cupa-plovilo-slovenskih-ribicev-0>> [29. May 2015]).

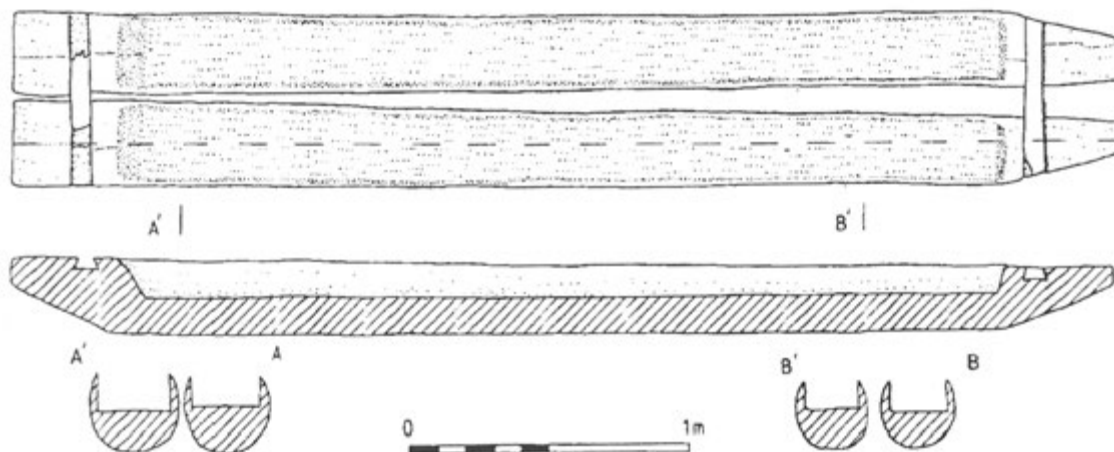
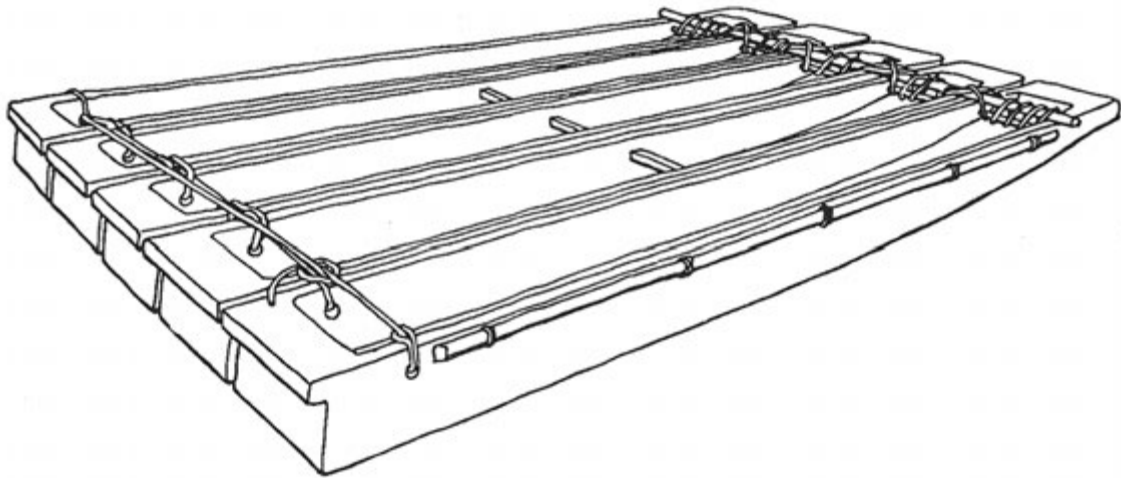
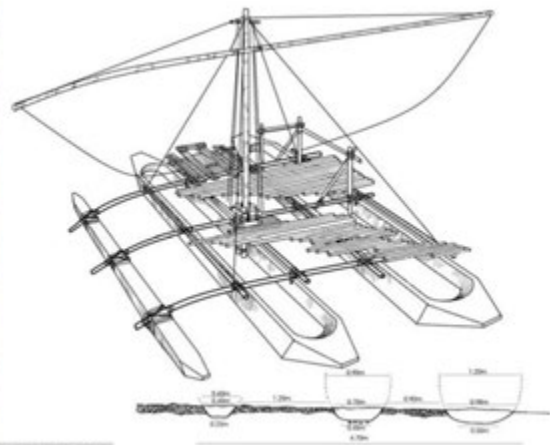

Figure 27: Logboat: Typical paired logboat from Bug river northern part of Poland with special Polish name *komjagami*, now placed in Sadowne Museum, *top* (Waldemar Ossowski, *Studia nad Lodziami jednopiennymi z obszaru Polski*, Prace Centralnego Muzeum Morskiego w Gdansk, tom XI 1999, p. 156, figure 140) Modern use of multi-hulled boat made with three logboats from Xekong River in Laos *bottom* (Photography: Ben Visbeek [On line] Available at: <<https://www.flickr.com/photos/81035653\spacefactor/@mN00/4414226741>> [29. May 2015]).



*Figure 28:* Logboat: Typical multi-hulled logboats was documented mainly on big European Rivers, that one combined with 5 logboats was used and documented on Dunajec River. This combined multiple logboats joining was use for ferrying. The frequent use of multi- hulled logboats for the needs of ferrying also showed the latest research in the area of Bavaria done by Lars Kröger, which illustrates the sophisticated technique of connecting boats together. (Waldemar Ossowski, *Studia nad Lodziami jednopiennymi z obszaru Polski*, Prace Centralnego Muzeum Morskiego w Gdansk, tom XI 1999, p. 156, figure 140).



*Figure 29:* Logboat: Discovery of evidence of paired logboats simple outrigger from 1700 BC find in Monmouth, South Wales, by archaeologist Stephen Clarke. (©Wales News Service, Dailymail, [On line] Available at: <<http://www.dailymail.co.uk/news/article-2441321/Monmouth-Worlds-oldest-boatyard-discovered-area-earmarked-housing-estate.html#ixzz3cr31omkx>> [29. May 2015]).

### Reed boats and some representative variations

Today Reed Boats are treated as the oldest known type of boat in the archaeological evidence. Main technological idea of constructing is to tie up tufts of grass in sufficiently large bundles that their capacity/buoyancy is large enough to be used by humans for navigation. This type of boat can be developed only in environments where suitable Reed (common name of grass-like plants that typically grow in wetland environments) is growing. Botanically, reeds belong to the *poales* order and the most common families are *Poaceae*, *Cyperaceae*, *Sparganiaceae*, *Typhaceae* and *Restionaceae*. The oldest evidence is known from petroglyphs in Gobustan National Historical Artistic Preserve in Azerbaijan date to Mesolithic Period, but the oldest known archaeological remains of possible reed boats could be bitumen slabs from Subiya site, on the northern shore of Kuwait Bay researched by dr. Robert Carter in 2001. Similarly to other Early Watercraft also reed boats also have many different local names occasionally given by their shape/frame or form.



Figure 30: Reed boat: very simple kayak-like shaped *Tankawa* papyrus boat paddled by two bladed paddle on Lake Tana, Ethiopia (Photography top: Brian J. McMorrow [On line] Available at: <<http://www.pbase.com/image/108955080>>) (Photography bottom: "Djib" by Flickr [On line] Available at: <<https://www.flickr.com/photos/99631178\spacefactor\@mN00/2645782736>> [29. May 2015]).



Figure 31: Reed boat: Typical canoe- like *woven tule* boat of indians tribes *Miwok*, *Ohlone* and *Pomo* from Northern California. Today is still in use on the Clear Lake Band of the Pomo. (Unknown photographer, ©Big-Valley.net [On line] Available at: <<https://mendonews.wordpress.com/2011/10/09/pomo-tule-boats-original-indiginous-seafaring-tule-boats/>> [29. May 2015]).



Figure 32: Reed boat: Typical *tutora* boat called *cabalito del totora* or *horse reed boat* from the Trojiljo district on northern Pacific coast of Peru. Coastal fishing. (Photography: Martin Garcia [On line] Available at: <<https://www.flickr.com/photos/martix/4321613099>> [29. May 2015]).



Figure 33: Reed boat: Lake Titicaca between Peru and Bolivia is one of the most known areas in the world where reed boats are still part of the everyday lives of the locals. The boats are all named *balsa* and vary in size from small to as large as 30m long. Typical *totora bullrush* small canoe-like boat from the Lake. (Photography: Andre Engels [On line] Available at: <[https://en.wikipedia.org/wiki/Reed\\_boat](https://en.wikipedia.org/wiki/Reed_boat)> [29. May 2015]).

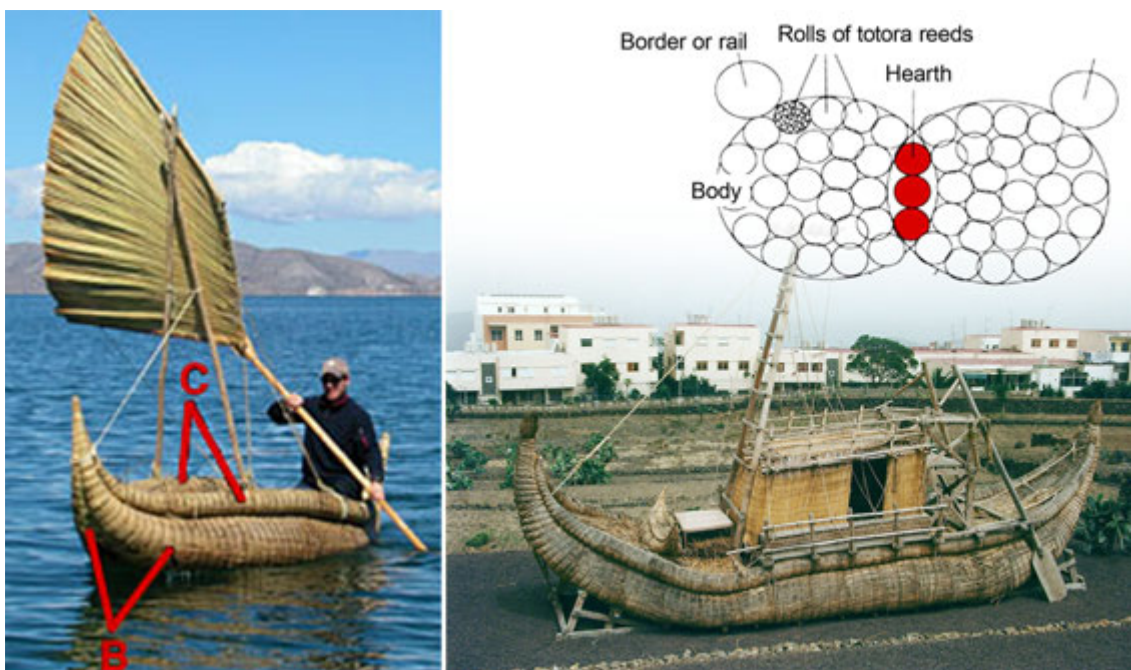

Figure 34: Reed boat: Thor Heyerdahl’s RA II reed boat with which he cross the Atlantic right (Photography: Pedro Ximenez [On line] Available at: <[https://en.wikipedia.org/wiki/Reed\\_boat](https://en.wikipedia.org/wiki/Reed_boat)> [29. May 2015]). Typical *totora bullrush* bigger sized boat from the Lake Titicaca, with the unique form/shape depends on special kind of constructing. The boat is made of about 50 *totora* reed rolls in two bodies lashed onto the heart and rails attached shown from study of Tiwanaku experimental project lead by Paul Harmon left and top (Photography and drawing: ©Paul Harmon [On line] Available at: <<http://interactive.archaeology.org/tiwanaku/project/experiment.html>> [29. May 2015]).



Figure 35: Reed boat: Typical *banana stalk* or *ambatch* (legume family african light tree with spongy wood) small boat from the Lake Baringo, Kenya. (Photography: ©Ariadne Van Zandbergen/Apa Publications [On line] Available at: <<http://www.insightguides.com/destinations/africa-middle-east/kenya/the-rift-valley-lakes/overview>> [29. May 2015]).



Figure 36: Reed boat: Reed boats were also recorded in Japan, in *Kojiki* from at list 8<sup>th</sup> century and presenting 2013 as experimental demonstration on Shirokita River in Osaka (Photography: ©The Asahi Shimbun [On line] Available at: <[http://ajw.asahi.com/article/behind\\_news/social\\_affairs/AJ201311110061](http://ajw.asahi.com/article/behind_news/social_affairs/AJ201311110061)> [29. May 2015]).



Figure 37: Reed boat: Typical Vietnamese *thung-chai* woven bamboo basket double ended boat from Da Nang region. (Photography: Ken Preston [On line] Available at: <<http://www.boatsandrice.com/wovenBamboo.html>> [29. May 2015]).



Figure 38: Reed boat: *Zaima* is an typical Al Hasans people woven *phragmites* grass basket double ended boat from Karmashiya in Hawizeh *Ma'dan* or *Marche Arab* in Iraq. Preparation of dry *phragmites* reeds for use in boat and house building on left and form of typical boat (Photography: Wilfred Patrick Thesiger [On line] Available at: <<https://www.pinterest.com/pin/350928995939783941/>> [29. May 2015]).



### Rafts and some representative variations

The basic idea of this special kind of Early Watercraft could probably be at the root of navigation invention. This is especially true, as this form of watercraft exists as non-human-made natural watercraft. The form's origins exist as non-manmade biological phenomenon of nature rafts, as put toward by Robert H. MacArthur and E. O. Wilson in their theory of insular biogeography<sup>6</sup> Under this theory such rafts consist of matted clumps of vegetation that have been swept off the dry land by a storm, wind, tsunami, tide, earthquake or similar events. They stay afloat by its natural buoyancy and can travel for hundreds, even thousands of miles by wind and streams and ultimately are destroyed by wave action and decomposition, or make landfall. Rafting events are important means of oceanic dispersal for non-flying animals. For small mammals, amphibians and reptiles in particular, but for many invertebrates as well, and finally humans too, such rafts of vegetation are often the only means by which they could reach and – if they are lucky – colonise oceanic islands.<sup>7</sup>



Figure 39: Raft: Even today some people use that the oldest version of natural reed raft such as the Sudanese, who created rafts from grass and reeds for use while trading down the Nile river (Photography: Erik Hersman [On line] Available at: <<http://whiteafrican.com/2010/11/27/finding-africas-innovators/>> [29. May 2015]). On the *bottom* are shown natural grass and reed rafts floating around Caribbean sea (Unknown photographer [On line] Available at: <<http://www.joana.ca/page43.php>> [29. May 2015]).

<sup>6</sup>Published as The Theory of Island Biogeography in 1967.

<sup>7</sup>In Wikipedia: Raft. [on line] <<http://en.wikipedia.org/wiki/Raft>>



Figure 40: Raft: Typical *mudhif* floating basket homes or rafts or reed islands are traditional housing in *Ma'dan* in River Tigris catchment area in Iraq. It is not unique in the world while similar tradition is also recorded on Titicaca Lake in Peru as well as Aztec tradition of both housing and gardening on floating reed rafts big enough to be called floating islands. (Photography: Vanessa MessyNessy [On line] Available at: <<http://www.messynessychic.com/2014/11/12/the-floating-basket-homes-of-iraq-a-paradise-almost-lost-to-saddam/>> [29. May 2015]).



Figure 41: Raft: Typical aboriginal *koola* mangroova tree raft from Georg Water in Western Australia from 1916. It is believed that maybe rafts were used 60 thousand years ago to colonise Australia from nearest Indonesian islands. (Photography: Herbert Basedow [On line] Available at: <[http://www.nma.gov.au/engage-learn/schools/classroom-resources/activities/basedow\\_photographs](http://www.nma.gov.au/engage-learn/schools/classroom-resources/activities/basedow_photographs)> [29. May 2015]).



Figure 42: Raft: Typical Tamil's *kattumaram* raft made from fibrous palm tree is still in use on the coast of South India specially on the beaches of Tamil Nadu, Mamallapuram (Photography: Peter Malakoff [On line] Available at: <<http://www.petermalakoff.com/Tusami/Tsunami.html>> [29. May 2015]).



Figure 43: Raft: On the North eastern part of Peru, rafts are typically made from the balsa tree. The well-known story of the Thor Heyerdahl *Kon-Tiki* expedition illustrates that the Pacific Ocean could be crossed from South America to Polynesian islands with a larger balsa tree raft. (Photography: Melissa Merino [On line] Available at: <<http://archivo.larepublica.pe/03-03-2013/piura-la-isla-foca-alberga-una-fauna-incomparable#!foto4>> [29. May 2015]).



*Figure 44:* Raft: Because of the good characteristics of bamboo stalks in the areas of bamboo habitat it is common to use them for making rafts. Bamboo rafts are widespread in all parts of the world where bamboo naturally grows. Typical type of raft from Irrawaddy river near Bahalminhtin Bridge near the town of Myitkyina in the northern Myanmar (Photography: ©Reuters/Soe Zeya Tun [On line] Available at: <<http://www.reuters.com/article/2011/04/21/us-china-dams-idUSTRE73J1CS20110421>> [29. May 2015]).



*Figure 45:* Raft: Special kind of traditional cormorant fishing on Li River in Yangshou, Guilin, Guangxi Province, China (Photography: by "123gabyn" [On line] Available at: <<http://www.viator.com/photos/Guilin-tours/Li-River-Cruise-Full-Day-Tour-of-Guilin-and-Yangshuo/2228582>> [29. May 2015]).



Figure 46: Raft: Torres Strait islanders on a bamboo raft, 1906; Reference: Neg no. 6617. Call no. GN 671.T6 "To get from mainland Asia to Near Oceania at least 10 water crossings of 10–100 kilometres were required. Somehow people crossed these stretches of water, but no remnants of their vessels have been found. Around 50,000–25,000 BC knives had been invented but adzes, which could hollow out logs to make canoes, had not. Although it is speculation, it seems likely that the giant bamboo that grows in the region was lashed together to form rafts. Whatever form these early vessels took, they were seaworthy enough to enable people to island-hop as far east as the Solomon Islands in Near Oceania" (Geoff Irwin. 'Pacific migrations - Ancient voyaging in Near Oceania', Te Ara - the Encyclopedia of New Zealand, updated 15-Nov-12 [On line] Available at: <<http://www.teara.govt.nz/en/photograph/1764/torres-strait-islanders-on-a-bamboo-raft-1906>> [29. May 2015]).

### Plank boats and some representative variations

It is difficult to decide if plank boats, even if they are technologically simple or small, can be considered to be pivotal to the invention of navigation in a similar way to which rafts and other more basic use of logs, barks, skins boats etc are considered to have influenced the early stages of navigation. The more basic style of vessels, by their nature, don't require many as sophisticated tools to prepare them for navigation for example. According to some, plank boats are already an early phase of development of shipbuilding. Before metal tools were widely available, it was much harder to make boat by planks. As it currently stands, the oldest archaeological evidence for plank boats is the funerary royal solar Abydos boats from Egypt, the oldest one, Den Solar Ship dating to c.2935 BC. These Egyptian vessels were built by highly developed skills and techniques illustrating that this technology must have existed for a significant time before this. Equally impressive are the beautifully designed and sophisticatedly constructed North European Bronze Age plank boats from Dover and Ferriby.

To produce this type of boat, the known techniques and their versions can roughly be classified into shell- or frame first boat construction, clinker and carvel and plank joining by peg mortise and tenon and sewn or lashed both clinker and carvel types. Therefore it can be concluded that the beginnings of plank boat building can be much older.



Figure 47: Plank boat: Dover boat was constructed of oak planks, stitched together with yew withies and also fixed together with wooden wedges (Top left: Paddling a half scale replica, top right: Excavation in 1992 and bottom: Replica reconstructing 2013 [On line] Available at: <<http://www.canterburytrust.co.uk/trust-blog/>> [29. May 2015]).



Figure 48: Plank boat: Typical Three- plank boat *sampan* from Mekong river in Laos. Boat is flat bottomed, with shovel ends, flaring sides, and quite long for their width. It is joined and stitched with rattan or bamboo strips, which in later times were replaced by bamboo nails or iron nails. A further improvement was the use of tenoning. (Photography: Ken Preston [On line] Available at: <<http://www.boatsandrice.com/Lmekong.html>> [29. May 2015]).



Figure 49: Plank boat: Typical Vietnamese Five- plank boat from Central coast and Ron river. Boat is flat bottomed, with shovel ends, flaring sides, and quite long for their width. (Photography: Ken Preston [On line] Available at: <<http://www.boatsandrice.com/cVN.html>> [29. May 2015]).



Figure 50: Plank boat: Typical plank boat *sabani* from fishing port Itoman in Okinawa. Boat is "V" formed chine and fastened with hardwood butterfly keys *huundu* (Photography: Douglas Brooks [On line] Available at: <<http://blog.douglasbrooksboatbuilding.com/2014/07/okinawa.html>> [29. May 2015]).



Figure 51: Plank boat: Typical Indian plank boat '*Elye'wun*' of Chumash people from south California. Boat is "V" formed chine (Photography: ©Chumash Maritime Association [On line] Available at: <<http://www.chumashmaritime.org/Home.html>> [29. May 2015]).





*Figure 52:* Plank boat: Slovenian farmer's plank boat, photography is from 1956 showing farmers transport hay, from river Krka basin in South East part of Slovenia. Boat is flat bottomed and is in shape which is dispersed on rivers in Central Europe (Photography: Boris Orel@Slovene Ethnographic Museum [On line] Available at: <<http://www.etno-muzej.si/en/spletne-zbirke/coln-jadrnica/f0000013311>> [29. May 2015]).



*Figure 53:* Plank boat: Typical flat bottom fishing plank boat from lake Tanganyika. (Photography: Scott Brooks @Slovene Ethnographic Museum [On line] Available at: <<http://scottsnxtadventure.blogspot.com/2013/02/some-of-lake-tanganyikas-fineest.html>> [29. May 2015]).

## Other

Of course, the Early Watercraft themselves are linked to a lot of additional equipment such as propulsion devices e.g. paddles, oars and rod/pole for watercraft moving, occasionally sails, other added equipment as ropes and then there are the smaller items, toys, depicting boats. Finally a lot of prehistoric descriptions of Early Watercraft e.g. petroglyph's, stone art, papyrus can also be considered as sources of information.etc. It is also the part of the interest of study of navigation invention.



Figure 54: Several times it happens that also a paddle is detected when logboat is discovered. It was the case when the logboat *Krtina I*, SI-04 from 2<sup>nd</sup> century was excavated on *Ljubljansko barje* near Ljubljana, Slovenija (Photography: Miran Erič. In: Erič, M, Archaeology of Ljubljansko barje: Ships, Logboats, Ship toys and paddles, Reports of Underwater Archaeology Division, vol. 26, 2008, p. 19, fig. 21 [On line] Available at: <[https://www.academia.edu/3503344/\\_SPA\\_26\\_Archaeology\\_of\\_Ljubljansko\\_barje\\_Ships\\_Logboats\\_Ship\\_toy\\_and\\_paddles\\_Evidence\\_of\\_vessels\\_detected\\_on\\_Ljubljansko\\_Barje](https://www.academia.edu/3503344/_SPA_26_Archaeology_of_Ljubljansko_barje_Ships_Logboats_Ship_toy_and_paddles_Evidence_of_vessels_detected_on_Ljubljansko_Barje)> [29. May 2015]).



Figure 55: Contemporary use of traditional plank boats *pinasse* by Bamako's "sand man" of Mali propelled by bamboo poles. (Photography: Kyle Miljof [On line] Available at: <<http://africageographic.com/blog/the-sand-men-of-mali/>> [29. May 2015]).



Figure 56: To navigate Early Watercraft the use of wind power was also common. Typical Australian aboriginal Oceanic lateen- like sail use on a logboat. (Photography: ©Gunter Senft/MPI for Psycholinguistic [On line] Available at: <<http://www.sci-news.com/genetics/article00821.html>> [29. May 2015]).



*Figure 57:* Some special forms of using water and possibility of floating, which could not be understood as navigation, but is in any way important for migration. These can also be the matter of different kind of early floating bridges. Bamboo floating bridge on River Xam near Xam Tai in jungle of Nam Xam Nature Reserve in western Houaphon in Laos (Photography: Josh Hirschstein ©Travel Ventures [On line] Available at: <<http://hilltribeart.com/wordpress/?p=406>> [29. May 2015]).



*Figure 58:* Around the world is also registered a lot of toys showing the Early Watercraft and this is for sure also the topic of researching. This is a wooden replica of an ocean-going Viking longboat that was discovered during the National Museum of Ireland's excavations at Winetavern Street, Dublin. Most likely a toy, the vessel measures approximately 37 cm in length by a maximum of 8.5 cm in width. Originally the boat would have had a mast and a sail, as evidenced by the presence of a mast-step and shroud holes for securing the rigging. Another hole at the end of the vessel was probably used to attach a stern rudder (Photography: Christensen 1988, p. 20; In: Christensen, A. 1988 'Ship Graffiti and Models'. In Patrick F. Wallace (ed.) *Miscellanea 1, Medieval Dublin Excavations, 1962-81*. Royal Irish Academy, Dublin, pp. 13-26 [On line] Available at: <<http://irisharchaeology.ie/2013/03/a-viking-age-toy-boat-from-dublin/>> [29. May 2015]).



*Figure 59:* Descriptions: The reed boat petroglyph (Boat No. 29 cg) in Qobustan National Historical Artistic Preserve in Azerbaijan date to Mesolithic Period. A boat with a sun sign on its bow. There are 23 vertical lines on the hull, presumably representing people. (Farajova Malahat, Rock Art of Azerbaijan. Baku, 2009 [On line] Available at: <<http://gobustan.si.edu/timeline>>; Photography: Bruno Girin [On line] Available at: <<https://www.flickr.com/photos/16405999\spacefactor/@mN00/19891161>> [29. May 2015]).

## **Strategic objectives**

The Initiative of **Early Watercraft - A global perspective of invention and development** is an abstract movement comprising a worldwide network of dispersed scientific researchers, institutes, heritage promoters and museums, heritage parks, enthusiastic amateurs, local communities and other members with a strong desire to explore the paramount importance of the invention of Early Watercraft and its consequences. Ambassadors confers the status of an Initiative not to territory but to mind, spirit and the extraordinary importance of the development of mankind and one of the oldest and most important inventions of mankind.

The Ambassadors is an Initiative in time, an Initiative without territory and national borders. The right to Initiative belongs to the institutions and people around the world of different religions, races, nationalities, sexes and beliefs. The right to be a member of Initiative is acquired through the support of Initiative and activities in the field of the topic.

While the invention of Watercraft is an unexplored phenomenon in time and space the Initiative is conceived as a inherently transnational formation which has no physical territory and which is not to be identified with any existing national state.

## **Short-term objectives**

Short-term objectives concern the activities of Ambassadors of the Initiative "Early Watercraft - A global perspective of invention and development" which will be realised in the next half of year after the meeting in Vrhnika in April 2015.

Ambassadors are responsible for the preparation of the Minutes' of the meeting in one month's time after the meeting.

Chosen Ambassadors will prepare the Proposal of the Initiative. This should be done in the next few weeks but no later than the second half May or beginning of June 2015.

Some of Ambassadors will visit First international regatta of prehistoric logboats in Biel/Bienne organised by the Neues Museum Biel, and the ArchaeoConcept in the end of May 2015. They will participate in international round table on experimental archaeology with the topic of logboats and other prehistoric wooden objects building. Their task at the round- table is to promote and disseminate the importance of the Initiative. As Cynthia Dunning, vice-president of Executive Committee of International Committee on

Archaeological Heritage Management of ICOMOS, is one of the Ambassadors of Initiative, they will discuss the organisational form of the Initiative and possibilities to prepare the local, international, European and global projects within the context of Initiative in order to provide funding for the stable operation.

In next few months promotion of the Initiative will start using all free publicly available social networks (Facebook page "Early Watercraft – A global perspective of invention and development" is active from Friday 24<sup>th</sup> April 2015), and professional networks by WWW Official Initiative website will be created. Immediately (list exist from Friday 24<sup>th</sup> of April 2015) information sharing will start with closed address list of 20 Ambassadors (Ambassadors level: mail address of list is ewa@list.arnes.si). All Ambassadors are committed to prepare a list of colleagues all around the world and send them the Proposal of Initiative and invite them to join the Initiative. Address list should be prepared until middle of June 2015. The list will be open for all new interested researchers.

Some of Ambassadors will do the local (compare different country) and international law review to find the best location and legal form for the headquarters of the Initiative, which should be as much as possible relieved of local, regional and global political, ideological and religious interference. After discussion on the meeting, so far, it appears that NGO (Non-Governmental Organisation) would be the most appropriate form. It is just the question of country which would offer the best conditions for headquarters.

Promotional poster will be prepared (finished 20<sup>th</sup> May 2015) for use in different countries to promote the Initiative but the main presentation opportunity of promoting the Initiative will be at the upcoming International Symposium on Boat and Ship Archaeology - ISBSA 14 "Change and continuity in shipbuilding" organised by National Maritime Museum in Gdansk between 21<sup>st</sup> to 25<sup>th</sup> September 2015 in Gdansk. For the first time in the research of the history of Shipbuilding it will happen that Early Watercraft get special session "Bark, skin, logboats" with chairmen Ronald Bockius and Waldemar Ossowski, the Ambassadors of the Initiative. The Initiative's poster will also be included in to the small local permanent posters exhibition "Underwater Heritage in Slovenia: Selected Research 1995-2012" by authors Andrej Gaspari and Miran Erič, also the Ambassadors of the Initiative.

### Mid- and Long-term objectives

Goals in the future midterm period of next two to three year and long-term period for the Ambassadors and subsequently connected members of the Initiative should be:

Establishment of the best type of organisational framework for "Early Watercraft – A global perspective of invention and development". Purpose of the Initiative is to include:

- a. professional individual researchers and scientists,
- b. professional Institutions, Universities, Museums, Nature and Cultural parks,
- c. local and regional communities where the Early Watercraft are still in use for economical and daily live purpose and
- d. local communities and individual enthusiasts where the Early Watercraft, their reconstructions and modern redesigned forms, are main interest for their contemporary educational, promotional, sports, and sustainable and cultural tourism purposes.

Indicative's starting point for the organisation is to include all continents i.e. all world without any daily geopolitical – local, regional, international and global – religious, ideological, economical, or any other influence. Most likely it is that the most appropriate form in our case will be "**Non-Governmental Organisation**".

Scientific point, which must be the guiding idea and efforts of Initiative, must include the widest angle of views of research interests. Early Watercraft should be studied from different scientific sides: archaeology, anthropology, history, ethnology, art, geology, paleo- environmental, physic, biology, geology, philosophy, computer and information, technology, sociology, etc. The most important long-term task of this initiative is to establish a frame for a permanently operating group of scientific researchers with the goal to research one of the most important inventions of mankind and its early development related in to the **World Research Institute for invention and early development of Early Watercraft** with the following important goal.

To create a global **integrated meta database** of all archaeological discoveries, anthropological and ethnological documentation on traditional watercraft, reconstructions and copies of discovered watercraft which arise all over the world through the revival of the tradition of manufacturing.

To establish conditions for the education and promotion of invention of Early Watercraft through an **Early Watercraft Heritage Network** of interconnected museums, heritology parks, touristic, sporting and other organizations responsible for protection of



cultural heritage as well as amateurs initiative in reviving the tradition. All efforts should be directed towards the completely new promotional format that would work uniformly across the world and in the local, regional and global level with the units all around the world.

Contents preparation for the various calls for projects which may be targeted in different fields like, science, culture, heritage protection, IT development, rural community development, sustainable tourism, alternative sports, traffic and transport, art, etc. Examine the possibilities of how to include our contents under the UNESCO auspice.

Together with the web page an **EWA - International Journal for Early Watercraft Researching** should be build up. From the beginning the Journal will be in function just as electronic version. If the purpose of Journal will be proven as necessary and useful (and there is not any doubt), we will contact one of the existing scientific publishers (Elsevier, Springer,...) to include the Journal into its' editions. Journal should be organised with **i.** journal selected peer- review, **ii.** self selected peer- review, and **iii.** non- review levelling which provides us a wider net of availability authors.

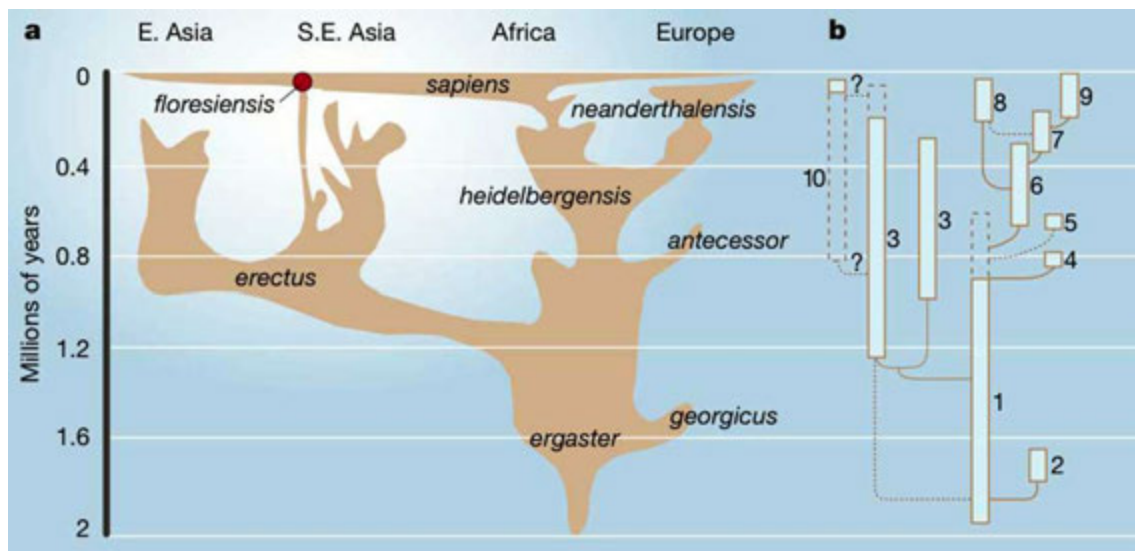

Figure 60: One of the spatial factors of controlled scientific research could be helped by understanding the evolution of hominid combined with past climate change and geological moves of continents. (Cooper, Alan, and C. B. Stringer. "Did the Denisovans Cross Wallace's Line?." *Science* 342.6156 (2013): 321-323 [On line] Available at: <<http://peaceandjustice.freeforums.net/thread/10/genomic-data-reveal-complex-humans?page=14>> [29. May 2015]).

## Spatial factors of mission and operation

Quidquid futurum est summum, ab imo nascitur

---

— *Latin proverb*

So far, it is completely unexplored when, where and which group of the people in the past and in the evolution of mankind was the first to established the benefits of using the world's water network. Therefore the task of the Initiative is promotion of scientific research, education campaigns and promotions across the globe. It is certainly necessary to look at the known background data on the evolution and migration models, which make speculation possible, where and when the Watercraft would need be used by *Homo Erectus* prior to 800k years.

## Research methods and techniques

Necesse est, ut non modo casus eventusque rerum, sed ratio etiam  
causaeque noscantur

---

— *Latin proverb*

To develop ideas and to deepen the research on the phenomenon and its development, certainly it necessary to use all the research methods and techniques from a variety of research disciplines, which should help to highlight the scientific research, education, promotion and at the end of the use and maintenance of traditional knowledge all over the world. This is the only human invention that has not changed throughout the history of mankind and is still in use in its original form.

## Forms and scope of activities

Part of the activities must be paid on the Symbolic Level after performed the fulfillment of a greater extent of above stated objectives. The GEWRI has a Double Task: The Cultural Centre of European Space Technologies (CCEST) focuses its activities on the programme for culturalization of space, proceeding from the point where the Fallen Astronaut ended. The basic idea of the program is to enable artists and scientists to engage in varied theme research into human activities in space and to create an in depth environment for modern and historic intercultural scientific research. At the symbolic level, the logboat is the prime human invention; it has greatly contributed to symbolic liberation of man's mind and the understanding that, in the physical sense, the water network system of

the earth equals its communication and transportation network. Until the 19<sup>th</sup> century transportation by water had been the fastest type of transport. It had enabled man to explore the unknown. At the same time, it was an implement whose increased carrying capacity greatly exceeded man's physical abilities.

In fact, only three times in human history has man succeeded in leaving his natural habitat – dry land – and penetrating into other dimensions. On each occasion a special 'apparatus' was required: first the boat, then the aircraft and finally the rocket and space capsule.

---

— Detlev Elmers

In the future, space research will reveal that space is likewise intertwined with a communication and transportation network, and is eagerly awaiting the invention of a new (pre)historic vessel to carry us into the unknown. Therefore, the CCEST programs for culturalization of space should examine possibilities for realisation of two symbolic actions: sending a copy of the world's oldest logboat, equipped with the most up-to-date measuring instruments, on the journey towards the sun, in gratitude for the gift of life; and sending another logboat in towards the edge of the universe, into the great unknown—like the symbolic semantic message carried by Pioneer 10 to possible extraterrestrial cultures outside our solar system.

### Scientific research

GLOBAL EARLY WATERCRAFT RESEARCH INSTITUTE (GEWRI) UNDER THE AUSPICES OF UNESCO:

Since the *Ljubljansko barje* with its high density of finds is a region that has greatly contributed to the development of the idea, one of the seats of the global organisation could be in Slovenia (with the departments on all continents around the world), whereas the data and knowledge (on Early Watercraft with all local and regional variations) could, and should be collected on all continents. The premises would be in the immediate vicinity of the Technical Museum in Bistra. It would be equipped with interactive presentation systems, based on holograms and other cutting-edge information technologies. This would in future allow, for instance, in future development of an interactive rowing in so called, I-pool (pool managed by using artificial intelligence) and detailed virtual observation of Early Watercraft from all around the world. The scientific research work carried out there would support other Units and Collections in this Heritage Park. The



Figure 61: Small replica of Yverdon boat. As a sample also the Museum für Antike Schifffahrt RGMZ from Mainz as a part of them program take also a lot of researching projects to understand Early Watercraft developing and navigation (Photography: ©Museum für Antike Schifffahrt, Mainz [Online] Available at: <<http://www.livius.org/00switzerland.html>> [29. May 2015]).

GEWRI would also be involved in experimental production of vessels.

#### COLLECTION OF ORIGINAL VESSELS:

The Early Watercraft that have been preserved are being kept either in museum collections or are remaining, thanks to the researchers cognizance *in situ*. Some of them, of course we are talking about those due to spatial interventions, which can not be avoided and must be removed to protect, should be presented to the general public for educational purposes.

#### Database/Network

Tempora cuncta solent homines spectare saqaces, ad praesensa  
solum respicit insipiens

— *Latin proverb*

All around the world exists a lot of different databases with a lot of information about the phenomenon of Early Watercraft. Just in Europe each country has their own separate databases about the discovery of logboats and other Early Watercraft with more or less similar structure of data.

The situation is similar with collecting archaeological, anthropological and ethnological evidence of simple watercraft all around the world.. There is also a huge pile of visual

information such as photographs, drawings, video and other contemporary possibility as 3D modelling also. But all this important evidence is dispersed all around the world and lack of recognition of the the incredible significance of the invention of Early Watercraft is the result. It should therefore be the most important task of this Initiative to establish an up-to-date systematically organised and structured worldwide single repository database covering all the incidence of this phenomenon that allows easy retrieval, updating, analysis, and output of data. This data should be in the form of graphics, reports, scripts, tables, text, etc., representing almost every kind of information. The database should include the most complete information on the phenomenon, including the transfer of existing articles and the oldest descriptions and their automatic conversion from 2D drawings to 3D models, automatic classification of entered data and many other possibilities including easy data entry and specially really easy public accessibility. It should allow the content of all forms of information, both textual and visual.



Figure 62: Important contemporary input to scientific research of Early Watercraft is new computer technology and it's extremely advanced and affordable measuring devices and options for 3D data capture to enable full accurate documentation of heritage of Early Watercraft. 3D capturing of extended logboat *Notranjski drevák* in Bistra, Slovenia (Photography: Janez Rupnik [Online] Available at: <<https://www.facebook.com/photo.php?fbid=10204400478828142&set=o.1661713817382855&type=3&theater>> [29. May 2015]).

**Knowledge exchange: organisation, scientific conferences, journal, web based public communication**

Every choice affects our lives today. We can understand where our story begun and how we are connected. It gives us a spark to choose the right path for our descendants and make our lives worthy of remembering.

---

— *Unknown*

It is also recognised as one of the important tasks of the Initiative. The process of knowledge exchange about importance of invention of Early Watercraft for mankind evolution and development is vital. This is a process which brings together academic researchers, users of knowledge and wider groups and communities to exchange ideas, evidence and expertise. Within the Initiative the main target groups for activity and the overall aim is to contribute to heritage understanding with the cultural and environmental benefits to society. In practice, all knowledge exchange engages across these audiences. Knowledge exchanging should include worldwide organisation probably under auspice of UNESCO (ICOM/ICOMOS), Early Watercraft instructors and experts board, scientific research institute network with the institutional and personal members from all around the world, network of heritage parks around the world, scientific conferences, heritage public festivals, journals and web based communications on different levels including single worldwide meta- database of Early Watercraft knowledge.

**Original Early Watercraft Conservation and Protection**

Today's practice in conservation of waterlogged wooden finds by means of polyethylene glycol or melamine is unfortunately deficient and unsatisfactory. In order to meet all requirements for protection, safeguarding and presentation of a selection of original vessels, we should investigate the possibilities for development of, so called, I-aquariums—cells with controlled, biologically steered hydrological climate and the possibility for indoor and outdoor display of chosen artifacts. This idea should be put into practice by an interdisciplinary team of specialists in woodworking, microbiology, hydrology, mechanical engineering, computer science etc. It is based on prevention of decomposition of wood in the course of physical, microbiological and chemical processes. This could be achieved with the help of cutting-edge technology, effecting powerful water currents, cavitation systems, a thermo-hydrological balance and carefully implemented adjustments in microbiological balancing of water plants and animals.

## Promotion, Popularisation and Education

### COLLECTION OF COPIES AND RECONSTRUCTIONS OF THE OLDEST, AUTOCHTHONOUS AND INDIGENOUS WATERCRAFT:

The collection could expand gradually, from year to year. The beginning could be marked by the reconstruction of the oldest one: Pesse canoe from the Netherlands or any regionally more interesting logboat. New copies or reconstructions of prehistoric logboats could be made at the annual festivals every year. In a couple of years dozens of logboats would be carved and fabricated all around the world. These collections would be managed by the local population of the countries that have embraced the idea of the global heritage park. These new boats could be used for organisation of educational trips or "logboat treks". In Slovenia they could, for instance, sail between Bistra, Vrhnika and Ljubljana. Each logboat would have a berth at Vrhnika, Podpeč and Ljubljana. The berths would be equipped with the data about the boat, its discovery and the circumstances at the time when it was in use. Along the navigation route there could be stations with accommodation facilities. All logboats in the system would be equipped with high-tech navigation devices, enabling interactive "real-time" monitoring from all over the world. One of the thematic collections in the heritage park would contain originals, copies and reconstructions of typical watercraft of around the world.

### COLLECTION OF PREHISTORIC AND INDIGENOUS WATERCRAFT OF LOCAL AND REGIONAL IMPORTANCE:

At least three stories with local colourful character from Slovenia can be presented:

1. Presentation of early Roman barges of the North Mediterranean shipbuilding tradition (Lipe, Sinja Gorica); a minor permanent exhibition at the Information Centre – presentation of the vessels Arles Rhone 2 from Marseilles, Yverdon 1 and Bevaix from Lake Neuchâtel and Lipe; fabrication of the vessels from Sinja Gorica and Lipe – real size reconstructions intended for tourist boat trips, cultural events and renting.
2. Exhibition of the *čupa* – typical Slovenian north Adriatic fishing logboat and the fishing fleet. It is little known that in the 18<sup>th</sup> and 19<sup>th</sup> centuries Slovenes used to have the biggest fishing fleet of more than 400 logboats, so called *čupa*, in the Gulf of Trieste. The collection would pay tribute to this fishing fleet.
3. Collection of expanded logboats *Notranjski drevak*, typical of the Notranjska region: This type of logboat, so called *Drevak* was used by local people on Karstic region on *Cerkniško jezero*, *Planinsko polje*, *Loška dolina* and the *Ljubljansko barje* during the last centuries. The



*Figure 63:* One of the very important activities of the Initiative will be also support, integration, promotion and encourage the efforts of local communities around the world to maintain the tradition of making Early Watercraft and through various educational festivals promote the knowledge and importance of early vessels. In May 2015 Neues Museum Biel and ArchaeoConcept organise the first International Logboat Regatta with five replicas of ancient logboats from around the Alps (Photography: Niall Gregory).

latest studies of ship construction in Sinja Gorica indicate that this shipbuilding tradition may have also originated in Slovenia and not in the river Po valley, the alleged home of this type of boat. One specimen (5,5 m long) is preserved by the Technical Museum of Slovenia, and another (12 m long) in the Kravanje House in Cerknica. These boats have, interestingly, almost identical construction as the vessels on the Suwa Lake properties, so called *maruta-bune*, south of Nagano in Japan, which have also been in use for several hundreds of years (WS: Kagami blog by Stephen Robertson: The Abandoned Skiff; Miyashita, H.: Ancient Ships of Japan. Master Thesis Texas A&M University)

### **Museums, heritage parks, tourism and sports – sustainable and ecological use**

Thematic Paths, for example on the *Ljubljansko barje* and around the world where local communities want to put into life Early Watercraft Thematic Park: all sites where logboats were found in the Marshes, or regions where other kind of Early watercraft are still in daily use, should be equipped with a "smart" boards with a description of individual finds (on Barje c.70 boards). Advanced computer technology would allow virtual visits of these locations. The boards could be linked to a computer game devised for this purpose, for instance, "Find the Early Watercraft discovery location". In addition, a prize winning (mobile stamp application) system could be introduced for visits of Early Watercraft sites.



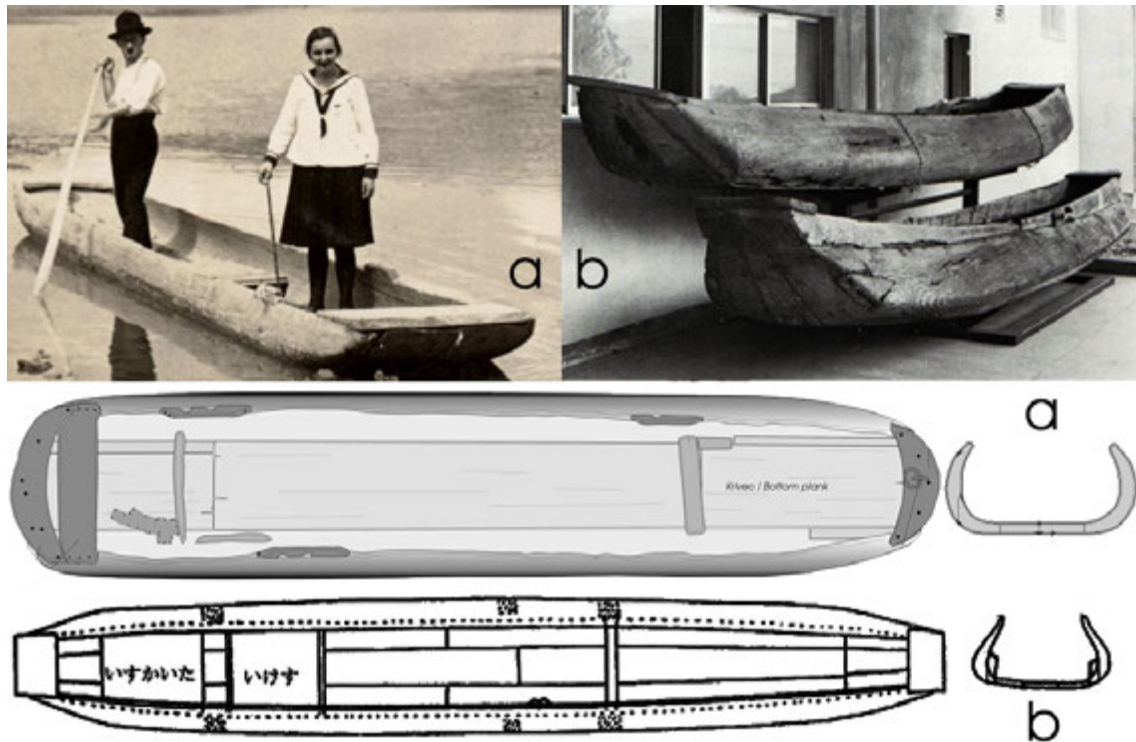

Figure 64: Intriguing story of expanded logboat similarity of typical construction details between **a.** *Notranjski drevák* from Slovenia (picture taken in 1927) and expanded logboat **b.** *Suwako maruta-bune* 諏訪湖まるた舟 from Lake Suwa near Nagano, Japan (Photographer of **a.**: Stanko Ribnikar; plan drawing: Miran Erič [On line] Available at: <<http://stareslike.cerknica.org/2010/06/22/1930-jezero%C2%A0usiha-v-resetu/>> and photography of **b.**: SBSI, ed. 2003: 132 ©Lake Suwa Museum and Akahiko Memorial Museum. SBSI (Shimosuwa-machi Bunkazai Senmon Inka), ed. 2003 Shimosuwa-machi no bunkazai 下諏訪町の文化財 – Shimosuwa's Cultural Heritage (Rev. edition). Shimosuwa: Shimosuwa-machi Kyōiku Inka <[http://blog.sdrobertson.org/2013/02/the-abandoned\\_22.html](http://blog.sdrobertson.org/2013/02/the-abandoned_22.html)> [29. May 2015]).

The "prizes" could be used for renting Early Watercraft for "country trek" in all parks around the world with available heritological facilities.

Festivals should also be part of promotion and education and other promotion activities organised by worldwide team. They would include events for promoting Early Watercraft, e.g. "Logboat sailing race", attended by celebrities, athletes, artists, scientists etc. and accompanied by festivities. As example a 20 km long racing route could, for instance, be set on the Ljubljanica river between Vrhnika and Ljubljana. These events could become a tradition, featuring workshops on fabrication of Early Watercraft. Sailing or paddling races could/should be transmitted to other continents, to locations with Early Watercraft Heritage Parks units. The department would also be responsible for organisation of conferences and other educational activities. An expert Early Watercraft conference, Early Watercraft reproducing and similar activities should be held every year.



Figure 65: One of the best known national parks which already realises the idea of an organised heritage park aimed at preserving and promoting the invention of Early Watercraft but also educates and promotes this aspect if heritage is Soomaa National Park – *Soomaa rahvuspark*. They strive to maintain the national traditions of making special extended logboat *habjaas* and produce a new replica each year during their annual festival (Photographer: Aivar Ruukel ©Soomaa National Park [On line] Available at: <<https://www.facebook.com/photo.php?fbid=10153270412661745&set=a.10150395108226745.402842.598636744&type=1>> [29. May 2015]).

## Selected basic bibliography

In decades of Early Watercraft studies it has been a lot of articles and books accumulated produced by researchers from different research field (e.g. archaeology, ethnology, anthropology, maritime studies, history, etc.) and from all around the world. We have also some fundamental publishing of the development and evolution of ship construction from the beginning to the contemporary types of modern watercraft. Nice work but with some shortcomings.

Just to get idea and have few selected books and articles on which base also the Initiative **Early Watercraft - A global perspective of invention and development:**

## References

- AGIUS, D. A. (2008). *Classic Ships of Islam: From Mesopotamia to the Indian Ocean*. Brill.
- ANTONIOLI, F. (2008). Archaeological and geomorphological data to deduce sea level changes during the late Holocene in the Northeastern Adriatic . In R. AURIEMMA & S. KARINJA (Eds.), *Terre di mare, l'archeologia dei paesaggi costieri e le variazioni climatiche, atti del convegno internazionale di studi trieste, novembre, 2007, trstpiran*. (pp. 221–234). Trst/Piran.

- ARNOLD, B. (1992). *Batellerie gallo-romaine sur le lac de Neuchâtel*. Neuchâtel; Saint-Blaise: Musée cantonal d'archéologie; Service cantonal de la conservation des monuments et des sites: Editions du Ruau.
- ARNOLD, B. (2002, April). Logboats from Europe and the CD-ROM, or a solution to the endless search for documents (2000 edition). *International Journal of Nautical Archaeology*, 31(1), 129–132.
- BAILLIE, M. G., & PILCHER, J. R. (1973). A simple crossdating program for tree-ring research. *Journal of Cultural Heritage*, 33, 7–14.
- BASS, F. G. (1966). *Archaeology Under Water*. New York: Praeger.
- BASS, G. F. (1974). *A History of Seafaring Based on Underwater Archaeology*. Omega Publications, Incorporated.
- BLACKMAN, D. (1996). New Evidence for Ancient Ship Dimensions. In E. H. TZALAS (Ed.), *Tropis iv, proceedings of 4th international symposium on ship construction in antiquity, athens, 28. - 31. august 1991* (pp. 1–13). Athens.
- BLACKMORE, J. (2006). *Connected by the Sea*.
- BOCKIUS, R. (2002). Abdichten, beschichten, kalfatern. Schiffsversiegelung und ihre Bedeutung als Indikator für Technologietransfers zwischen den antiken Schiffbautraditionen. In *Jahrbuch des römisch-germanischen Zentralmuseums mainz* (pp. 189–234). Römisch- germanischen Zentralmuseums Mainz.
- BOCKIUS, R. (2009). Between the Seas: Transfer and Exchange in Nautical Technology. In *Proceedings of the eleventh international symposium on boat and ship archaeology*. Römisch-Germanisches Zentralmuseum.
- BOCKIUS, R. (2011). Technological Transfer From the Mediterranean to the Northern Provinces. In G. BOETTO, P. POMEY, & A. TCHERNIA (Eds.), *Batellerie gallo-romaine pratiques régionales et influences ma-ritimes méditerranéennes, bibliothèque d'archéologie méditerranéenne et africaine* (pp. 47–59).
- BONNIN, P. (2003). Fabrication et utilisation de pirogues monoxyles. In G. de recherches archéologiques subaquatiques (Ed.), *Archeologie en essonne, actes de la journée archeologique de brunoy octobre* (pp. 29–41).
- BREUNIG, P. (1996). The 8000-year-old dugout canoe from Dufuna (NE Nigeria). In G. PWITI & R. SOPER (Eds.), *Aspects of african archaeology. papers from the th congress of the panafrican association for prehistory and related studies* (pp. 461–468). Harare.
- BRUNNING, R., WATSON, J., & ALLEN, S. (2010). *Waterlogged wood guidelines on the recording, sampling, conservation and curation of waterlogged wood*. Swindon: English

## Heritage.

- CASSON, L. (1984). *Ancient Trade and Society*. Mich.
- CASSON, L. (1991). *The Ancient Mariners: Seafarers and Sea Fighters of the Mediterranean in Ancient Times*. Princeton University Press.
- CASSON, L. (1994). *Ships and Seafaring in Ancient Times*. University of Texas Press.
- CASSON, L. (1995). *Ships and Seamanship in the Ancient World*. Johns Hopkins University Press.
- CRUMLIN-PEDERSEN, O., & THYE, B. M. (1995). The Ship as Symbol: In Prehistoric and Medieval Scandinavia . In *Papers from an international research seminar at the danish national museum, copenhagen, th-th may*. National Museum of Denmark, Department of Archaeology and Early History.
- DEAR, I., & KEMP, P. (2006). *The Oxford Companion to Ships and the Sea*. Oxford University Press.
- ECS, E. C. f. S. (1994). *Durability of wood and wood-based products — Natural durability of solid wood* .
- ERIČ, M. (2008). *Archaeology of Ljubljansko barje: Ships, Logboats, Ship toy and paddles; Evidence of vessels detected on Ljubljansko Barje* (Tech. Rep.).
- ERIČ, M. (2009). Datirani deblaki in ladja na Ljubljanskem barju in v Prekmurju v Sloveniji . In L. BEKIĆ (Ed.), *Jurišičev zbornik*. (pp. 151–162). Zadar.
- ERIČ, M., GASPARI, A., & KAVUR, B. (2012). Finds of logboats on the Ljubljansko barje after 1990 and current state of research / Arheološke najdbe čolnov deblakov na Ljubljanskem barju v letih 1990–2010. In *Potopljena preteklost* (pp. 397–404). Radovljica.
- FABRE, D. (2004). *Seafaring in Ancient Egypt*. Periplus.
- FORBES, R. J. (1955). *Studies in Ancient Technology* (Vol. III). Brill Archive.
- FRY, M. F. (2000). *Coiti*. Greystone Books Limited.
- GARDINER, R., & CHRISTENSEN, A. E. (1996). *The Earliest Ships* (1st ed.). Conway Maritime Press.
- GASPARI, A. (2012). Underwater archaeological investigation in Slovenia. Historical overview and perspectives. In A. GASPARI & M. ERIČ (Eds.), *Submerged past* (pp. 13–17). Radovljica: Didakta.
- GREENHILL, B., & MORRISON, J. S. (1995). *The Archaeology of Boats & Ships: An Introduction*. Naval Institute Press.
- GREGORY, N. (1997). *A Comparative Study of Irish and Scottish Logboats* (Unpublished doctoral dissertation).

- HEARN, C. J. (2008). *The Dynamics of Coastal Models*. Cambridge University Press.
- HOCKER, F. M., & WARD, C. A. (2004). *The Philosophy of Shipbuilding: Conceptual Approaches to the Study of Wooden Ships*. Texas A & M University Press.
- HORNELL, J. (1920). *The Origins and Ethnological Significance of Indian Boat Designs: Boat types now existing in India*. South Indian Federation of Fishermen Societies.
- HORNELL, J. (1946). *Water Transport, Origins and Early Evolution*. the University Press.
- HOURANI, G. F., & CARSWELL, J. (1995). *Arab Seafaring in the Indian Ocean in Ancient and Early Medieval Times*. Princeton University Press.
- HOWARD, P. (2003). *Heritage: Management, Interpretation, Identity*. Bloomsbury Publishing.
- JONES, D. (1995). *Boats*. University of Texas Press.
- KNIGHTON, D. (1998). *Fluvial forms and processes: a new perspective*. London; New York: Arnold; Oxford University Press.
- KOSE, M. (2012). A Ramsar Case Study on Tourism and Wetlands -Wetland Tourism: Estonia - Soomaa National Park. In *Proceedings of the th meeting of the conference of the contracting parties ramsar, bucharest, july -*. Bucharest.
- LENČEK, L. R. (1950). Poročilo o čupi. In *Izvestje srednih šol v britsko-ameriškem pasu svobodnega tržaskega ozemlja za šolsko leto 1949-1950* (pp. 3–7). Trst: La Editoriale Libreria S.p.A.
- LIU, L., & JIANG, L. (2005). The discovery of an 8000-year old dugout canoe at Kuahuqiao in the Lower Yangzi, China. *Antiquity*, 79(305).
- MacDOWELL, U. (1982). *Irish Logboat* (Unpublished master's thesis). University College Dublin.
- McGRAIL, S. (2004). *Boats of the World: From the Stone Age to Medieval Times*. Oxford University Press.
- McGRAIL, S. (2014). *Ancient Boats in North-West Europe: The Archaeology of Water Transport to AD 1500*. Taylor & Francis.
- McGRAIL, S., & KENTLEY, E. (1985). *Sewn plank boats: archaeological and ethnographic papers based on those presented to a conference at Greenwich in November, 1984*. B.A.R.
- McKERCHER, B., & Du CROS, H. (2012). *Cultural Tourism: The Partnership Between Tourism and Cultural Heritage Management*. Taylor & Francis.
- MELIK, A. (1946). *Ljubljansko mostiščarsko jezero in dediščina po njem* (Dela 1. razreda SAZU ed., Vol. 5). Ljubljana: Slovenske akademije znanosti in umetnosti.
- MILLSON, D. C. E. (2011). *Experimentation and Interpretation: The Use of Experi-*

- tal Archaeology in the Study of the Past. In *Theoretical archaeology group england conference*. Oxbow Books.
- OLESON, J. P. (2009). *The Oxford Handbook of Engineering and Technology in the Classical World*. Oxford University Press.
- OOSTING, R., & Van den AKKER, J. (Eds.). (2006, April). *Rivierscheepvaart*.
- OSSOWSKI, W. (1999). *Studia nad łodziami jednopiennymi z obszaru Polski*. Marpress.
- PETKOVŠEK, M., ZUPANC, M., DULAR, M., Kosjek, T., HEATH, E., Kompare, B., & ŠIROK, B. (2013, October). Rotation generator of hydrodynamic cavitation for water treatment. *Separation and Purification Technology*, 118(118), 415–423.
- ROUZO, P., & POSSONNIER, B. (2007). Fabrication expérimentale d'une pirogue monoxyde en chêne. *Archéopages*, 18-20(18), 58–63.
- SCHWEINGRUBER, H. F. (1990). *Microscopic wood anatomy / Mikroskopische holzanatomie*. Birmensdorf, Switzerland: Wiley Periodicals, Inc.
- SMITH, L., & AKAGAWA, N. (2008). *Intangible Heritage*. Taylor & Francis.
- SONG, M. (2009). *Virtual Reality for Cultural Heritage Applications*. VDM Publishing.
- STEFFY, R. J. (2011). *Wooden Ship Building and the Interpretation of Shipwrecks*. Texas A & M University Press.
- THROCKMORTON, P. (1962). Oldest Known Shipwreck Yields Bronze age Cargo. *National Geographic Magazine*, 121, 697–711.
- THROCKMORTON, P. (1987). *History from the Sea: Shipwrecks and Archaeology*. Reader's Digest.
- TZALAS, E. H. (1996). *On Ship Construction in Antiquity*. Tropis IV, Proceedings of 4th International Symposium On Ship Construction in Antiquity, Athens, 28. - 31. august 1991. Athens.
- Van ZEIST, W. (1957). De Mesolitische Boot van Pesse. *Nieuwe Drentse Volksalmanak*, 75, 4–11.
- WACHSMANN, S., & BASS, G. F. (2008). *Seagoing Ships and Seamanship in the Bronze Age Levant*. Texas A&M University Press.
- WARD, C. A. (2000). *Sacred and Secular: Ancient Egyptian Ships and Boats*. Archaeological Institute of America, Boston, MA.
- WESTERDAHL, C. (1985). Sewn boats of the North: A preliminary catalogue with introductory comments. Part 1. *International Journal of Nautical Archaeology*, 14(1), 33–62.