

# A Brief History of Ships' Hulls and Anchors as Revealed Along the Turkish Coast by the Institute of Nautical Archaeology



*George F. Bass, Deborah N. Carlson, and Mark E. Polzer*

*Illustrated by Mark E. Polzer*

When the founders of the Institute of Nautical Archaeology (INA), George Bass and Michael Katzev, began their investigation of ancient shipwrecks off the coasts of Turkey and Cyprus in the 1960s, first for the University of Pennsylvania Museum, it was known that Roman ships, at least, were built in the shell-first manner, their planks held together, edge to edge, by mortise-and-tenon joints, the tenons driven into mortises cut in the plank edges and locked in place by wooden pegs (Fig. 1). Evidence had come from such oddities as the fancifully named “Caesar’s galley,” found during the construction of a building at Marseille in 1864;<sup>1</sup> the County Hall ship, also uncovered during construction on land, this time in 1910 near the River Thames in London;<sup>2</sup> the Antikythera wreck,

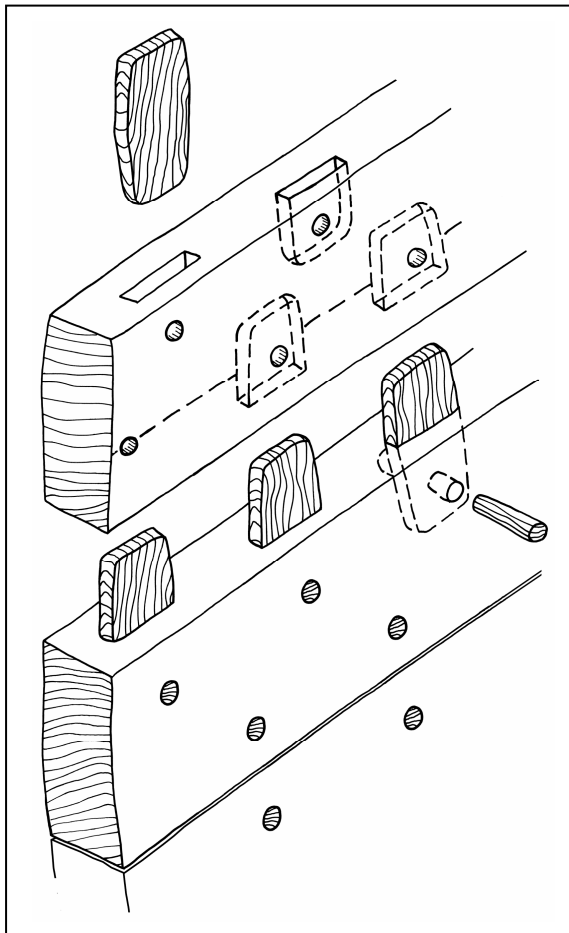

Fig. 1. Pegged mortise-and-tenon planking edge joinery.

“excavated” by Greek sponge divers in the opening years of the twentieth century;<sup>3</sup> and the two immense Roman barges revealed when Mussolini lowered the level of Italy’s Lake Nemi by means of enormous pumps to reveal their hulls.<sup>4</sup> Nothing, however, was known of Archaic, Classical, or Byzantine ship construction. And a history of the evolution of the anchor contained gaps.

The pioneers named above, their collaborators, and those who followed in INA have now, through carefully controlled excavations along the Turkish coast, and in northern Cyprus, outlined the history of hull construction in the eastern Mediterranean from the Bronze Age until Late Byzantine times. At the same time, they have provided a clear picture of the development of anchor types through the same periods.

### Uluburun Late 14th Century BCE

The oldest known seagoing hull, excavated between 1984 and 1994,<sup>5</sup> by Cemal Pulak off Uluburun, near Kaş, has been dated by dendrochronology to about 1300 BCE. It was constructed of cedar planks 6 cm thick, with oak tenons held tight inside their mortises by oak pegs driven through pre-drilled holes (Fig. 2). The tenons, sometimes 30 centimeters long, reach almost to the farthest edges of the planks. The ship’s bottom plank was a rudimentary keel that strengthened the hull, but, extending only two centimeters beyond the hull’s bottom, did not allow the ship to sail close to the wind. There is no evidence of frames (commonly called ribs), but it should be noted that only a small portion of the hull survived. A wicker fence, a kind of spray shield

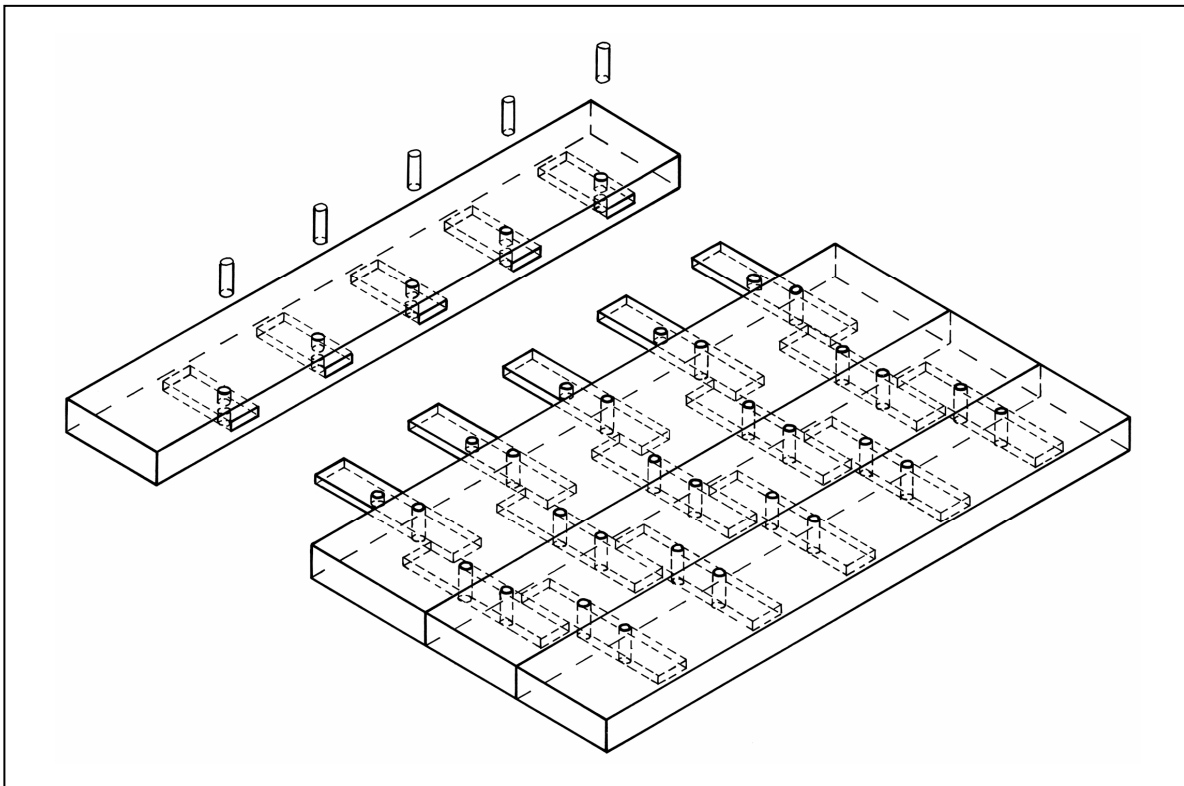

Fig. 2. *The mortise-and-tenon joints of the Uluburun ship (after W. van Duivenvoorde).*

---

like that described by Homer and depicted in Egyptian tomb paintings of contemporary Syrian ships, was found well preserved. Some of the 20 tons of cargo, ballast, and anchors rested on a cushion of brushwood dunnage, explaining the brushwood mentioned by Homer in his description of Odysseus completing the watercraft on which he left Calypso's island.<sup>6</sup>

The Uluburun ship carried 24 stone anchors of Near Eastern type, slabs weighing, except for the two smallest, between 120 and 210 kg, each with a hawser hole near its top (Fig. 3A).<sup>7</sup>

#### **Taşlıkburun (Cape Gelidonya) Late 13th Century BCE**

During the pioneering 1960 excavation of the slightly later wreck at Cape Gelidonya (Taşlıkburun), of around 1200 BCE, Bass knew so little of ship construction that he did not recognize a tenon much like those used on the Uluburun ship, although he illustrated it in the site's publication.<sup>8</sup> Shelley Wachsmann first suggested it was a tenon,<sup>9</sup> and later Pulak, studying one of the unpublished excavation photographs, was led to evaluate all of the wood, from which he concluded that the Cape Gelidonya ship was built much like the Uluburun ship.<sup>10</sup> Bass did, however, first demonstrate that the brushwood mentioned by Homer (*Odyssey* 5. 256-7) was dunnage,<sup>11</sup> as corroborated at Uluburun. As at Uluburun, there was no evidence of frames.

It is not known how many anchors this ship might have carried, but one, similar to but larger

(219 kg) than those at Uluburun, was located about 70 m from the wreck in 1994 by INA staff under the direction of Pulak exploring the surroundings of the excavated wreck site with underwater motor scooters.<sup>12</sup>

#### **Pabuç Burnu Late 6th Century BCE**

One might then be inclined to conclude that the evolution of ship construction from the Bronze Age into Roman times moved in a straight, unbroken line, but it is not that simple. The first excavation of an Archaic Greek ship in the Aegean, off Pabuç Burnu, near Bodrum, was undertaken in 2002 and 2003, under the direction of Bass, Elizabeth Greene, and Mark Polzer. The pine (*Pinus nigra*) planks of this sixth-century BCE wreck, like planks of contemporaneous hulls studied in France and Italy,<sup>13</sup> were not mortise-and-tenon joined, but were laced together with ligatures made of fibrous plants run through pre-fashioned holes (Fig. 4). Prior to being laced, two adjoining strakes were aligned edge-to-edge and held in place by dowels seated in holes drilled into the planks' edges, or, in certain areas of the hull, by unpegged mortise-and-tenon joints. After the planks were laced tightly together, the shipwright hammered an alder peg into each hole to hold fast the ligature and to waterproof the hole. There is indirect evidence of frames, the earliest known in the Aegean, held in place by ligatures and, in some cases, by treenails (wooden dowels).<sup>14</sup> The Pabuç Burnu hull provides evidence of the early adaptation of the mortise-and-tenon technique into the Greek tradition of laced construction.

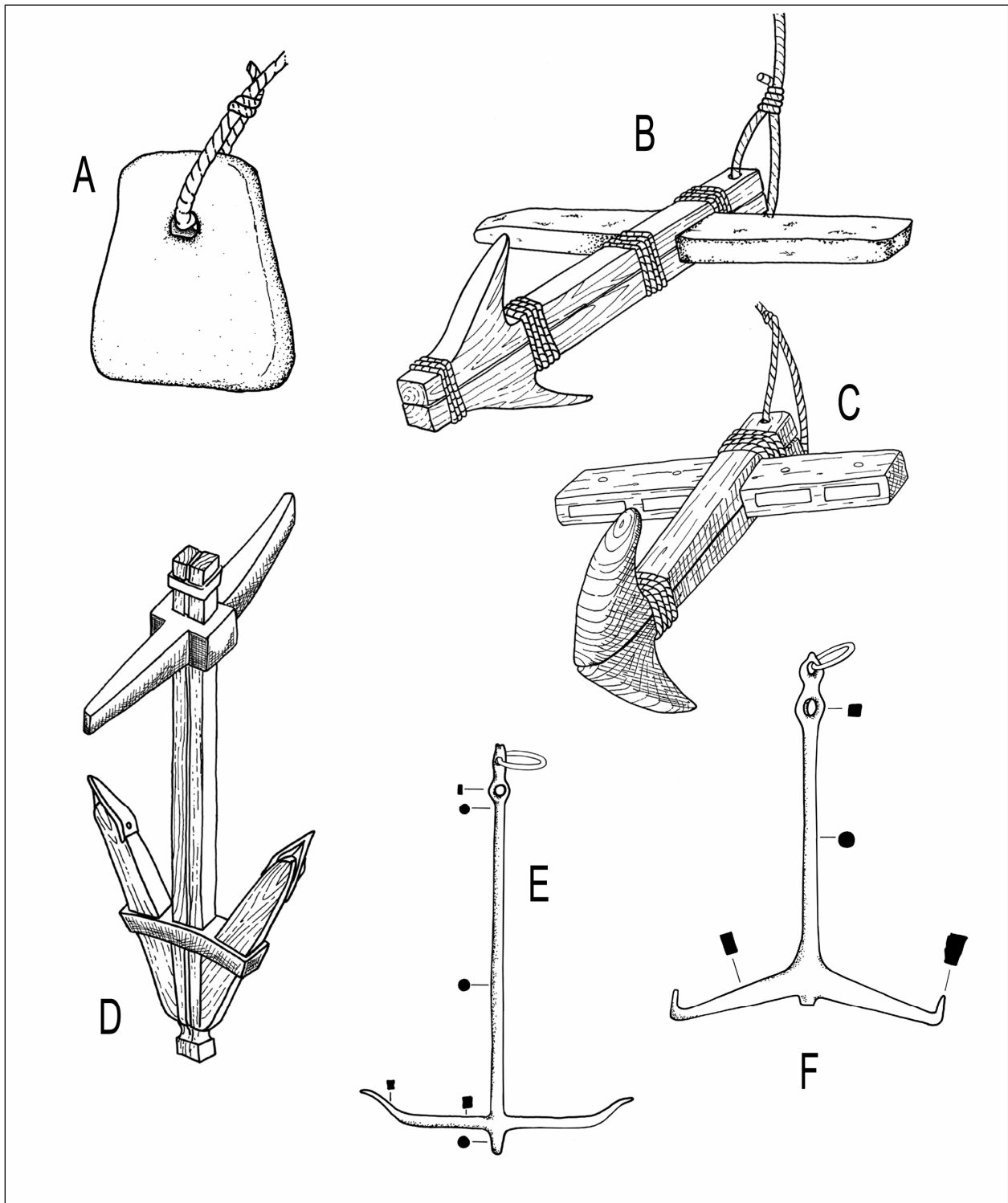

Fig. 3. Anchors: (A) Uluburun stone anchor; (B) stone anchor stocked from Pabuç Burnu (after G. Kapitän); (C) anchor stock with four lead cores from Tektaş Burnu (after R. La Pointe); (D) Roman anchor with lead stock (after F. Benoit); (E) cruciform iron anchor from the Yassada 7<sup>th</sup>-century wreck (after F. van Doorninck); (F) Y-shaped iron anchor from the Serçe Limanı wreck (after S. Matthews).

By this time sailors had invented a hooked anchor with heavy stone stock to force the hook into the seabed. The Pabuç Burnu wreck yielded one large stock of white limestone (1.65 m long, weighing 115 kg; Fig. 3B), and a smaller, dark gray, basaltic stone (45 cm long, weighing only 7.32 kg) that could possibly have come from the anchor of a dinghy towed behind the ship.<sup>15</sup>

### Tektaş Burnu 5th Century BCE

Does evidence from Pabuç Burnu imply that Bronze Age mortise-and-tenon joints were replaced by lacing as the primary means of fastening planks together in the Archaic period, and that lacing was, in turn, replaced by mortise-and-tenon joints sometime in the Classical period? Not necessarily. The two Bronze Age ships were surely Near Eastern in origin, and that at Pabuç Burnu more probably Greek. Perhaps there were two early

traditions, a Near Eastern tradition of pegged mortise-and-tenon joined hulls, and a Greek tradition of laced hulls, with the Greeks adapting the mortises and tenons of their Semitic neighbors at some time in the sixth or fifth century BCE. The hull of the only fifth-century BCE shipwreck so far excavated to completion, by Bass and Deborah Carlson between 1999 and 2001 at Tektaş Burnu, near Çeşme, did not survive because of the rocky terrain upon which it settled, but clenched copper nails, oak tenons, and fragments of pine frames suggest that it was constructed much like the Kyrenia ship, built about a century later.<sup>16</sup>

Numerous ancient Greek vase paintings depict ships with eyes, or *ophthalmoi*, on their bows. Marble *ophthalmoi* have been found in Greek warship sheds, but it was not known if the eyes of merchant ships were similar, or simply

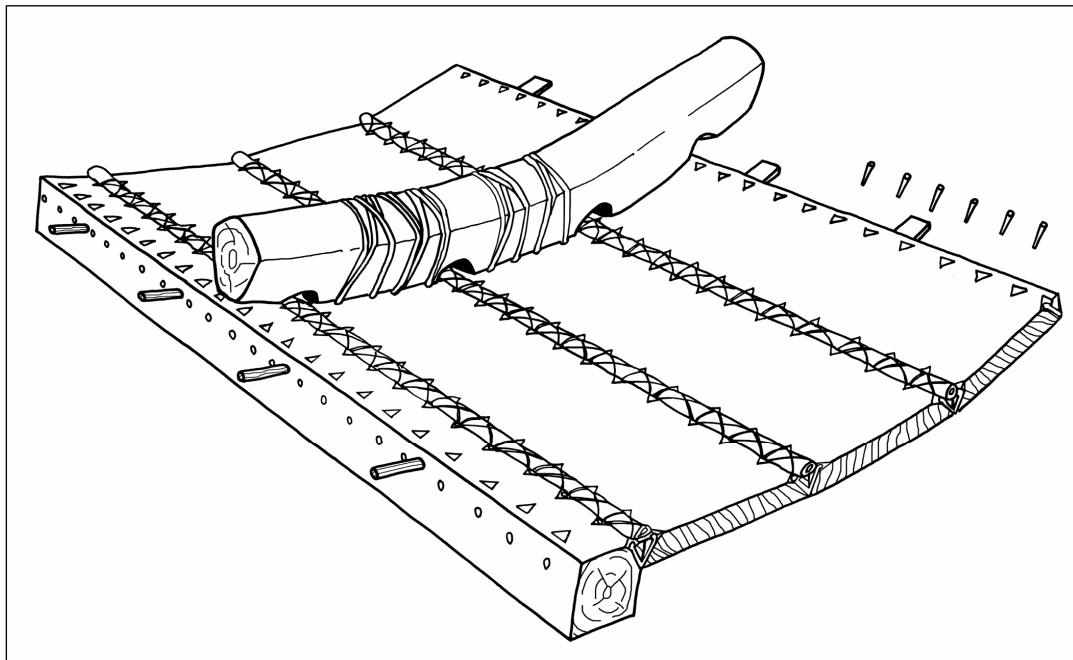

Fig. 4. Details of Archaic Greek laced hull construction (after Pomey, Centre Camille Jullian, CNRS France).

---

painted on. The discovery of two white marble disks, each about 14 cm in diameter, decorated with a painted, incised band on the outer convex face, and pierced through the center by a lead spike, showed that at least the Tektaş Burnu ship's eyes were actual appliquéés attached to the bow.<sup>17</sup>

Remnants of five wooden anchors, in the form of 14 lead bars, or stock cores, also came to light at Tektaş Burnu. Made by pouring molten lead into hollowed elm anchor stocks (Fig. 3C), they represent a transitional phase in anchor construction, away from earlier stocks fashioned entirely of stone (as at Pabuç Burnu) and toward later stocks made entirely of lead (Fig. 3D).<sup>18</sup> The largest anchor, more than 1 m long and containing four separate lead cores, was located 54 m deep at the base of a shelf on which the wreck settled, suggesting that it was cast out in a futile attempt to keep the ship from striking the rocky coastline.

#### **Kyrenia (Girne), Cyprus 4th Century BCE**

The astonishingly preserved ship excavated by Michael and Susan Womer Katzev off Kyrenia (Girne), Cyprus, in the late 1960s, provides the best firsthand glimpse we have of an ancient Greek ship. Although coins and other evidence suggest that it sank in the early third century BCE, radiocarbon dating of its hull suggests that it was built decades earlier and had seen many years at sea. Its planks of Aleppo pine (*Pinus halepensis*) were fastened edge to edge by pegged mortise-and-tenon joints, the tenons and pegs made of Turkey oak (*Quercus cerrus* L.). The mortises were not nearly as large as

those used in the Uluburun and Cape Gelidonya hulls, but they were staggered from one side of each plank to the other (Fig. 5A). When the hull was completed, frames were attached to the hull's interior by copper nails driven from the hull's exterior through wooden dowels (treenails) that had been inserted through drill holes that pierced both the planking and the frames; the nails were then clenched over inside to prevent their withdrawal.<sup>19</sup>

Wooden anchor stocks at Kyrenia, like those at Tektaş Burnu, contained lead cores.<sup>20</sup>

#### **Kızılburun 1st Century BCE**

Roman wrecks off the French and Italian coasts have been so well excavated and published, especially that at Madrague de Giens, France,<sup>21</sup> that INA has not undertaken the excavation of one, although as this is written Carlson is planning the excavation at Kızılburun, near Tektaş Burnu, of a Roman *navis lapidaria*, or stone carrier, dating from the second or first century BCE. Lying between 45 and 48 m deep, the wreck is distinguished by eight enormous column drums, stacked neatly in four pairs, on top of which lie what appear to be a Doric capital and other flat stone slabs. When reconstructed, these eight unfluted drums would form a column over 10 m tall. We are optimistic that the size, arrangement, and weight of the column drums will preserve intact a significant portion of the ship's hull and offer a glimpse into the construction employed for such specialized transport vessels.

### Yassiada 4th/5th Century

A Late Roman/Early Byzantine wreck of the late fourth or early fifth century was mostly excavated in 1967, 1969, and 1974 off Yassiada, near Bodrum, by Bass and Frederick van Doorninck, Jr.<sup>22</sup> By this time, the beginning of the centuries-long evolution from ancient shell-first construction, with planks held together either by mortise-and-tenon joints or by lacing, to modern frame-first construction seems to have been under way. In this case, the oak tenons were smaller, more loosely fitting, and spaced farther apart than those in the earlier Greek and Roman ships, with more emphasis for strength placed on frames fastened to the cypress hull planking with oak treenails instead of copper nails (Fig. 5B).<sup>23</sup>

The ship's anchors were not found. Perhaps some had been cast in a vain attempt to save the ship, and others may still lie farther downslope than the excavation reached.

### Yassiada Early 7th Century

Around AD 626, as shown by dozens of copper and gold coins left on board, a ship sailed by Giorgios Priest/Sea-Captain, sank only a few meters from the Late Roman shipwreck off Yassiada. In this transitional period between the ancient and modern eras, we see a perfect example of transitional ship design. Excavations by Bass and van Doorninck in 1961 through 1964 showed that this early seventh-century ship was built in the ancient manner, with mortise-and-tenon joints, up to the waterline, although the joints were small, no

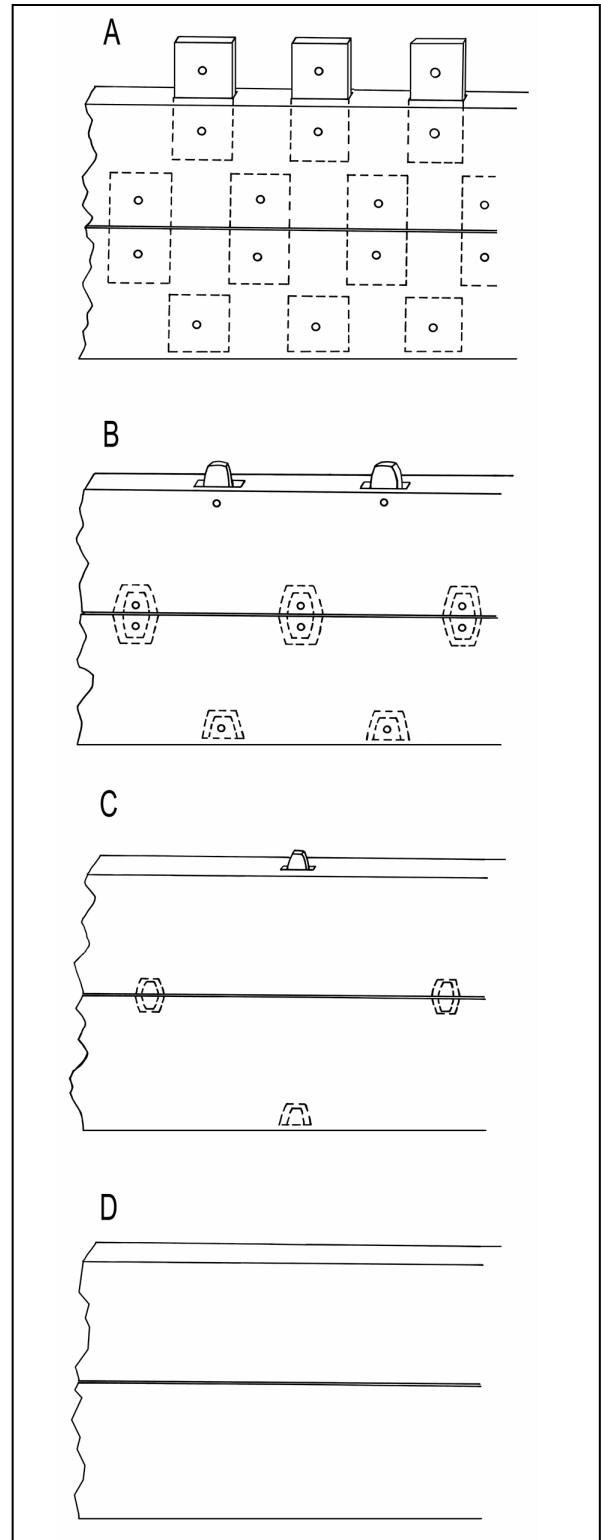

Fig. 5. The evolution of mortise-and-tenon joinery in ship construction as revealed by shipwrecks at: (A) Kyrenia; (B) Yassiada 4th century; (C) Yassiada 7th century; and (D) Serçe Limanı (after F. van Doorninck).

---

longer pegged, and spaced even farther apart than in the ship last described (Fig. 5C). Then the shipwright positioned the ship's elm frames inside the hull, keeping them in place with iron nails hammered into the hull from outside, and finally, with more iron nails, fastened the remainder of the hull's pine planks to these frames.<sup>24</sup>

We know a great deal about the tile-roofed cabin near the ship's stern, and the tiled firebox with which the ship's cook prepared meals on the cabin's port side. Detailed site plans show that the ship's carpenter stored his iron tools in a chest forward in the cabin, whereas the boatswain kept his tools, for foraging for water and firewood ashore, in a locker astern of the cabin.<sup>25</sup>

When the ship hit the Yassıada reef and sank, it was carrying 11 cruciform, or T-shaped, iron anchors with wooden and iron stocks of a type possibly introduced in the fourth century (Fig. 3E). Seven lay on deck, stacked just forward of the ship's mast, and a pair of bowers on either bulwark were ready for use. Van Doorninck calculated from the mass of iron in the anchors of increasing size that their weights were based on an arithmetic progression of multiples of the pound then in use, suggesting that thirteenth-century Genoese laws governing the weights of anchors on ships of various sizes may have had their origins in the seventh century or earlier.<sup>26</sup>

### **Bozburun 9th Century**

By the ninth century AD, as shown by another Byzantine shipwreck, this one excavated by Frederick Hocker and Bass near Selimiye on Bozburun, the move toward modern ship design was almost complete.<sup>27</sup> Indeed, it was first believed that this hull was built entirely in the frame-first manner, its oak planks bent around and nailed to a pre-erected framework of pine. Matthew Harpster later noted nearly invisible traces of dowels that held some planks to one another. The evolution to modern ship design was not yet complete.

### **Serçe Limanı Early 11th Century**

Although better known for its astonishing cargo of glass, the ship that sank around AD 1025 inside Serçe Limanı on the southwest Turkish coast was excavated primarily to determine if the move toward modern design and construction had yet reached finality.<sup>28</sup> The answer was affirmative. The hull of pine planking with elm keel, reassembled in the Bodrum Museum of Underwater Archaeology, represents the earliest hull whose shape was determined with certainty by the skeleton of frames onto which the planks were attached with iron nails (Fig. 5D). In a sense, this is the earliest known "modern ship."

The ship carried at least nine Y-shaped iron anchors, a shape van Doorninck suggests was based on a need to increase anchor weight, to suit larger ships, without lengthening shanks (Fig. 3F). In other words, the new shape was based on the economic desire to keep manufacturing costs as



---

low as possible.<sup>29</sup> Eight of the anchors were still stored on the ship, but the ninth was found some distance forward of the wreck site, its shank broken, perhaps from a sudden and severe gust of wind, a clue to the cause of the wreck. The anchors used wooden stocks and had standardized weights and dimensions.

### **Çamaltı Burnu 13th Century**

Although not an INA excavation, we were delighted to have collaborated modestly with our colleague Nergis Günsenin during her excavation between 1998 and 2004 of a thirteenth-century Byzantine shipwreck off Marmara Island's Çamaltı Burnu in the Sea of Marmara.<sup>30</sup> The hull remnants were scanty, but they showed that this ship, like that at Serçe Limanı, was built in the modern, frame-first manner; at least one plank was fashioned of pine and at least one frame was elm.

More than 30 iron anchors, both Y-shaped and T-shaped, but all Byzantine, were probably part of the ship's cargo, as many were too small for the ship and were no longer in usable condition.

### **Summary**

Now that we have traced the development of modern wooden hulls of the type that allowed explorers to encircle the globe, we should ask the causes of the evolution. If there was a Greek tradition of laced hulls, which remains speculative until the discovery and excavation of a Mycenaean hull, did improvements in warship ramming cause Greeks to adopt the stronger mortise-and-tenon joined hulls of their Semitic neighbors? But why the later move away from mortise-and-tenon joinery? The cutting of thousands of mortises and tenons was extremely labor-intensive. Was a decrease in slavery in Byzantine times a reason for the slow change? Shell-first hulls required far more timber than hulls crafted by bending planks around pre-erected frameworks, for much of their wood was simply carved away to shape their planks. Was deforestation another contributing factor? Whatever the answers, decades of pioneering archaeological work in Turkish waters have made it possible to stitch together a framework of the major phases in ancient Mediterranean ship construction and anchor design, providing the world new evidence with which to interpret larger social, economic, and environmental issues.



---

## Bibliography

- Bass, G.F. 1967. *Cape Gelidonya: A Bronze Age Shipwreck*. TAPS 57, Part 8.
- Bass, G.F., ed. 1972. *A History of Seafaring Based on Underwater Archaeology*. London: Thames & Hudson; New York: Walker & Co. (also in Dutch, French, Swedish, Italian and German editions).
- Bass, G.F. 1999. "The Hull and Anchor of the Cape Gelidonya Ship." P.P. Betancourt, V. Karageorghis, R. Laffineur, and W.-D. Niemeier (eds.), *Meletemata*, 21-4. *Aegaeum* 20. Liège and Austin.
- Bass, G.F., and F.H. van Doorninck, Jr. 1971. "A Fourth-Century Shipwreck at Yassi Ada." *AJA* 75:27-37.
- Bass, G. F., and F.H. van Doorninck, Jr. 1982. *Yassi Ada*. Vol. 1, *A Seventh-Century Byzantine Shipwreck*. College Station: Texas A&M University Press.
- Bass, G.F., S. Matthews, J.R. Steffy and F.H. van Doorninck, Jr. 2004. *Serçe Limanı: An Eleventh-Century Shipwreck*. Vol. I, *The Ship and its Anchorage, Crew and Passengers*. College Station: Texas A&M University Press.
- Carlson, D.N. 2003. "The Classical Greek Shipwreck at Tektaş Burnu, Turkey." *AJA* 107:581-600.
- Greene, E.S., and M.E. Polzer. 2004. "Evidence for a Sixth-Century BCE Lifeboat and its Anchor?" *INA Quarterly* 31.3:12-8.
- Günsenin, N. 2001. "L'épave de Çamaltı Burnu I (île de Marmara, Proconnèse): resultants des années 1998-2000." *Anatolia Antiqua* 9:117-33.
- Günsenin, N. 2003. "L'épave de Çamaltı Burnu I (île de Marmara, Proconnèse): résultats des années 2001-2002." *Anatolia Antiqua* 11:361-76.
- Günsenin, N. Forthcoming. "The Çamaltı Burnu I Wreck: A 13th-Century Wine Carrier." G.F. Bass (ed.), *Beneath the Seven Seas: Adventures with the Institute of Nautical Archaeology*. London and New York: Thames and Hudson.
- Hocker, F. Forthcoming. "The Ninth-Century Bozburun Ship." G.F. Bass (ed.), *Beneath the Seven Seas: Adventures with the Institute of Nautical Archaeology*. London and New York: Thames and Hudson.
- Kahanov, Y., and P. Pomey. 2004. "The Greek [Se]wn Shipbuilding Tradition and the *Ma'agan Mikhael* Ship: A Comparison with Mediterranean Parallels from the Sixth to the Fourth Centuries BC." *The Mariner's Mirror* 90:6-28.
- Kahanov, Y. & E. Linder. 2004. *The Ma'agan Mikhael Ship: The Recovery of a 2400-Year-Old Merchantman, Final Report*, Vol. 2, John Tresman, ed. Jerusalem: Israel Exploration Society and University of Haifa.
- Kapitän, G. 1973. "Greco-Roman Anchors and the Evidence for the One-Armed Wooden Anchor in Antiquity." D. Blackman (ed.), *Marine Archaeology*, 383-94. Hamden, Connecticut: Archon Books.

- 
- Marsden, P. 1972. "Ships of the Roman Period and after in Britain." G.F. Bass (ed.), *A History of Seafaring Based on Underwater Archaeology*, 113-32. London: Thames & Hudson, and New York: Walker & Co.
- Nowak, T.J. 2001. "A Preliminary Report on *Ophthalmoi* from the Tektaş Burnu Shipwreck." *IJNA* 30:86-94.
- Polzer, M.E. 2004. "An Archaic Laced Hull in the Aegean: The 2003 Excavation and Study of the Pabuç Burnu Ship Remains." *INA Quarterly* 31.3:3-11.
- Pulak, C. 1999. "The Late Bronze Age Shipwreck at Uluburun: Aspects of Hull Construction." W. Phelps, Y. Lolos, and Y. Vichos (eds.), *The Point Iria Wreck*, 209-38. Athens: Hellenic Institute of Marine Archaeology.
- Pulak, C., and E. Rogers. 1994. "The 1993-1994 Turkish Shipwreck Surveys." *INA Quarterly* 21.4:17-21.
- Steffy, J.R. 1985. "The Kyrenia Ship: an Interim report on Its Hull Construction." *AJA* 89:71-101.
- Steffy, J.R. 1994. *Wooden Ship Building and the Interpretation of Shipwrecks*. College Station: Texas A&M University Press.
- Tchernia, A, P. Pomey, et al. 1978. *L'épave romaine de la Madrague de Giens (Var) (Campagnes 1972-1975)*. Gallia suppl. 34. Paris.
- Throckmorton, P. 1972. "Romans on the Sea." G.F. Bass (ed.), *A History of Seafaring Based on Underwater Archaeology*, 65-86. London: Thames & Hudson, and New York: Walker & Co.
- Trethewey, K. 2001. "Lead Anchor-Stock Cores from Tektaş Burnu, Turkey." *IJNA* 30:109-14.
- Van Doorninck, F.H., Jr. 1972. "Byzantium, Mistress of the Sea: 330-641." G.F. Bass (ed.), *A History of Seafaring Based on Underwater Archaeology*, 133-58. London: Thames & Hudson, and New York: Walker & Co.
- Van Doorninck, F.H., Jr. 1976. "The Fourth-Century Wreck at Yassi Ada: An Interim Report on the Hull." *IJNA* 5:115-31.
- Wachsmann, S. 1998. *Seagoing Ships and Seamanship in the Bronze Age Levant*. College Station: Texas A&M University Press, and London: Chatham.

## Notes

---

- <sup>1</sup> Throckmorton 1972, 69, 81.
- <sup>2</sup> Marsden 1972, 116-7, 128.
- <sup>3</sup> Throckmorton 1972, 69-70.
- <sup>4</sup> Throckmorton 1972, 69, 71, 82.
- <sup>5</sup> Bass directed the 1984 campaign, and turned the excavation over to Pulak the following summer.
- <sup>6</sup> Pulak 1999.
- <sup>7</sup> Pulak 1999, 210-1
- <sup>8</sup> Bass 1967, 50, fig. 51 Wd 2.
- <sup>9</sup> Wachsmann 1998, 217-8.
- <sup>10</sup> Bass 1999.
- <sup>11</sup> Bass 1967, 49.
- <sup>12</sup> Pulak and Rogers 1994, 20-1; Bass 1999, 23 and pl. Vb.
- <sup>13</sup> Kahanov and Pomey 2004; Kahanov and Linder 2004, 49-76..
- <sup>14</sup> Polzer 2004, 7-9.
- <sup>15</sup> Greene and Polzer 2004.
- <sup>16</sup> Carlson 2003, 594.
- <sup>17</sup> Nowak 2001; Carlson 2003, 594-6.
- <sup>18</sup> Trethewey 2001.
- <sup>19</sup> Steffy 1985; 1994, 43-54.
- <sup>20</sup> Kapitän 1973, 390.
- <sup>21</sup> Tchernia, Pomey, et al. 1978; see also Steffy 1994, 62-5.
- <sup>22</sup> Bass and van Doorninck 1971, 29-34.
- <sup>23</sup> van Doorninck 1976; 1972, 137-9.
- <sup>24</sup> Bass and van Doorninck 1982, 32-86.
- <sup>25</sup> Bass and van Doorninck 1982, 87-120.
- <sup>26</sup> Bass and van Doorninck 1982, 134.
- <sup>27</sup> Hocker, forthcoming.
- <sup>28</sup> Bass, Matthews, Steffy, and van Doorninck 2004, 73-169.
- <sup>29</sup> Bass, Matthews, Steffy, and van Doorninck 2004, 234-5.
- <sup>30</sup> Günsenin 2001; 2003; forthcoming.