

New Test for Determination of Masonry Tensile Bond Strength

Fouad M. Khalaf¹

Abstract: The bond strength between masonry units and mortar has been of considerable interest to researchers for some time. The flexural bond strength of masonry in particular is needed for the design of masonry walls subjected to horizontal forces applied normal to the face of the wall, such as wind forces. Researchers and standards have suggested different kinds of specimens and test procedures to determine the flexural bond strength. These include the test on wallettes (small walls), the bond wrench test, the Brench test, the direct tensile test, and the crossed couplet test. Each of these tests has its own drawbacks and problems. This paper presents a test method to determine the flexural bond strength, f_{fb} , by bending. The test could be used for laboratory research to investigate the many factors affecting bond strength and also for deriving design values for masonry standards. The specimen is constructed from two brick units in a Z-shaped configuration, and three-point loading induces a flexural bond failure parallel to the bed joint. Three different types of clay brick, one calcium silicate brick, and three different types of mortar were used in the experimental program. The results derived show that the proposed new specimen and test procedure are capable of determining the flexural bond strength easily and accurately.

DOI: 10.1061/(ASCE)0899-1561(2005)17:6(725)

CE Database subject headings: Bonding strength; Tensile strength; Tensions; Bricks; Mortars; Joints; Masonry.

Introduction

Many factors are known to influence the bond strength between the mortar joints and masonry units. These include the unit rate of suction, the surface roughness of the masonry units, the particle size distribution of sand, and the moisture content of mortar. Meanwhile, in practice, the workmanship of the bricklayer is often crucial (Hendry and Khalaf 2001; De Vekey et al. 1990; De Groot 1987; Held and Anderson 1983; Sinha 1967; Kamf 1963). The bond between brick and mortar is derived from penetration of the mortar and hydration products, such as calcium silicate hydrates, into the brick surface voids and pores (Lawrence and Cao 1987; Grandet 1975). The relative amount of lime in the mix is thought to be important in determining bond strength.

BS 5628 (British 1992) describes the testing of small brick/block wall specimens (wallettes) under four-point loading as a standard test for determination of the flexural bond strength of masonry bed joints, f_{fb} . The wallettes test arrangement is shown in Fig. 1 for planes of failure parallel and normal to the bed joint. The test specimens in Fig. 1 do not give the direct tensile bond strength, but many engineers regard it as of practical importance. The test provides an index of wall strength derived from its flexural performance. The difficulty with the BS 5628 test is the large specimen needed for the test and the test setup, which makes it cumbersome to perform. Based on the results of the wallettes test,

BS 2628 provides a table to derive the design values for the characteristic flexural bond strength, f_{kx} , for masonry walls subjected to wind forces (Table 1).

A bond wrench test developed in Australia has been in use for several years for laboratory research on bond strength, as a quality control tool for newly built masonry, and for in situ measurement of bond on existing structures. The test is specified in the Australian Code of Practice AS 3700 (Australian 1998). In the United States, the use of bond wrenches in the laboratory is now covered by ASTM Standards C 1072 (ASTM 2000) and C 1357 (ASTM 2002).

Based on the Australian bond wrench test, the U.K. Building Research Establishment (BRE) in Digest 360 (BRE 1991) covered the technical background of results for a bond wrench test called "Brench" (Fig. 2). BRE claimed that the Brench test could be used for investigating suspect masonry, for quality control of a new work, and for laboratory investigation of bond strength.

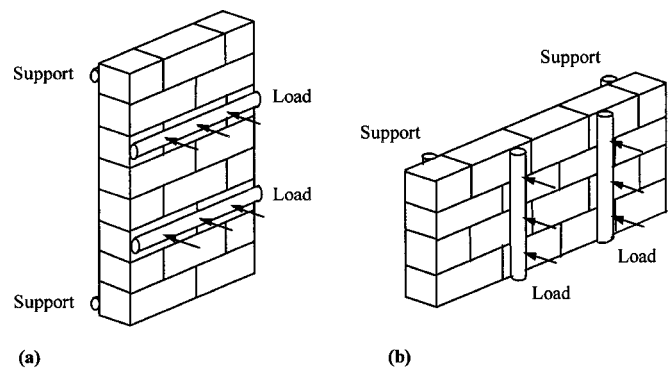

Fig. 1. Testing arrangement of wallettes (small walls), BS 5628 (British 1992): (a) plane of failure parallel to bed joint; (b) plane of failure normal to bed joint

¹Senior Lecturer, School of the Built Environment, Napier Univ., Edinburgh, EH10 5DT, Scotland, UK. E-mail: f.khalaf@napier.ac.uk

Note. Associate Editor: John S. Popovics. Discussion open until May 1, 2006. Separate discussions must be submitted for individual papers. To extend the closing date by one month, a written request must be filed with the ASCE Managing Editor. The manuscript for this paper was submitted for review and possible publication on March 17, 2003; approved on July 20, 2004. This paper is part of the *Journal of Materials in Civil Engineering*, Vol. 17, No. 6, December 1, 2005. ©ASCE, ISSN 0899-1561/2005/6-725-732/\$25.00.

Table 1. Characteristic Flexural Strength of Masonry, f_{kx} , in MPa from BS 5628 (British 1992)

Mortar designation	Plane of failure ^c parallel to bed joints			Plane of failure ^c perpendicular to bed joints		
	(i)	(ii) and (iii)	(iv)	(i)	(ii) and (iii)	(iv)
Clay bricks having a water absorption						
Less than 7%	0.7	0.5	0.4	2.0	1.5	1.2
Between 7 and 12%	0.5	0.4	0.35	1.5	1.1	1.0
Over 12%	0.4	0.3	0.25	1.1	0.9	0.8
Calcium silicate bricks	0.3		0.2	0.9		0.6
Concrete bricks	0.3		0.2	0.9		0.6
Concrete blocks (solid or hollow) of compressive strength in N/mm ²						
2.8	} Used in walls of thickness ^a up to 100 mm	} 0.25	} 0.2	0.40		0.4
3.5				0.45		0.4
7.0				0.60		0.5
2.8	} Used in walls of thickness ^a 250 mm	} 0.15	} 0.1	0.25		0.2
3.5				0.25		0.2
7.0				0.35		0.3
10.5	} Used in walls of any thickness ^a	} 0.25	} 0.2	0.75		0.6
14.0 and over				0.90 ^b		0.7

^aThickness should be taken to be the thickness of the wall, for a single-leaf wall, or the thickness of the leaf, for a cavity wall.

^bWhen used with flexural strength in parallel direction, assume the orthogonal ratio $\mu=0.3$.

^cSee Fig. 1.

The Brenc consists of a lever about 800 mm long that weighs about 9 kg. At one end are jaws that can be adjusted to fit the common thicknesses of masonry. The jaws are tightened on the masonry by a screw mechanism. At the other end is a crossbar handle, mounted on a load cell. Load is applied manually by putting body weight onto the crossbar handle, which ensures that all operators press down on the Brenc at the same distance from the masonry. Partway along the body is a combined battery container and liquid crystal display (LCD) type display showing the applied load. The display indicates the maximum reading until reset. BRE also claims that the Brenc is safe to use because, as the brick/block comes free, the handle moves away from the operator and towards the wall.

Riddington and Jukes (1994) used direct pull tests, bending tests on stacks, and wrench tests to determine and compare results of bond strength. Various brick and mortar combinations were

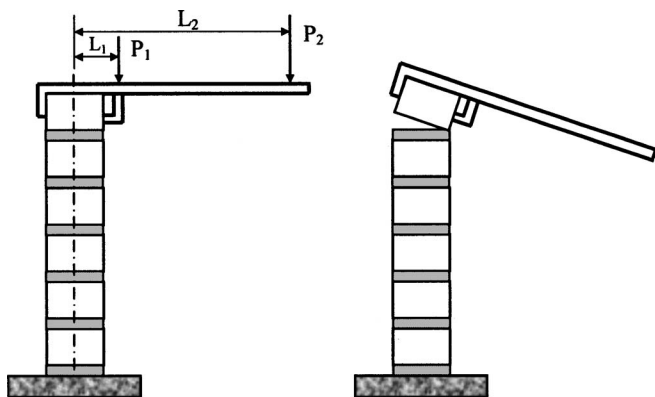

Fig. 2. Bond wrench shown in position before test and after bond failure

used. For the direct pure tensile test, they used bolts through the brick thickness to apply the load (Fig. 3). They concluded that a direct tensile test is more likely to produce a representative value for bond strength than a bending or wrench test, provided that a stress multiplication factor is applied to the average failure stress value obtained. The stress multiplication factor accounts for the difference between the average and maximum stress across the joint, as indicated by a finite-element analysis for the particular loading arrangement (Jukes et al. 1997).

Held and Andersen (1994) used crossed couplet specimens to

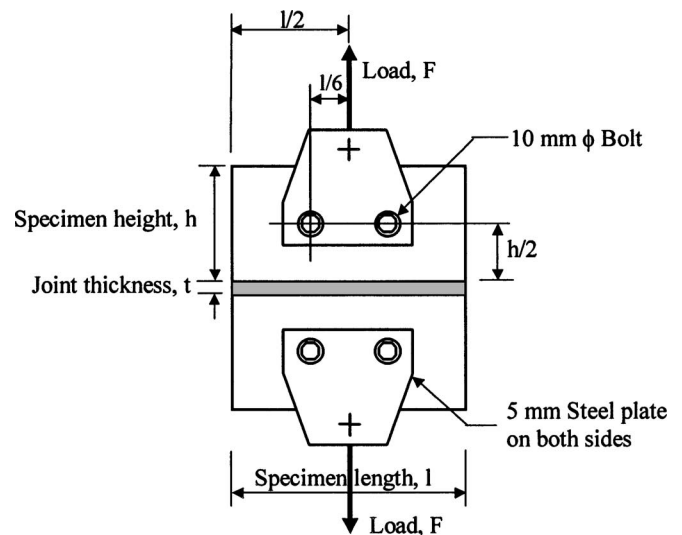

Fig. 3. Direct tensile test as performed by Riddington and Jukes (1994)

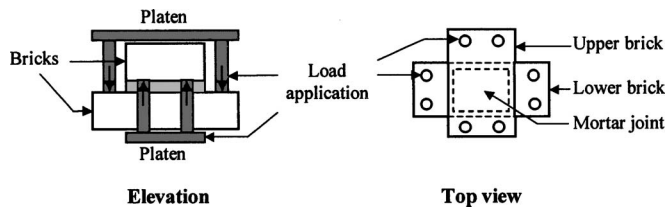

Fig. 4. Crossed couplet test specimens after Held and Andersen (1994)

establish bond strength. Failure was induced without pulling the specimen (Fig. 4).

Adams and Hobbs (1994) and De Vekey et al. (1990) compared results from several crossed-couplet tests with those found from wallettes (small walls) tested in accordance with BS 6528 (British 1992). In general, results from the wallettes were higher than those from the crossed-couplet tests (Fig. 5).

Sinha (1967) conducted direct tensile tests to determine bond strength. Sinha's results, while suffering from a high degree of variability, show a variation in the tensile bond strength as the moisture content of the mortar varies. The bond strength tends to increase for wetter mortars, until the saturation moisture content is approached, when strength falls off rapidly.

The new test method presented in this paper is based upon some of the principles given previously. The specimen is constructed from two units in a Z-shaped configuration, and failure is induced by bending under three-point loading. Testing was carried out on one calcium silicate brick, three different types of clay brick, and three different types of mortar. The Z-shaped test specimens were found to be easy to construct and test, with results showing a good degree of consistency.

Experimental Procedure

Materials Used in Construction

The materials used in the construction of the Z-shaped specimens included one calcium silicate brick, three types of clay brick of different properties and perforations, and three types of mortar of different proportions and strengths: Type (i), 1:1/4:3; Type (ii), 1:1/2:5; and Type (iii), 1:1:6 (cement: lime: sand) proportions by volume. The four types of brick used had actual work sizes of 214×102×65 mm. All bricks used were dried under normal laboratory conditions for at least 5 days prior to building. The brick compressive strengths and water absorptions shown in Table 2 were determined in accordance with BS 3921 (British 1985) and ASTM C 67 (1989), except that only five specimens were used instead of 10.

Table 2. Brick Types Used in Construction of Z-Shaped Specimens (Means of 5)

Brick number	Brick type	Full-brick		Half-brick		Water absorption of units (5 h boiling)	
		compressive strength (MPa)	C.V. ^a (%)	compressive strength (MPa)	C.V. ^a (%)	(%)	C.V. ^a (%)
1	Calcium silicate solid-frogged	24	5.6	33	6.5	14.2	7.3
2	Clay solid-solid wire cut facing	92	6.6	106	7.8	6.0	3.2
3	Clay—10 hole perforated	81	3.3	84	7.3	6.2	4.7
4	Clay—5 slot perforated	53	5.8	65	7.3	4.9	7.8

^aC.V.=coefficient of variation.

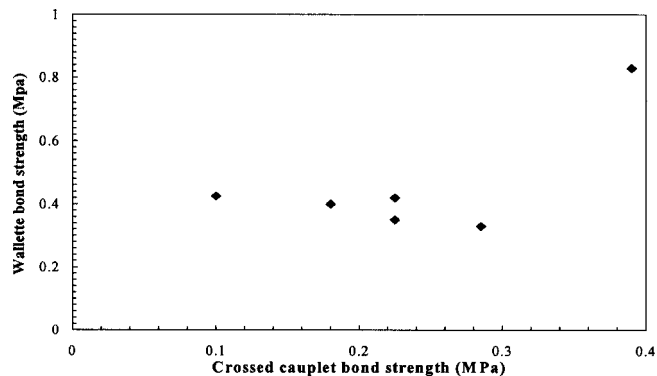

Fig. 5. Comparison of bond strengths from tests on wallettes and crossed couplets after Adams and Hobbs (1994) and De Vekey et al. (1990)

The three types of mortar used were as recommended by the British Masonry Standard BS 5628 (British 1992) for the construction of masonry walls. BS 5628 (British 1992) designated the mortar with the aforementioned volume proportions to Types (i), (ii), and (iii). The reason for choosing these mortar types was to study the effect of changing mortar proportions and strength on the flexural bond strength. The workability of the mortar was monitored using the dropping ball test described in BS 4551 (British 1998). In all cases, the workability was kept constant at a medium level within one mix and also for all other mixes of mortar used. The moisture content of the mortar at laying was recorded. The percentage water content by volume was calculated from the amount of water added during mixing. For each batch of mortar type used in the construction of the specimens, ten 100 mm cubes were cast to determine the compressive and splitting strength of the mortar. Table 3 summarizes the results for the three types of mortar used in the investigation.

Construction of Specimens

The specimens were constructed with two bricks bonded together by a 10 mm rectangular mortar joint in a staggered arrangement to try to reproduce the way in which brickwork is constructed on site (Fig. 6). The first brick was placed on the ground and against a timber block that was thicker than the brick by 10 mm. More than the needed amount of mortar was placed on the top face of the brick with a trowel. The second brick was then placed with half of it supported by the timber block and the other half by the mortar. The second brick was then tapped with a wooden mallet and leveled in two directions with a spirit level to create a 10-mm-thick mortar joint. The excess mortar squeezed to the sides was removed with a trowel, and the sides of the mortar joint were

Table 3. Mortar Types Used in Construction of Z-Shaped Specimens (Means of 5)

Mortar type (C:L:S) ^a	Mortar designation	Moisture content (%)	Penetration of dropped ball (mm)	Compressive strength (MPa)	C.V. ^b (%)	Splitting strength (MPa)	C.V. ^b (%)
1:1:6	Type (iii)	11.80	18.40	7.8	5.5	0.88	5.8
1:1/2:5	Type (ii)	11.74	20.81	11.2	4.5	1.24	5.4
1:1/4:3	Type (i)	12.05	19.50	22.2	3.4	2.82	4.4

^aC:L:S=cement: lime: sand by volume.

^bC.V.=coefficient of variation.

flattened level with the bricks from all sides. A 5 kg weight was placed on each specimen after laying in order to produce a pre-compression of 0.005 MPa. There was no particular reason for choosing this stress apart from preventing the two bricks from separating by accident in the early stages and to standardize the construction procedure. The timber block was left in place for 5 days, to allow the mortar to gain in strength. During these 5 days, the specimens were covered with thin plastic sheeting for curing. After the 5 days of initial curing, the plastic sheeting and timber block were removed. On removal, the writer noticed that there was no shrinkage cracks on the specimens. The specimens were then left for an additional 23 days to cure under ambient conditions in the laboratory before testing at 28 days from construction.

Preparation and Testing of Specimens

Six Z-shaped specimens of each brick/mortar combination were constructed and cured for 28 days. Before testing, the length of the mortar joint was recorded. Fig. 7 shows the loading and support arrangements used for testing the Z-shaped specimens. Plaster of Paris was used as a packing material at the loading to

support 10 mm² steel bars. Once the dental plaster was hardened, the specimens were loaded to failure by applying the load at a standard displacement rate of 1 mm/min.

Calculation of Bond Strength

The derivation of the theory to calculate bond strength is based on the assumption that the brick-mortar bond remains intact up to the point of failure, when a hinge occurs at the right-hand side of the mortar joint, under the applied load.

The following paragraphs describe the derivation of the equations used to calculate the flexural bond strength, f_{fb} .

Fig. 8 shows the external forces on the Z-shaped specimen. The reaction at the left-hand support (R_A) can be calculated by taking moments about the right-hand support, which are assumed to be simply supported:

$$R_A = \frac{0.5 l_b P + (1.5 l_b - t_{bar}) W}{1.5 l_b - t_{bar}} \quad (1)$$

For determining the values of the flexural bond strength, f_{fb} , two assumptions were used for the distribution of bond stresses at the brick-mortar interface. These are: (1) linear stress distribution; and (2) parabolic stress distribution.

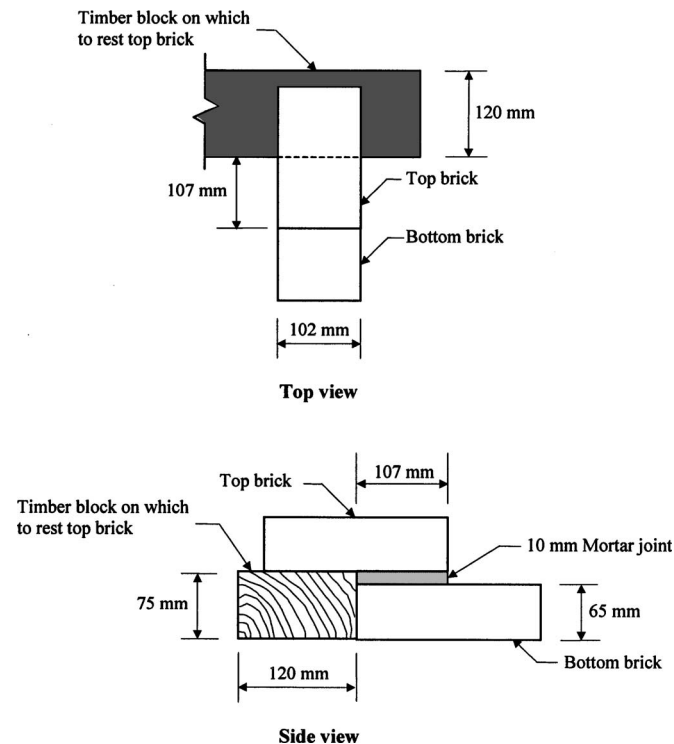

Fig. 6. Construction of Z-shaped specimens

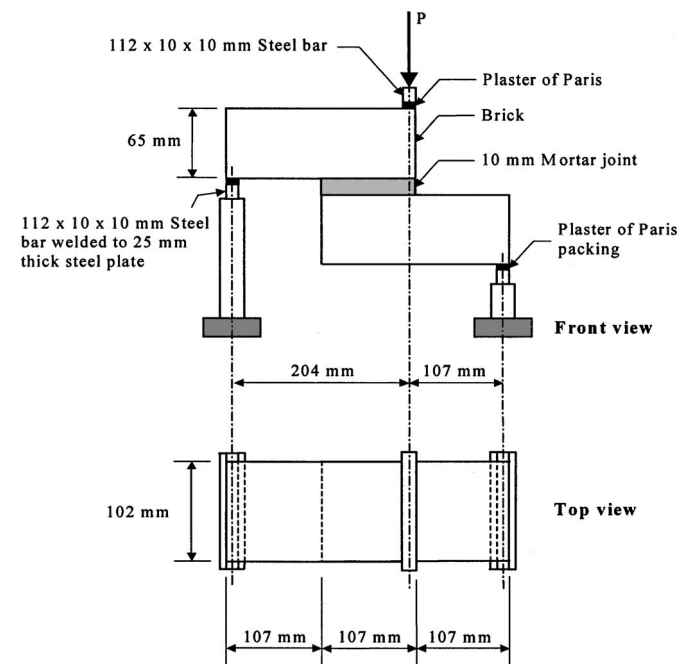

Fig. 7. Test setup for Z-shaped specimens

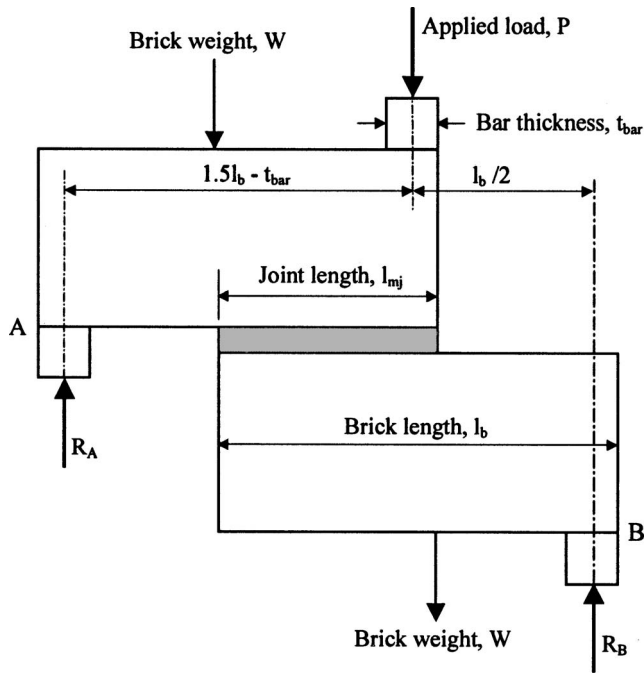

Fig. 8. Free body diagram of Z-shaped specimen showing applied forces and reactions

Linear Stress Distribution

At failure, the free body diagram of the top brick forces, which is shown in Fig. 9, applies. F_{fb} , the total force represented by the stress distribution, is calculated from the area of a triangle:

$$F_{fb} = 0.5(l_{mj}f_{fb}w_b) \quad (2)$$

By taking moments about the hinge (point H) (Fig. 9), assuming that the resultant moment is zero, the flexural bond strength can be calculated as follows:

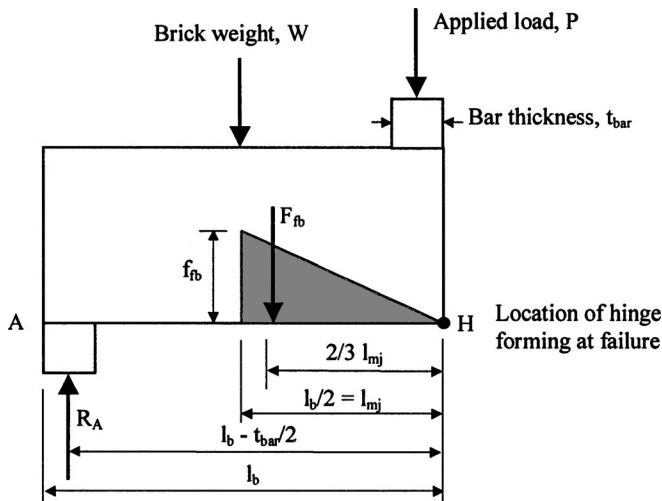

Fig. 9. Free body diagram of top brick showing forces and linear stress distribution

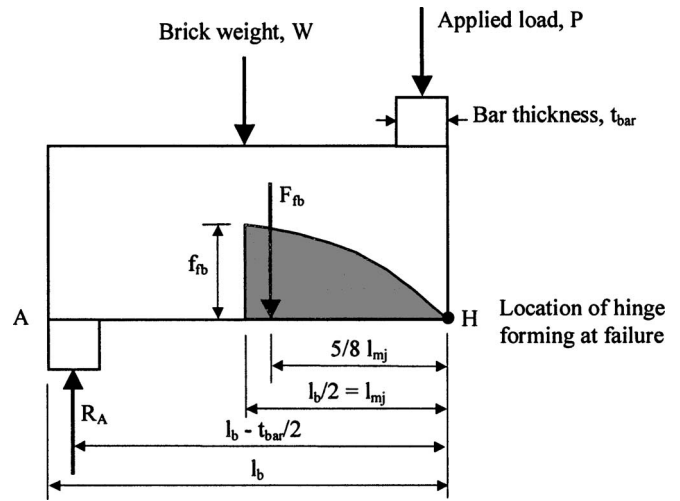

Fig. 10. Free body diagram of top brick showing forces and parabolic stress distribution

$$R_A(l_b - 0.5 t_{bar}) = 0.5l_b W + 0.667l_{mj}F_{fb} + 0.5t_{bar}P \quad (3)$$

By substituting for R_A and F_{fb} using Eqs. (1) and (2) and solving for f_{fb} , the bond strength is obtained using the following expression:

$$f_{fb} = \frac{(0.5l_b^2 - l_b t_{bar} + 0.5t_{bar}^2)P + (0.75l_b^2 - 1.25l_b t_{bar} + 0.5t_{bar}^2)W}{(0.333l_{mj}^2 w_b)(1.5l_b - t_{bar})} \quad (4)$$

For the dimensions and weights of bricks used in the series described in this investigation, $a=204$ mm; $b=107$ mm; $W=30$ N; $l_b=214$ mm; $l_{mj}=107$ mm; $t_{bar}=10$ mm; and $w_b=102$ mm. Therefore:

$$f_{fb} = 1.72 \times 10^{-4} P + 7.85 \times 10^{-3} \quad (5)$$

Parabolic Stress Distribution

It is possible to calculate a value of the flexural bond strength, f_{fb} , on the basis of a parabolic stress distribution (Fig. 10). F_{fb} , the resultant bond force, is calculated from the area of a parabola:

$$F_{fb} = 0.667(l_{mj}f_{fb}w_b) \quad (6)$$

$$f_{fb} = \frac{(0.5l_b^2 - l_b t_{bar} + 0.5t_{bar}^2)P + (0.75l_b^2 - 1.25l_b t_{bar} + 0.5t_{bar}^2)W}{(0.42l_{mj}^2 w_b)(1.5l_b - t_{bar})} \quad (7)$$

Using the same reasoning, dimensions and weights of bricks, and methods of calculations as described for the linear stress distribution, the relationship for the dimensions used in the series can be found:

$$f_{fb} = 1.36 \times 10^{-4} P + 2.1 \times 10^{-4} \quad (8)$$

Table 4. Results of Flexural Bond Strength by Mortar Type (Means of 5 or 6)

Brick number	Description	Mortar type (C:L:S) ^a	Failure load (N)	f_{fb} linear (MPa)	f_{fb} , parabolic (MPa)	C.V. ^b (%)
1	Calcium silicate solid-frogged	1:1:6	637	0.12	0.10	14
2	Clay solid-solid wire cut facing	1:1:6	2,552	0.45	0.35	21
3	Clay—10 hole perforated	1:1:6	1,757	0.31	0.24	18
4	Clay—5 slot perforated	1:1:6	1,896	0.33	0.26	21
1	Calcium silicate solid-frogged	1:1/2:5	818	0.15	0.11	15
2	Clay solid-solid wire cut facing	1:1/2:5	2,700	0.47	0.37	24
3	Clay—10 hole perforated	1:1/2:5	1,764	0.31	0.24	18
4	Clay—5 slot perforated	1:1/2:5	1,294	0.23	0.17	15
1	Calcium silicate solid-frogged	1:1/4:3	1,026	0.18	0.14	17
2	Clay solid-solid wire cut facing	1:1/4:3	3,172	0.55	0.43	19
3	Clay—10 hole perforated	1:1/4:3	1,895	0.33	0.26	16
4	Clay—5 slot perforated	1:1/4:3	1,587	0.28	0.22	14

^aC:L:S=cement: lime: sand by volume.

^bC.V.=coefficient of variation.

Results and Discussion

The results of the experimental test program are shown in Table 4. In this table, the values of flexural bond strength, f_{fb} , were derived using Eqs. (5) and (8). The table shows that the values of bond strength calculated using the parabolic stress distribution are lower than those derived using the linear stress distribution. For design purposes and to be on the safe side, it is more sensible to derive the bond strength values from the parabolic stress distribution rather than the linear, until future tests prove the opposite. The writer believes that the parabolic stress distribution is the more realistic state of bond stress at the brick-mortar interface as the specimen approaches failure.

Based on the values of f_{fb} calculated using the parabolic stress distribution, Table 4 shows that there is a slight increase in bond strength with increasing mortar strength. This is not true for Type 4 bricks (clay-5 slot). This could be due to a poor workmanship. Figs. 11 and 12 were plotted for brick Type 2 (clay solid wire cut) to show such an increase in best-fit line between the results. The results in Table 4 for clay solid wire cut brick shows that an increase in cube strength from 7.8 to 22.2 MPa causes an increase in bond strength from 0.35 to 0.43 MPa (23%).

Table 4 also shows that the values of f_{fb} for calcium silicate bricks are lower than those for clay bricks. This was primarily due to the smoothness of the surface of calcium silicate bricks as compared to clay bricks. The results for clay bricks showed solid wire cut bricks providing a better bond to the mortar than perforated bricks.

This was due to the loss of bonding area to the mortar caused by the presence of perforations.

The location of failure was also noted during the course of testing. Failure was most common (75% of cases) on the upper face of the joint. It was thought that this was because the lower face of the mortar joint is in a more favorable position for developing a good bond during laying and curing than the upper face. On the lower face, gravitational forces would tend to assist the flow of mortar into both small pores and larger voids, while these same gravitational forces would be working against the mortar on the top brick face. In no case did failure occur at both brick-mortar interfaces.

Table 5 shows the results of bond strength obtained from the present test program based on the parabolic stress distribution, from BS 5628 (British 1992) on small walls (wallettes), and from previous tests by other authors for type (iii) 1:1:6 mortar mix only. The values derived from BS 5628 (British 1992) are the characteristic flexural bond strengths for masonry, f_{kx} , for walls subjected to horizontal forces applied parallel to the bed joints (Table 1). The BS 5628 (British 1992) value for flexural bond strength of calcium silicate bricks ($f_{kx}=0.30$ MPa) looks higher as compared to the value determined from the present study ($f_{fb}=0.09$ MPa) and also as compared to the value derived by Held and Anderson (1983) for crossed couplet ($f_{fb}=0.22$ MPa) and Riddington and Jukes (1994) ($f_{fb}=0.20$ MPa) for direct tension (Table 5). For clay bricks with water absorption <7% built with mortar type (iii), the British

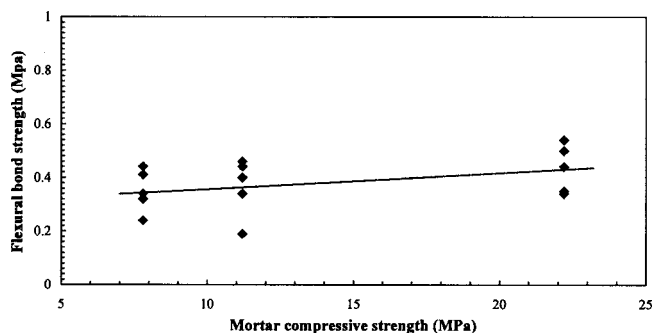

Fig. 11. Flexural bond strength versus mortar compressive strength

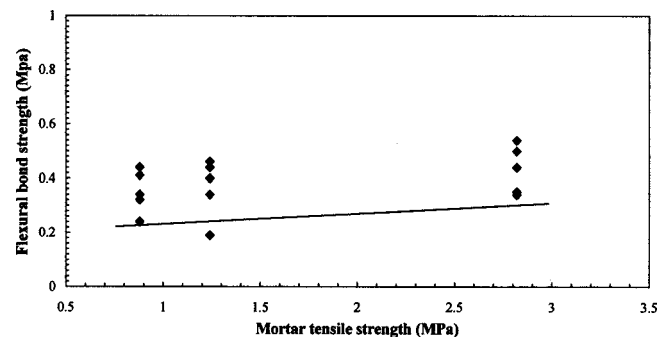

Fig. 12. Flexural bond strength versus mortar splitting strength

Table 5. Values of Bond Strength from Various Sources for 1:1:6 (C:L:S) Mortar Mix

Authors	Brick description	Water absorption of units (5 h boiling) (%)	Test type	Bond strength (MPa)	C.V. ^a (%)
Present investigation	Calcium silicate solid-frogged	14.2	Z-shaped	0.10	14
	Clay solid-solid wire cut facing	6.0	Z-shaped	0.35	21
	Clay—10 hole perforated	6.2	Z-shaped	0.24	18
	Clay—5 slot perforated	4.9	Z-shaped	0.26	21
f_{kv} , BS 5628 (British 1992)	Calcium silicate	—	Wallette failure parallel to bed joints	0.30	—
	Clay	Less than 7	Wallette failure parallel to bed joints	0.50	—
	Clay	Between 7 and 12	Wallette failure parallel to bed joints	0.40	—
	Clay	Over 12	Wallette failure parallel to bed joints	0.30	—
Held and Anderson (1983)	Calcium silicate	—	Crossed couplet	0.22	33
	Calcium silicate	—	Wallette	0.36	34
De Vekey et al. (1990)	Clay	—	Crossed couplet	0.28	35
	Clay	—	Wallette	0.33	48
Riddington and Jukes (1994)	Calcium silicate solid-frogged	13.9	Direct tension	0.20	31
	Clay solid-solid wire cut facing	6.2	Direct tension	1.04	16
	Clay solid-solid wire cut facing	6.2	Brick stack parallel	0.77	18

^aC.V.=coefficient of variation.

Standard value of flexural bond strength ($f_{kv}=0.50$ MPa) is higher than all the values derived from the Z-shaped specimens for bricks with water absorption $<7\%$ ($f_{fb}=0.24-0.35$ MPa). The nearest value to the BS 5628 (British 1992) was the one derived from the solid wire cut bricks ($f_{fb}=0.35$ MPa). However, the values of bond strength derived from the present test program for solid wire cut bricks and different mortar types ($f_{fb}=0.35-0.43$ MPa) are higher than the values derived from tests on specimens built with similar type of bricks carried out by De Vekey et al. (1990) ($f_{fb}=0.28$ MPa for crossed couplet and $f_{fb}=0.33$ MPa for wallettes). The results of f_{fb} derived from the present testing program for solid clay bricks showed low values as compared to the ones from tests by Riddington and Jukes (1994) ($f_{fb}=1.24$ MPa for direct tension and $f_{fb}=0.77$ MPa for brick stack parallel).

Finally, it was observed from the results in Tables 4 and 5 that the coefficients of variation (C.V.), which are a reflection of the variability in the test results, for the values of f_{fb} derived by testing the suggested Z-shaped specimen were not very high (between 14 and 24%) as compared to the C.V. values presented by the other authors referenced in this paper. This was primarily due to the following:

1. Deriving the flexural bond strength from the proposed specimen by bending reduces or even eliminates any eccentricities caused by the awkward setup and loading of small test walls (wallettes), crossed couplets, direct tension, or other types of specimen.
2. Because the bond failure in the proposed specimen occurred at a single brick-mortar interface, the variation in results will be lower than if the failure were at two or more interfaces, as is the case with the BS 5628 (British 1992) wallettes test specimens.
3. Due to the small size of the Z-shaped specimens, the preparation and loading are easy to line up and conduct without the need to move and set up large specimens, as is the case with the BS 5628 wallettes test specimens.

Conclusions

The following conclusions can be made from the work presented in this paper:

1. The proposed new Z-shaped specimen provides an easy test to derive f_{fb} by three-point loading, whereby failure of the brick-mortar interface is caused by flexure rather than by direct tension, as is the case with a pull test specimen. The results also show that the proposed Z-shaped specimen is capable of determining the values of flexural bond strength, f_{fb} , for brickwork where the plane of failure is parallel to the bed joints.
2. A general expression was derived and given in Eqs. (4) and (7) for the calculation of the brick-mortar flexural bond strength, f_{fb} , from tests on Z-shaped specimens of varying brick types, weights, dimensions, materials, water absorption, etc. The equations for deriving the brick-mortar flexural bond strength, f_{fb} , are based upon firstly a linear and secondly a parabolic stress distribution.
3. From the results of bond strength, it is clear that the values derived using the parabolic stress distribution are lower than the values derived using the linear stress distribution. Therefore, for design purposes and to be on the safe side, calculation of the flexural bond strength should be based on the parabolic stress distribution until more tests prove the opposite.
4. Results of the test showed that the perforated bricks gave lower values of f_{fb} than the solid wire cut bricks. This was attributed to the loss of bonding area to the mortar caused by the presence of perforations.
5. From observations made during testing, it was found that failure occurred most commonly (75% of cases) on the upper face of the mortar joint. This was thought to be because gravitational forces aided the penetration of mortar into the brick on the lower face.
6. The tension failure in the proposed specimen occurred at a single brick-mortar interface rather than a few interfaces at

different bed joints, as is the case with the BS 5628 (British 1992) test specimen. This produced values of f_{fb} with a noticeable reduction in the coefficient of variation (C.V.) as compared to the results presented in this paper by other authors.

Notation

The following symbols are used in this paper:

- a = distance between load and left hand (LH) support (mm);
- B = base of parabola;
- b = distance between load and right hand (RH) support (mm);
- F_{fb} = total force of flexural bond stress distribution (N);
- f_{fb} = flexural bond strength (MPa);
- f_{kx} = characteristic flexural strength of masonry (MPa);
- H = height of parabola;
- L = lever arm for applied load on Brench (mm);
- L_1 = lever arm for mass of Brench plus clamping unit at center of gravity (mm);
- l_b = length of brick unit (mm);
- l_{mj} = length of mortar joint (mm);
- P = failure load (N);
- P_1 = force due to deadweight of apparatus plus clamping unit (N);
- P_2 = force at failure due to either lead shot or operator (N);
- R_A = reaction force at support point A (N);
- R_B = reaction force at support point B (N);
- t_{bar} = thickness of steel bar (mm);
- W = weight of brick (N);
- w_b = width of brick unit (mm); and
- μ = masonry orthogonal ratio
 $[f_{kx(\text{parallel})}/f_{kx(\text{perpendicular})}]$ (see Table 1).

References

Adams, M. A., and Hobbs, D. W. (1994). "Bond strength of brickwork from crossed couplet and walette tests: Some comparative results."

Mas. Inter., 8(1), 16–20.

ASTM. (1989). "Building brick: Solid masonry units made from clay or shale." *ASTM C62*, West Conshohocken, Pa.

ASTM. (2000). "Standard test method for measurement of masonry flexural bond strength." *ASTM C1072a*, West Conshohocken, Pa.

ASTM. (2002). "Standard test methods for evaluating masonry bond strength." *ASTM C1357*, West Conshohocken, Pa.

Australian Standards. (1998). "Masonry structures." *AS 3700*, Standard Australia International, Sydney, Australia.

British Standards Institution (BSI). (1985). "Specification for clay bricks." *BS 3921*, London.

British Standards Institution (BSI). (1992). "Use of masonry: Code of practice for use of masonry, unreinforced masonry." *BS 5628: Part 1*, London.

British Standards Institution (BSI). (1998). "Method of testing mortars, screeds and plasters: Physical testing." *BS 4551: Part 1*, London.

Building Research Establishment (BRE). (1991). "Testing bond strength of masonry." *Digest 360*, Garston, H.K.

De Groot, C. J. W. P. (1987). "Bond in masonry." *Proc., 5th Int. Conf. on Structural Engineering Analysis and Modeling*, University of Science and Technology, Kumasi, Ghana.

De Vekey, R. C., Edgell, G. J., and Dukes, R. (1990). "The effect of sand grading on the performance and properties of masonry." *Proc. Brit. Mason. Soc. (UK)*.

Grandet, B. (1975). "Physico-chemical mechanisms of the bond between clay and cement." *Proc., 3rd Int. Brick and Block Masonry Conf.*, H. Glitza and K. Göbel, eds., Bonn, Germany, 217–221.

Held, L., and Anderson, C. (1983). *The effect of sand grading on mortar properties and tensile bond*, South Bank Univ., London.

Hendry, A. W., and Khalaf, F. M. (2001). *Masonry wall construction*, E & FN Spon, London.

Jukes, P., Bouzeghoub, M. C., and Riddington, J. R. (1997). "Measurement of tensile strain softening and its influence on bond tensile test results." *Proc., 4th Int. Symp. on Computer Methods in Struct. Masonry*, G. N. Pande, J. Middleton, and B. Kralj, eds., E & FN Spon, London, 169–176.

Kamf, L. (1963). "Factors affecting bond between bricks and mortar." *Proc., Symp. on Masonry Testing*, ASTM, West Conshohocken, Pa., 127–141.

Lawrence, S., and Cao, H. T. (1987). "An experimental study of the interface between brick and mortar." *Proc., 4th North American Masonry Conf.*, Masonry Society, Boulder, Colo., 1–14.

Riddington, J. R., and Jukes, P. (1994). "A masonry joint shear strength test method." *ICE J.*, 104, 267–274.

Sinha, B. P. (1967). "Model studies relating to load bearing brickwork." PhD thesis, Univ. of Edinburgh, Edinburgh, U.K.