

IALA Recommendation

E-200-3

On

Marine Signal Lights

Part 3 - Measurement

Edition 1

December 2008



20ter, rue Schnapper, 78100
Saint Germain en Laye, France
Telephone +33 1 34 51 70 01 Telefax +33 1 34 51 82 05
E-mail - iala-aism@wanadoo.fr Internet - <http://iala-aism.org>

Document Revisions

Revisions to the IALA Document are to be noted in the table prior to the issue of a revised document.

Date	Page / Section Revised	Requirement for Revision

Recommendation on Marine Signal Lights

Part 3 - Measurement

(Recommendation E-200-3)

THE COUNCIL:

RECALLING the function of IALA with respect to Safety of Navigation, the efficiency of maritime transport and the protection of the environment;

RECOGNISING that for the adequate performance of marine signal lights, both their photometric and colorimetric parameters have to be ensured;

RECOGNISING ALSO that a great variety of light sources have been and are still being developed;

RECOGNISING FURTHER that there are many different methods and equipment for the measurement of light;

NOTING that defined standards for photometry and colorimetry should be used worldwide to ensure the quality of signal lights for mariners;

NOTING ALSO that this document only applies to marine Aid-to-Navigation signal lights that are installed after the publication date of this document;

NOTING FURTHER that there should be available laboratories, which are working according to this documentation, for all IALA members and other appropriate Authorities which could be operated by themselves, by other Authorities in the same country or another country, or by private companies;

CONSIDERING the proposals of the EEP Committee, their lights experts and the IALABATT / IALALITE working group;

ADOPTS the Recommendation on Marine Aid-to-Navigation Signal Lights in the annexes of this recommendation; and,

RECOMMENDS that National Members and other appropriate Authorities providing marine aids to navigation services carry out photometric and colorimetric measurements of Marine Aid-to-Navigation Signal Lights in accordance with this recommendation.

* * *

Table of Contents

DOCUMENT REVISIONS	2
TABLE OF CONTENTS	4
INDEX OF FIGURES	8
INDEX OF TABLES	9
ANNEX I Measurement	10
1 INTRODUCTION	10
2 SCOPE	11
3 OBJECTIVE	11
4 DEFINITIONS	11
4.1 Photometry	11
4.2 Colorimetry	12
4.3 Luminous Flux (lumen)	12
4.4 Solid Angle (steradian)	12
4.5 Luminous Intensity (candela)	13
4.5.1 Angular luminous intensity distribution	13
4.5.2 Time dependent luminous intensity distribution	14
4.5.3 Continuous Intensity (I_{cont})	14
4.5.4 Fixed Intensity	14
4.5.5 Maximum Intensity (I_{max})	14
4.5.6 Peak Intensity (I_o)	14
4.5.7 10th Percentile Intensity	14
4.5.8 Integrated Intensity (I_{int})	14
4.5.9 Effective Intensity (I_e)	14
4.6 Luminance (L)	14
4.7 Luminous Flux Density or Illuminance (lumen/m ² or lux) [31]	15
4.8 Beam Divergence	15
4.9 Flicker Fusion Frequency or Critical Flicker Frequency	16
4.10 Crossover Distance	16
4.11 Measurement Distance	16
4.12 Measurement Angle	16
4.13 Minimum Photometric Distance	16
4.14 RMS	16
4.15 Goniometer, Goniophotometer [19]	17
4.16 Chromaticity [24]	17
4.17 Spectral Distribution [14]	17
4.18 Spectral Power Distribution [14]	17
4.19 Hue	18

4.20	Colour Saturation	18
4.21	Chroma	18
4.22	Slew Rate	18
4.23	Spectral Mismatch Errors and Correction [6]	18
5	MEASUREMENT PRINCIPLES	19
5.1	Photometric Distance Law	19
5.2	Measurement of Angular Luminous Intensity Distribution	20
5.3	Recommended Measuring Planes	20
5.3.1	'Pencil beams'	20
5.3.2	'Fan Beams'	22
5.4	Colorimetry [24]	23
5.4.1	Tristimulus measurement	23
5.4.2	Spectral measurement	23
6	MODELS AND FUNCTIONS	24
6.1	Photopic Luminous Efficiency Function of the Standard Observer $V(\lambda)$ [16]	24
6.2	Scotopic Luminous Efficiency Function $V'(\lambda)$ [16]	24
6.3	Talbot-Plateau Law	25
6.4	Standard Colorimetric Observer [29]	25
6.5	Chromaticity [24]	26
6.6	Colour Temperature and Correlated Colour Temperature [24]	26
6.7	CIE Illuminant A [21]	27
7	MEASUREMENT EQUIPMENT	27
7.1	Photometer	27
7.2	Goniometer Type 1	29
7.3	'Folding' Mirror	29
7.4	Tristimulus Colorimeter [32]	30
7.5	Monochromator [14]	31
7.6	Spectroscope, Spectrometer, Spectroradiometer	31
7.6.1	Scanning or Stepping Spectroradiometer	31
7.6.2	Array-based Spectroradiometer	32
7.7	Calibrated Light Sources [30]	32
8	GENERAL LABORATORY PROCEDURES	32
8.1	Written Procedures and Documentation	32
8.2	Test Equipment Identification	32
8.3	Calibration and Traceability	32
8.4	Identification of Test Items	33
8.5	Items Under Test	33
8.6	Environmental Conditions	34
8.7	Power/Electrical Conditions	34

8.8	Equipment Warm-up	34
8.9	Stray and Ambient Light Control	34
8.10	Source/Data Identification	35
8.11	Power Monitoring of Item under Test	35
8.12	Recording System	35
8.13	Software	35
8.14	Errors, Uncertainty and Confidence	35
	8.14.1 Systematic Errors (Characterisation)	36
	8.14.2 Combined Standard Uncertainty	36
	8.14.3 Expanded Uncertainty	36
	8.14.4 Sampling Guidelines	36
8.15	Notes/Comments	36
8.16	Authorised Signatories	36
8.17	Retention of Data	36
9	PHOTOMETRY METHODS AND REQUIREMENTS	36
9.1	Standard Laboratory Photometry	36
9.2	Alignment	37
9.3	Photometric System Response; $V(\lambda)$ and $f'l'$	38
9.4	Spectral Correction	38
9.5	Measurement of Angular Dependency of Luminous Intensity [18]	38
9.6	Minimum Requirements for Angular Resolution	39
	9.6.1 Omnidirectional lantern—(fan beams)	39
	9.6.2 Directional and rotating beacons and precision projectors	39
9.7	Measurement of Time Dependency of Luminous Intensity	39
9.8	Minimum Photometric Distance	40
9.9	Measurement Aperture and Measurement Angle	42
9.10	Detailed Measurement Methods	42
10	COLORIMETRY METHODS AND REQUIREMENTS	43
10.1	Standard Laboratory Colorimetry	43
10.2	Alignment	43
10.3	Measurement System Spectral Response	44
10.4	Illumination of the Measurement Aperture	44
10.5	Considerations of Rapid Intensity Fluctuation of the Light Source	44
10.6	Minimum Measurement Distance	44
10.7	Detailed Measurement Methods	45
11	PRESENTATION OF RESULTS	45
11.1	Luminous Intensity versus Angle	45
	11.1.1 Main Values of a Symmetric Intensity Distribution	45
	11.1.2 Reduced Values for Type Testing or Type Approval	47
	11.1.3 Main values for Omnidirectional Beacons (fan beams)	47

11.1.4	Rotating Beacons (pencil beams)	48
11.1.5	Directional Beacons	48
11.2	Luminous Intensity versus Time	48
11.3	Flash Duration	49
11.4	Effective Intensity	49
11.5	Spectral Correction	49
11.6	Service Conditions Allowance	49
11.7	Light Colour	49
11.8	Sector Lights	50
11.9	Spectral Power Distribution	53
11.10	Nominal Range	53
11.11	Uncertainty & Confidence	53
12	REFERENCES	54
ANNEX II	Detailed Measurement Method	56
	ZERO-LENGTH PHOTOMETRY	56
1	INTRODUCTION	56
2	OFF-AXIS ZERO-LENGTH PHOTOMETRY	57
3	CALIBRATING OR CHARACTERISING THE ZERO-LENGTH SYSTEM	57
ANNEX III	Detailed Measurement Method	59
	OUTDOOR TELEPHOTOMETRY	59
1	INTRODUCTION	59
2	ADDITIONAL EQUIPMENT REQUIRED FOR OUTDOOR TELEPHOTOMETRY	59
2.1	Telephotometer	59
2.2	Reference Light	59
3	CALIBRATION PROCEDURES	60
4	ATMOSPHERIC CONDITIONS AND AMBIENT LIGHT	60
5	RECORDING ENVIRONMENTAL CONDITIONS	60
6	ALIGNING THE TELEPHOTOMETER	61
7	MEASUREMENT PROCEDURES FOR OUTDOOR TELEPHOTOMETRY	61
8	ADDITIONAL EQUIPMENT FOR ‘IN SITU’ MEASUREMENT	62
8.1	Prisms and Prism Frame	62
8.2	Reference Projector	62
9	ADDITIONAL PROCEDURES FOR “IN SITU” MEASUREMENT	64
9.1	Choice of Measurement Site	64
9.2	Setting Up the Telephotometer	64

9.3	Setting Up the Lighthouse Optic	64
9.4	Setting Up the Prism Frame and Prisms	64
9.5	Setting Up the Reference Projector	65
9.6	Carrying Out the Measurement	65
ANNEX IV	Detailed Measurement Method	66
	TRISTIMULUS COLORIMETRY	66
1	MEASUREMENT GEOMETRY	66
2	APPLICATION 1	67
3	APPLICATION 2	67
4	SPECTRUM	68
ANNEX V	Detailed Measurement Method	69
	SPECTRORADIOMETRY	69
1	MEASUREMENT GEOMETRY	69
2	CALIBRATION / CHARACTERISATION	69
3	CARRYING OUT THE MEASUREMENT	70
4	RESULTS	70
5	CONVERTING SPECTRAL DATA TO COLOUR AND CHROMATICITY	71
6	CONVERTING SPECTRAL DATA TO LUMINOUS INTENSITY	72
ANNEX VI	Example of a Photometry Uncertainty Budget	73
1	OUTDOOR PHOTOMETRY	73
2	ZERO-LENGTH PHOTOMETRY	73

Index of Figures

Figure 1	Solid Angle Geometry	13
Figure 2	Spectral Power Distribution of White LED (5nm intervals)	18
Figure 3	Spectral Plot showing Differences between Typical Photometer Response and $V(\lambda)$	19
Figure 4	Expanded Section of Spectrum Highlighting Photometric Error in figure 3	19
Figure 5	Photometric Distance Law	20
Figure 6	Measurement of Angular Distribution of Luminous Intensity	20
Figure 7	Horizontal Plane	21
Figure 8	Vertical Plane	21
Figure 9	Horizontal Plane of a Fan Beam	22
Figure 10	Vertical Plane of a Fan Beam	22
Figure 11	Tristimulus Principle	23
Figure 12	Spectral measurement	23
Figure 13	Photopic Luminous Efficiency Function $V(\lambda)$	24
Figure 14	Scotopic Luminous Efficiency Function $V'(\lambda)$	25
Figure 15	The CIE 1931 Standard Colour Observer	25

Figure 16	CIE 1931 Chromaticity Chart	26
Figure 17	CIE x, y Chromaticity Diagram showing the Planckian Locus	27
Figure 18	Measurement of Luminance	28
Figure 19	Type 1 Goniometer and Coordinate System.	29
Figure 20	Folding Mirror Schematic	30
Figure 21	Schematic of a simple Tristimulus Colorimeter	30
Figure 22	Schematic of Czerny-Turner Stepping Monochromator	31
Figure 23	Stray light reduction by absorbing screens	34
Figure 24	Arrangement to determine ambient and stray light	35
Figure 25	Crossover Distance	40
Figure 26	Measurement Angle	42
Figure 27	Symmetrical Intensity Distribution	46
Figure 28	Asymmetrical Intensity Distribution	46
Figure 29	Asymmetrical Intensity Distribution showing Reduced Values	47
Figure 30	Scatter plot of red LED beacon over 360°	50
Figure 31	Plot of chromaticity across the boundary between red and white sectors	51
Figure 32	As Figure 31 but plotted on a partial CIE 1931 Chromaticity Diagram	51
Figure 33	Method of Plotting Sector of Uncertainty on Intensity Graph	52
Figure 34	360 degree Plot of Sector Light showing Intensity and Chromaticity at 1° Intervals	52
Figure 35	Partial Plot of Sector Light shown in Figure 34 Plotted at 0.1° Intervals	53
Figure 36	Zero-Length Photometry System.	56
Figure 37	Zero-Length Geometry showing Angular Resolution	57
Figure 38	Off-Axis Zero-Length Geometry	57
Figure 39	The use of Prisms to Divert a Beam through a Vertical Angle	63
Figure 40	Standard arrangement	66
Figure 41	Simple Test for Setting Up Colorimeter	66
Figure 42	Beacon outside sphere	67
Figure 43	Beacon inside sphere	68
Figure 44	Spectroradiometer Measurement Geometry	69

Index of Tables

Table 1	Older units of luminance	15
Table 2	Older units of illuminance	15
Table 3	Example of a Spectroradiometer Correction File	70
Table 4	Results showing Conversion from SPD to X, Y, Z colour	71
Table 5	Results showing Conversion from SPD to Luminous Intensity	72

IALA Recommendation E-200-3

Marine Signal Lights

Part 3 – Measurement

ANNEX I MEASUREMENT

1 INTRODUCTION

This document is one of several parts dealing with aid-to-navigation signal lights and concerns their measurement, both photometric and colorimetric. Before bringing into service a new type of aid-to-navigation light, at least one equipment of each type shall be subjected to appropriate photometric and colorimetric measurements. These measurements shall provide information on the luminous intensity and colour of the light for substantially all directions within its zone of utilization. Measurements on flashing lights shall provide information on the variations of luminous intensity with time. The collated information from all measurements shall be used to assign the following for the equipment when deployed as an AtoN signal light:

- rhythmic character (as described in E-110);
- colour (as described in E-200-1);
- nominal range (as described in E-200-2).
- effective intensity (as described in E-200-4).

Manufacturers of marine signal lights may use the results of such measurements to provide a specification of product performance. Measurements may be carried out on equipment already in service to ensure continued quality of performance, both to the AtoN provider and the mariner.

In each country, the competent technical authority shall determine the appropriate measurements to be made for each type of aid-to-navigation light. Photometric and colorimetric methods shall be determined by the laboratory to which the task is assigned but, as an indication of the general principles to be followed, reference should be made to this document.

If possible, the photometric measurements should be made on a complete aid-to-navigation light as installed, including protective housing enclosing the optical system. To this end, measurements 'in situ' may be desirable. Measurements may also be made at suitable test sites, on a complete equipment, or on a source-optic combination without protective housing, and possibly also without colour filters intended for use in service. Such measurements, after correction for the effects of protective housing and of colour filters (where used), shall be applied to the actual equipment intended for subsequent installation, or to a light consisting of an identical source and operated under identical conditions to those of the aid-to-navigation light in question. The deduced effective intensity and luminous range may be taken as those of the installed aid.

The measurement of light is a complex subject and there is a danger that uninformed practitioners could achieve measurement results containing large errors of which they are unaware. Even when such errors are corrected or accounted for, the measurement result may still have a measurement uncertainty of several percent and in some cases tens of percent. Sometimes, such high uncertainties are unavoidable.

However, whatever measurement method is used, and whatever errors and uncertainties attained, it is important to properly evaluate them. The best way of doing this is by the use of an uncertainty budget. Properly used, this budget can be used, not only to determine uncertainty, but also to refine the measurement method by addressing dominant uncertainties. It should be remembered that no measurement result is complete without a statement of uncertainty and confidence.

2 SCOPE

This recommendation applies to the photometric measurement and characterisation of all marine aids-to-navigation signal lights. In general, the emissions provided by these signal lights may be categorized as ‘pencil beams’ or ‘fan’ beams.

Equipments used to generate pencil beams include searchlight-style or projector beacons, with single or multiple optics, and assemblies of “bulls-eye” lenses rotating about a common focal point. The peak fixed intensities provided by these beacons range from a few thousand to several million candelas, with beam spreads (as measured between the 50% intensity points) typically less than ten degrees in any cross section. Searchlight-style beacons may be fixed in position, to provide a *leading light* for marking a navigational channel, or may be rotated about a vertical axis to sweep the horizon and provide the appearance of a flashed light when viewed from a distance.

Anamorphic cylindrical lenses are typically used to generate fan beams. These lenses are usually made from Fresnel sections and can be drum or ‘beehive’ in shape. Such optics may be used to produce a uniform light signal about the horizontal plane (an omnidirectional signal). The signal may be blanked or coloured in one or more sections around the horizon, or may exhibit one or more areas of increased intensity by the use of condensing panels. The peak fixed intensities provided by these beacons range from a few tens of candelas to tens of thousands of candelas.

Light sources used in marine aids-to-navigation signal lights are typically incandescent lamps or discharge lamps. Light emitting diodes (LEDs) are increasingly being used, while acetylene open flame or gas-mantle light sources are becoming increasingly rare.

3 OBJECTIVE

The objective of this recommendation is to provide an approved methodology to promote uniformity in determining and reporting the optical performance of a diverse group of marine aids-to-navigation signal lights. Marine aids-to-navigation signal lights encompass projection-type equipment, using various light sources, lenses and mirrors, singly or in combination, and Fresnel-type drum lenses.

4 DEFINITIONS

The definitions in this section are not all encompassing. More complete and further definitions can be found in relevant CIE Publications [5], [6], [10], [14], [16], [17], [18], [19], [21], [24], [25], [26], [29], [30], [31], [32], [33], [34] and [35].

4.1 Photometry

Photometry is the measurement of electromagnetic radiation detectable by the human eye (visible light). The units of photometry can be derived from radiometric quantities (e.g. Watts) weighted by the luminous efficiency function of the human observer. The wavelength range of the spectrum concerned is typically taken between 380nm and 780nm.

The word **photometry** is derived from Greek: *phōtos* = light and *metron* = measure. It is the measurement of the visual aspect of radiant energy (visible light). As such, it is distinguished from radiometry in that photometry takes into account the varying sensitivity of the eye to different wavelengths of light. The units of photometry are luminous quantities that include luminous intensity, luminous flux, luminance and illuminance (see 4).

Wavelengths of light energy that can cause human visual sensation are typically from 380nm to 780nm. Wavelengths outside this range do very little to stimulate the human eye.

The eye itself, although a very sensitive and versatile receptor, is not a reliable indicator of luminous quantity. Therefore, in order to quantify the visible light seen by a human observer, it is necessary to carry out some form of measurement. This can be done by replacing the human observer with an instrument called a photometer (see 7.1). Although the spectral response of a photometer mimics that of the eye, it is colour-blind. So a photometer can quantify the amount of visible light but cannot indicate its colour.

4.2 Colorimetry

Colorimetry is the science of measuring colours. This could be the colour of a light source or the colour of a surface (e.g. red paint). The colorimetry of surface colours depends upon the illuminating light source, its angle of incidence, the viewing angle, surface texture and other variables. Only colours of light sources are dealt with in this document.

The word **colorimetry** is derived from Latin: *color* = colour and Greek: *metron* = measure. It is the science of measuring colour. There are broadly two types of colorimetry, the measurement of surface colours, such as painted metal, that are illuminated by incident light; and the measurement of light emitting objects, such as lamps.

The main focus of surface colorimetry has been the development of methods for predicting visual colour matching on the basis of physical measurements. The colorimetry of surface colours is not covered by this document.

The colorimetry of light sources is usually confined to describing colours as a series of numbers, typically as chromaticity coordinates giving the location of a point within a model of two-dimensional colour space (see 6.5). The resultant colour coordinates describe a colour, but not how bright the light is.

4.3 Luminous Flux (lumen)

Luminous flux is photometrically weighted radiant flux (power).

At a frequency of 540×10^{12} Hertz, it is defined as one lumen = 1/683 watts of radiant flux.

If a uniform point light source of one candela luminous intensity is positioned at the centre of a sphere of one metre radius, then every area of one square metre on the inside of that sphere will receive a luminous flux of one lumen (1 lm).

Since the surface area of a full sphere is 4π times the square of the radius, a uniform point light source of 1 cd therefore produces a **total** 12.57 lm of luminous flux. This **Total Luminous Flux** figure is often quoted by lamp manufacturers in their specifications. However, it should be remembered that most light sources are not uniform in their spatial distribution of light.

Standard unit of luminous flux is **Lumen (lm)**.

4.4 Solid Angle (steradian)

A **solid angle** is the angle that, seen from the centre of a sphere, includes a given area on the surface of that sphere. The value of the solid angle is numerically equal to the size of that area divided by the square of the radius of the sphere. For example, in a sphere of one

metre radius, a solid angle will describe an area of one square metre on the sphere's surface.

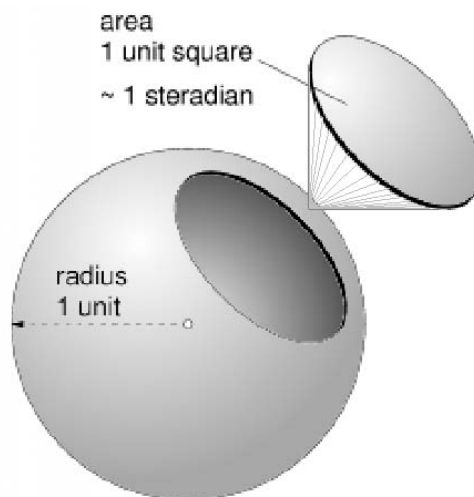

Figure 1 Solid Angle Geometry

Using the example of one candela at one metre distant, imagine a sphere of one metre radius with a point source of one candela at its centre. The illuminated surface area of the sphere over a solid angle of one steradian is one square metre. The luminous flux within that solid angle is one lumen. The illuminance incident on that surface is one lumen per metre squared or one lux.

4.5 Luminous Intensity (candela)

The **luminous intensity** is the luminous flux emitted from a point per unit solid angle into a particular direction.

Luminous intensity is the base unit for photometry and is defined as follows:

The candela is the luminous intensity, in a given direction, of a source that emits monochromatic radiation of frequency 540×10^{12} hertz and that has a radiant intensity in that direction of $1/683$ watt per steradian. [31]

Standard unit of luminous intensity is **candela (cd)**, also expressed as *lumen per steradian (lm/sr)*.

4.5.1 Angular luminous intensity distribution

The **angular luminous intensity distribution** is a function of the intensity depending on the direction. In general the direction is described by two angles (e.g. Θ and Φ). The intensity distribution becomes $I = I(\Theta, \Phi)$.

For many applications the intensity is restricted to a plane. The intensity distribution is then a function of one angle only $I = I(\Phi)$.

Maximum, average and 10th Percentile intensities can be read from an angular intensity distribution, as well as beam divergence angles.

4.5.2 Time dependent luminous intensity distribution

If the intensity I in a certain direction varies with time t the function $I(t)$ is called **time dependent luminous intensity distribution**.

Peak Intensity, integrated intensity and effective intensity can be read or calculated from a time dependent intensity distribution.

4.5.3 Continuous Intensity (I_{cont})

The intensity of a continuously burning light.

4.5.4 Fixed Intensity

Same as 4.5.3

4.5.5 Maximum Intensity (I_{max})

The maximum intensity in any given angular plot.

4.5.6 Peak Intensity (I_o)

The maximum value of instantaneous intensity reached within the time duration of a flash of light.

4.5.7 10th Percentile Intensity

The intensity exceeded by 90% of all intensity measurements within a given plot. The 10th percentile line is that which divides the lowest 10% and the highest 90% in any given population.

The 10th percentile intensity is used to describe the horizontal intensity distribution of an omnidirectional horizontal light (fan beam).

4.5.8 Integrated Intensity (I_{int})

This is the integral of instantaneous intensity with respect to time within a flash of light. With units of candela.seconds, this relates to a photometric quantity of energy:

$$I_{int} = \int I(t)dt$$

equation 1

4.5.9 Effective Intensity (I_e)

This is the intensity of a continuous light that gives the equivalent perception as that of a flash of light when viewed at the achromatic threshold of visual detection.

4.6 Luminance (L)

note: Photometric brightness is a deprecated term for luminance.

Luminous intensity per unit projected area of any surface, as measured from a specific direction. It is the physical measure of brightness.

Luminance (usually 'L' in formulas) is the amount of visible light leaving a point on a surface in a given direction. This "surface" can be a physical surface or an imaginary plane, and the light leaving the surface can be due to reflection, transmission, and/or emission.

Standard unit of luminance is **candela per square meter (cd/m²)**. (also called **Nits** in the USA, from Latin "nitere" = "to shine").

There are several older units of luminance that have now been superseded:

Table 1 Older units of luminance

Apostilb (deprecated)	1 asb	=	$1/\pi$ cd/m ²
Blondel (deprecated)	1 blondel	=	$1/\pi$ cd/m ²
Candela per square foot	1 cd/ft ²	=	10.764 cd/m ²
Candela per square inch	1 cd/in ²	=	1550 cd/m ²
Footlambert (deprecated)	1 fL	=	3.426 cd/m ²
Lambert (deprecated)	1 L	=	$10^4/\pi$ cd/m ²
Nit	1 nit	=	1 cd/m ²
Skot (deprecated)	1 skot	=	$10^{-3}/\pi$ cd/m ²
Stilb (deprecated)	1 sb	=	104 cd/m ²

4.7 Luminous Flux Density or Illuminance (lumen/m² or lux) [31]

note: Illumination is a deprecated term for Illuminance.

Luminous flux density is photometrically weighted radiant flux density, which means luminous flux per unit area at a point on a surface, where the surface can be real or imaginary.

Illuminance (usually 'E' in formulas) is the total amount of visible light illuminating, or incident upon, a point on a surface from all directions above the surface. This "surface" can be a physical surface or an imaginary plane. Illuminance is equivalent to *irradiance* weighted with the response curve of the human eye.

Standard unit for illuminance is **Lux (lx)**, or lumens per square meter (lm/m²).

There are also several older units of illuminance that have now been superseded:

Table 2 Older units of illuminance

footcandle	1 fc = 10.764 lx.
dalx (in Canadian safety regulations)	1 dalx = 10.764 lx.
phot	1 ph = 10,000 lx

A surface will receive lx of illuminance from a point light source that emits 1 cd of *luminous intensity* in its direction from a distance of 1 m. When using the non-standard US units, this translates into 1 fc received from a 1 cd source 1 ft away.

4.8 Beam Divergence

Beam Divergence (sometimes called beam spread) describes the angle between the two directions opposed to each other over the beam axis. Limits of divergence are set where the luminous intensity falls to a certain fraction of that of the maximum intensity within the beam. For aid-to-navigation beacons, horizontal and vertical divergences are usually quoted.

When used to describe the **vertical** spread of a beam, the vertical divergence is usually given two angles, upper and lower. These are given plus and minus figures respectively in accordance with measurement geometry (see 11.1.1)

It is normal practice to quote the angle between the two directions opposed to each other over the *beam axis* for which the *luminous intensity* is half that (50%) of the maximum luminous intensity (sometimes referred to as the *Beam Angle*). The angle between these 50% points is some times called full-width at half maximum—FWHM. It is recommended that FWHM is used when quoting beam divergence

Sometimes, the angle between the two directions opposed to each other over the *beam axis* for which the *luminous intensity* is one-tenth that (10%) of the maximum luminous intensity (sometimes referred to as the *Field Angle*) is quoted. The angle between these 10% points is some times called full-width at tenth maximum—FWTM. When FWTM is used instead of FWHM, it should be clearly stated.

When the luminous intensity points are other than half of maximum, the fraction or percentage of maximum should be quoted.

4.9 Flicker Fusion Frequency or Critical Flicker Frequency

This is the frequency above which the human eye perceives a flickering light source to be steady. Humans have a flicker fusion frequency of only 60Hz in bright light and 24Hz in low light.

4.10 Crossover Distance

This is the distance at which a beam of light is fully developed; where the divergent rays from the extremities of the optical aperture meet (see Figure 25). At this distance, the image of the light source will fully fill the aperture of the optical apparatus.

4.11 Measurement Distance

The physical distance between the light source being measured and the aperture of the measuring instrument. Where a curved mirror are being used, as in Zero-Length Photometry (see ANNEX II) the effective measurement distance may be different from the physical distance between light source and measuring instrument.

4.12 Measurement Angle

The angle subtended by the measurement aperture over the measurement distance (see 9.9).

4.13 Minimum Photometric Distance

The minimum photometric distance is the minimum distance between the beacon and the photoreceptor needed to ensure a certain accuracy for the measurement.

The minimum photometric distance depends on the required accuracy, the beacon and the photometer. In many cases an exact definition cannot be stated.

In some cases the crossover distance can be used as the minimum photometric distance (see 9.8).

4.14 RMS

The root mean square or rms is a statistical measure of the magnitude of a varying quantity. It can be calculated for a series of discrete values f_i or for a continuously varying function $f(t)$. The name comes from the fact that it is the square root of the mean of the squares of the values.

When $f(t)$ is a function of time then the root mean square for a time interval $[t_1, t_2]$ is:

$$RMS = \sqrt{\frac{1}{(t_2 - t_1)} \times \int_{t_1}^{t_2} f^2(t) dt}$$

equation 2

When $f(t)$ is a discrete function f_i for equally spaced times $t_i = i \cdot \Delta t$ then the integral can be replaced by a sum

$$RMS = \sqrt{\frac{1}{N} \times \sum_{i=0 \text{ to } N} f_i^2}$$

equation 3

Where:

$$N \cdot \Delta t = t_2 - t_1$$

It is recommended to use the RMS-value for electrical voltage, current and power, when a beacon has AC power supply.

4.15 Goniometer, Goniophotometer [19]

A goniometer is an instrument used for measuring geometric angles. When such an instrument is combined with a photometer to measure luminous intensity against a geometric angle, the device is called a goniophotometer. The practice of measuring luminous values with reference to geometric angle is called goniophotometry.

4.16 Chromaticity [24]

Chromaticity is the aspect of colour that includes consideration of its dominant or complementary wavelength and purity taken together. It is usually quantified by plotting a point, given as two coordinates, in a two-dimensional colour model space. An example is a chromaticity chart or diagram (see 6.5).

4.17 Spectral Distribution [14]

Spectral distribution is the way in which the relative radiometric value of electromagnetic radiation varies with wavelength.

4.18 Spectral Power Distribution [14]

A spectral power distribution (SPD) curve shows the radiant power emitted by a light source at each wavelength or band of wavelengths over the electromagnetic spectrum. For colorimetry and photometry the limits of the spectrum are typically 380 to 780 nm (visible light). The SPD may be weighted by \bar{x} , \bar{y} and \bar{z} colour functions to obtain tristimulus (X, Y and Z) colour values (see 6.4). The resultant X, Y, Z values can be further reduced to two x, y values and used as coordinates on a two-dimensional colour chart, or they may be weighted by the $V(\lambda)$ function to obtain a photometric value of luminous flux or luminous intensity.

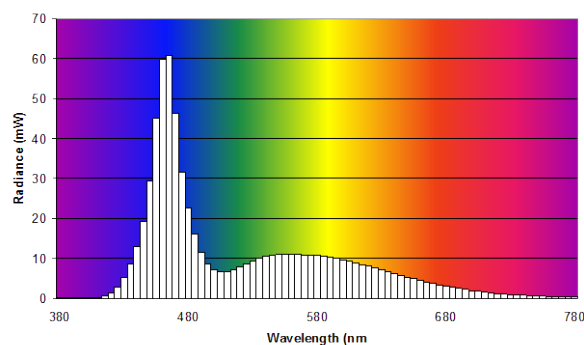

Figure 2 Spectral Power Distribution of White LED (5nm intervals)

4.19 Hue

The property of a colour by which it can be perceived as determined by the dominant wavelength of the light.

4.20 Colour Saturation

This is defined as chromatic purity, freedom from whiteness hence vividness of colour. A saturated colour will have a narrow spectral distribution and its chromaticity coordinate will lie close to the spectral locus of the chromaticity diagram (see 6.5).

4.21 Chroma

Short for "chrominance", it describes the attributes of a colour, which include its hue (wavelength) and saturation (lack of whiteness).

4.22 Slew Rate

The term is used to define the maximum rate of change of an amplifier's output voltage with respect to its input voltage. In essence, slew rate is a measure of an amplifier's ability to faithfully follow its input signal. Typically quoted as the time it takes the amplifier output to rise from 10% to 90% of its maximum output amplitude.

When considering the amplifier used in conjunction with a photometric detector, the ability of the amplifier to faithfully reproduce variations in intensity is important. Therefore, when measuring flashing lights where the instantaneous intensity varies quickly with time, the slew rate of the amplifier should be faster than the rise-time or fall-time of the flash profile.

Slew rate can be relevant for goniometers when intensity measurements are carried out whilst the goniometer is moving. It relates to the time interval between the angular steps, in other words, how long it takes the goniometer to move from one angular position to the next. The relationship between the time taken to carry out an intensity measurement and the speed of rotation of the goniometer can give an angular error.

4.23 Spectral Mismatch Errors and Correction [6]

Errors may occur when measuring a light source of different spectral distribution to the one used to calibrate the photometer because of differences between the spectral response of the photometer and the response of the standard photometric observer $V(\lambda)$. Such errors are called 'spectral mismatch errors' and can be quite large at certain wavelengths, typically in the red and blue regions where the photometer is least sensitive. Light sources with a narrow spectral distribution (e.g. coloured LED's) are more likely to produce large errors than broad-spectrum white light sources.

Spectral mismatch correction is an adjustment, carried out on the results of a photometric measurement, to correct any errors in the photometer spectral response.

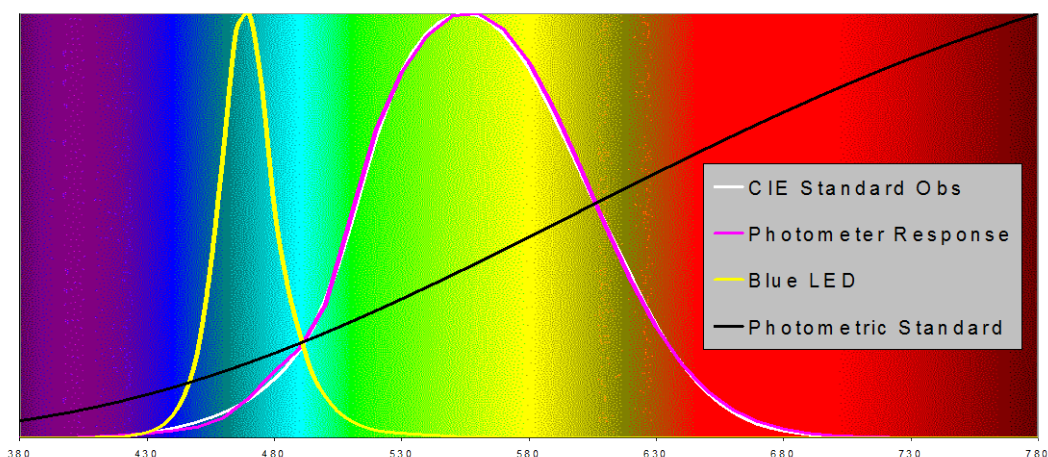

Figure 3 Spectral Plot showing Differences between Typical Photometer Response and $V(\lambda)$

-Example

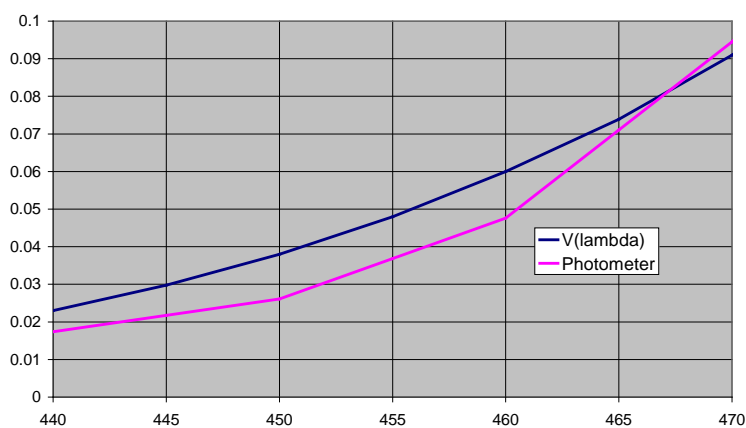

Figure 4 Expanded Section of Spectrum Highlighting Photometric Error in figure 3

- Example

5 MEASUREMENT PRINCIPLES

5.1 Photometric Distance Law

The measurement of luminous intensity is carried out by measuring the illuminance produced by a beacon a distance d away from a photoreceptor.

The luminous intensity is calculated by the Photometric Distance Law $I = d^2 E$.

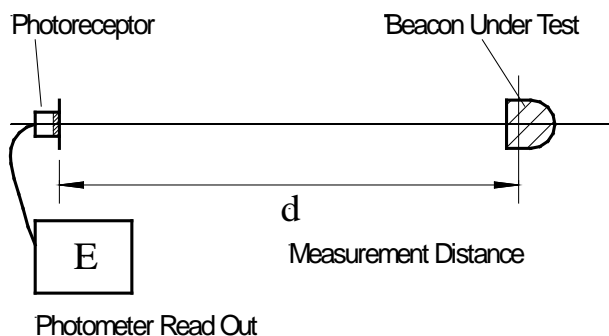

Figure 5 Photometric Distance Law

The arrangement above can be modified by introducing a folding mirror or by using Zero-Length Photometry (see ANNEX II).

5.2 Measurement of Angular Luminous Intensity Distribution

For signal lights the measurement of angular distributions can be carried out by rotating the beacon about two different axis. The intensity is a function of two angles $I = I(\alpha, \beta)$.

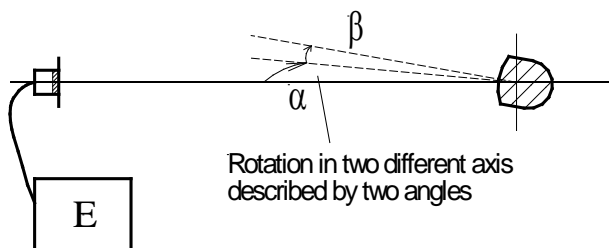

Figure 6 Measurement of Angular Distribution of Luminous Intensity

5.3 Recommended Measuring Planes

The measurement of the intensity distribution is often reduced to a number of planes. Within these planes the intensity distribution depends on one angle only. For Signal Lights, the recommended planes are horizontal and vertical planes.

5.3.1 'Pencil beams'

The reference axis of the beacon is usually in or near the direction with highest intensity and it should lie at the junction of vertical and horizontal planes. Therefore, the horizontal and vertical planes should include the reference axis (datum). All angles should be referenced to this axis.

- Horizontal plane:

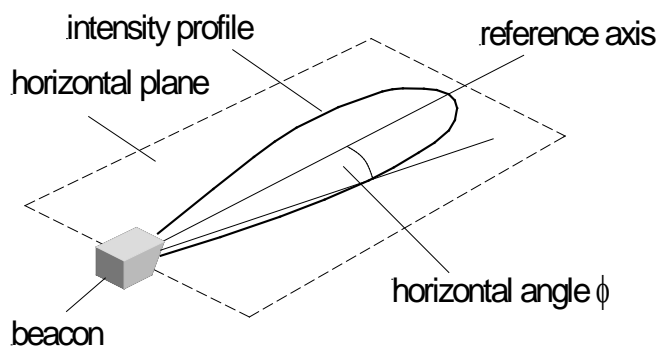

Figure 7 Horizontal Plane

- Vertical plane:

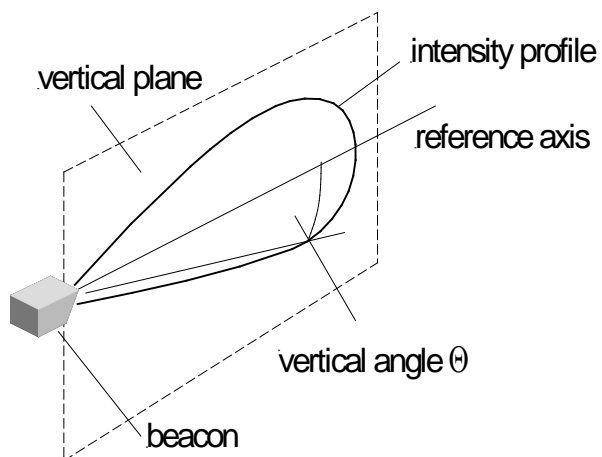

Figure 8 Vertical Plane

5.3.2 'Fan Beams'

- Horizontal plane:
In the horizontal plane a reference axis (datum) has to be defined. The selection of this axis is arbitrary because there is no preferred direction for the intensity. All angles are referenced to the axis defined.

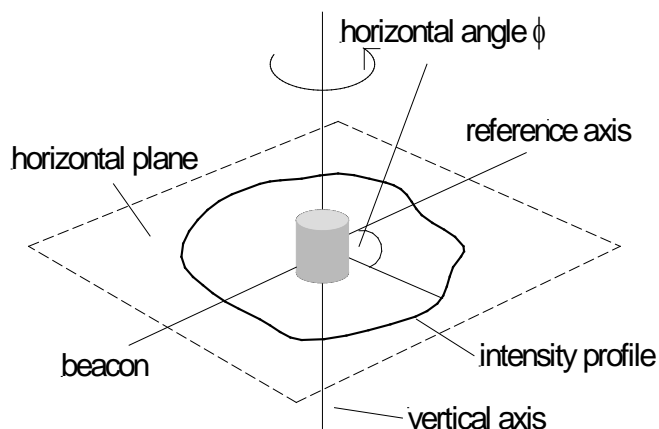

Figure 9 Horizontal Plane of a Fan Beam

- Vertical plane

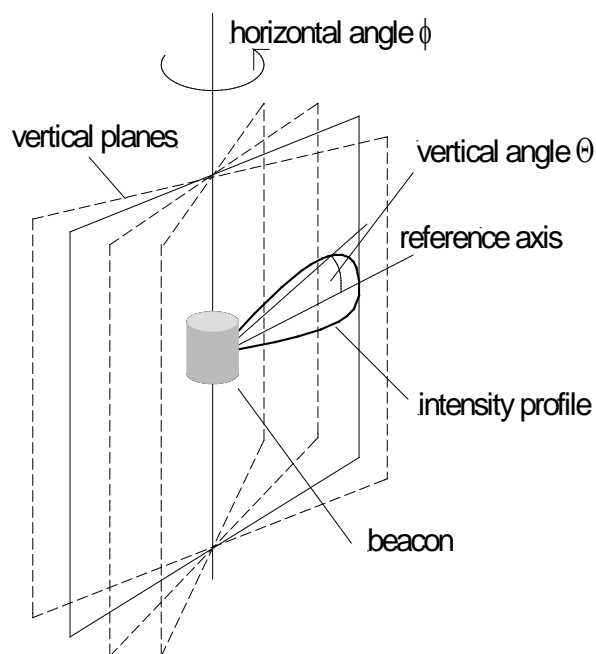

Figure 10 Vertical Plane of a Fan Beam

It is recommended to use more than one vertical plane. Each vertical plane is named by its horizontal angle from the horizontal reference axis.

For omnidirectional lights with one colour only, at least three planes should be measured (e.g. with horizontal angle $\phi = -120^\circ$, $\phi = 0^\circ$, $\phi = +120^\circ$).

For lights with coloured sectors measurements should be taken in at least one vertical plane per sector.

5.4 Colorimetry [24]

The colour of a signal light is described by chromaticity coordinates in accordance with CIE 1931 Standard Colorimetric Observer.

There are two main methods for the determination of chromaticity coordinates.

5.4.1 Tristimulus measurement

The light is passed through 3 different optical filters. Behind each filter a receptor measures the amount of light. Three different values are obtained. From these values the chromaticity coordinates can be calculated.

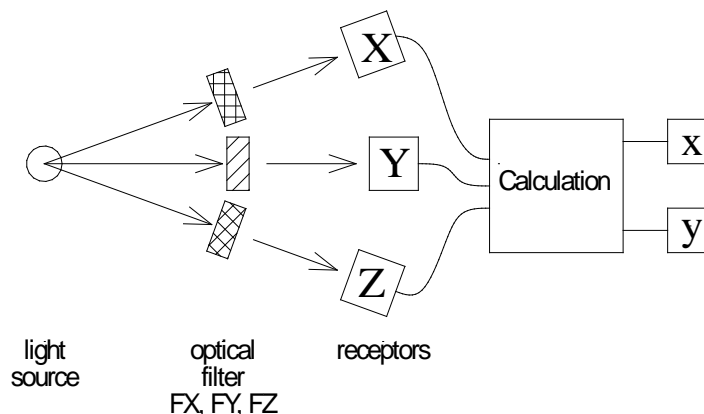

Figure 11 Tristimulus Principle

5.4.2 Spectral measurement

The light is split into different wavelengths. The amount of light for each wavelength or wavelength interval is measured by a receptor. The spectral values are used to calculate the chromaticity coordinates. If the splitting device is rotated the measurement can be done with a single receptor. The spectral values then are produced in temporal steps.

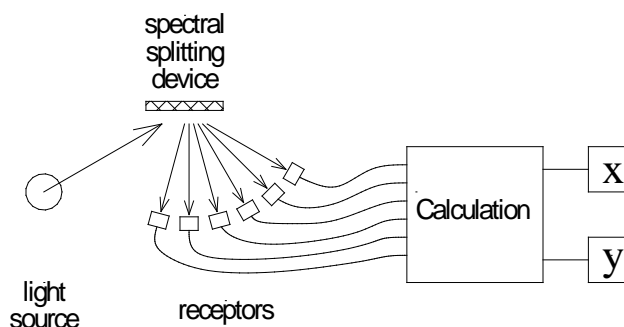

Figure 12 Spectral measurement

6 MODELS AND FUNCTIONS

6.1 Photopic Luminous Efficiency Function of the Standard Observer $V(\lambda)$ [16]

This is the spectral response of the average human eye in bright light using foveal vision (i.e. looking directly at an object). Developed by CIE in 1924 [5][16], it is sometimes called the CIE 2° standard photometric observer. It has a roughly Gaussian distribution with a peak wavelength of 555nm.

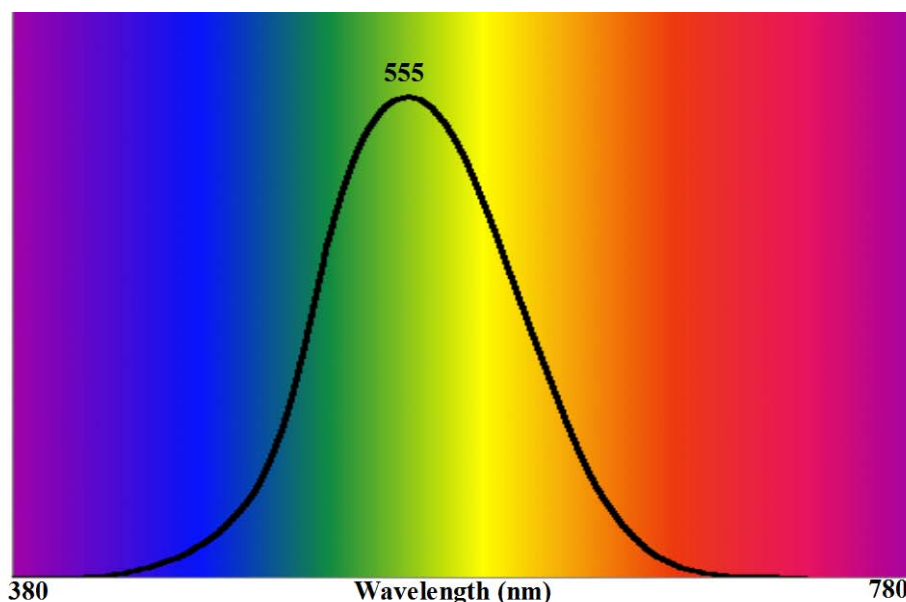

Figure 13 Photopic Luminous Efficiency Function $V(\lambda)$

It should be noted that the $V(\lambda)$ function should be used for the photometry of marine signal lights. If another visual scale, such as scotopic or mesopic, is used, this should be clearly stated.

6.2 Scotopic Luminous Efficiency Function $V'(\lambda)$ [16]

This is the spectral response of the average human eye with dark-adapted vision (below a luminance value of 0.034 lm/m^2). $V'(\lambda)$ has a similarly shaped response to $V(\lambda)$ but is shifted towards the shorter wavelengths, peaking at 505nm.

Scotopic vision means that there is no colour recognition.

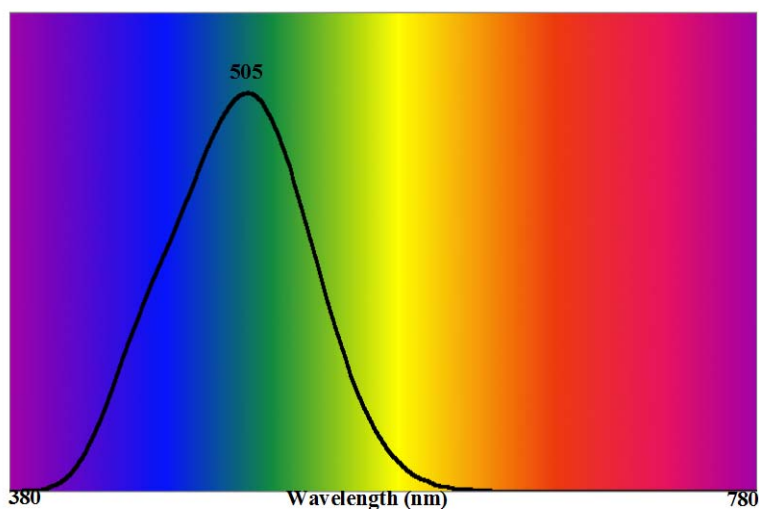

Figure 14 Scotopic Luminous Efficiency Function $V'(\lambda)$

6.3 Talbot-Plateau Law

The Talbot-Plateau Law states that if a light source is flashed or pulsed at a rate above the critical flicker frequency or flicker fusion frequency, such that it appears as a continuous light, the luminance of the source will be equal to that of a steady light that has the same time-average luminance [4].

When using high precision photometers, which typically have a low amplifier slew rate, to measure the continuous intensity of a light flickering or pulsing above the flicker fusion frequency, the photometer output may need to be time-integrated to ensure that the Talbot-Plateau Law is obeyed. For photometers with slower photoamplifiers, this may not be necessary.

6.4 Standard Colorimetric Observer [29]

In 1931, the CIE developed three colour matching functions labelled \bar{x} , \bar{y} and \bar{z} . These functions can be used to weight the spectral power distribution (SPD – see 4.18) of a light source in order quantify its colour.

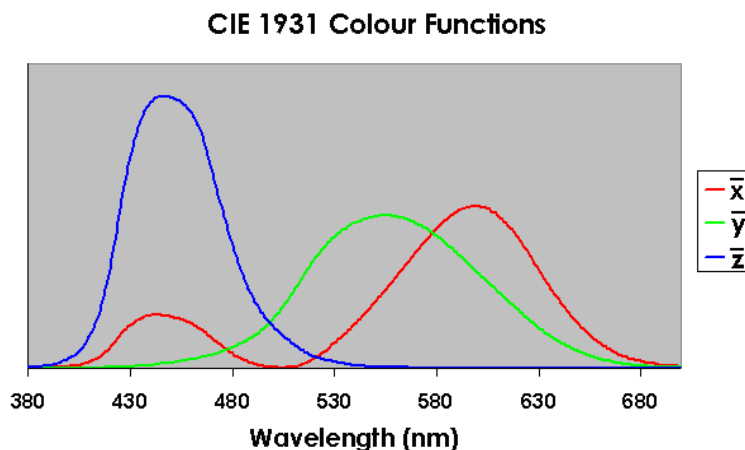

Figure 15 The CIE 1931 Standard Colour Observer

6.5 Chromaticity [24]

The resultant integrated quantities of a given SPD, when weighted by \bar{x} , \bar{y} and \bar{z} , are called X, Y and Z respectively. They can be reduced to two values in order to plot the colour of the light source on a two-dimensional x, y chromaticity chart, where:

$$x = \frac{X}{X + Y + Z}$$

equation 4

$$y = \frac{Y}{X + Y + Z}$$

equation 5

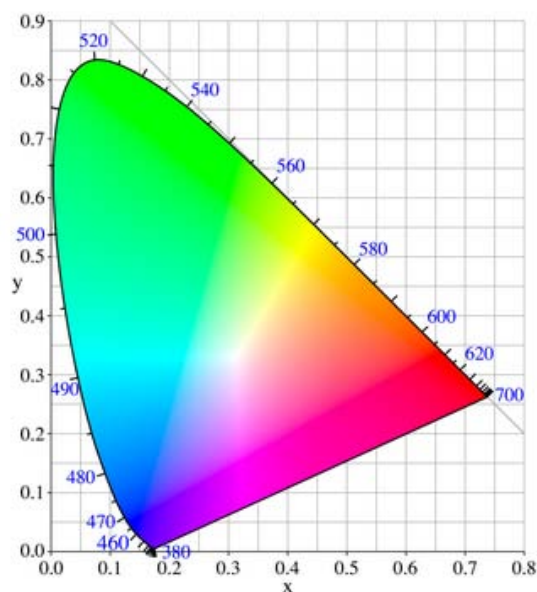

Figure 16 CIE 1931 Chromaticity Chart

The colour space is bounded by the spectral locus where monochromatic wavelengths are shown in units of nanometres (blue numbers). The CIE 1931 x, y chromaticity chart is the most commonly used for plotting the colour of light sources.

6.6 Colour Temperature and Correlated Colour Temperature [24]

The colour temperature of a traditional incandescent light source is determined by comparing its hue with a theoretical, heated black-body radiator. The lamp's colour temperature is the temperature in degrees Kelvin at which the heated black-body radiator matches the hue of the lamp.

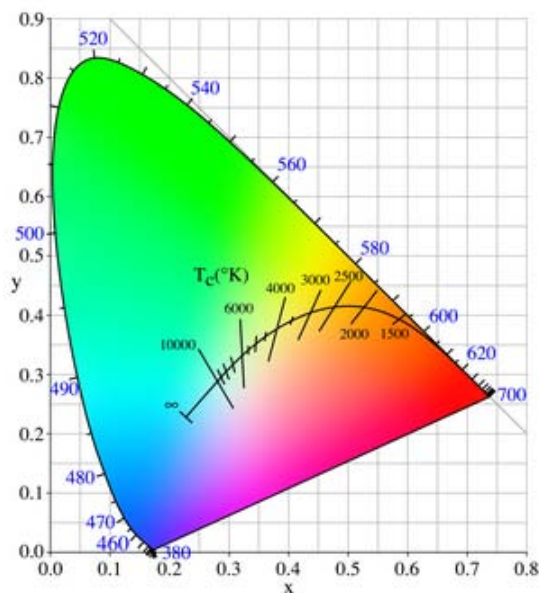

Figure 17 CIE x, y Chromaticity Diagram showing the Planckian Locus

The Planckian locus is the path that a black body colour takes through the chromaticity diagram as the black body temperature changes. Lines crossing the locus indicate lines of constant 'correlated colour temperature' (CCT).

6.7 CIE Illuminant A [21]

Illuminant A is often used as a reference light source to calibrate photometers. It has a spectral distribution of that of a theoretical black body at 2856°K. A tungsten filament lamp, run under the correct conditions, has a similar spectral distribution to that of Illuminant A.

There are other CIE illuminants used for reference purposes, such as illuminant D65 for daylight simulation in surface colour measurement but illuminant A is typically used for photometry and colorimetry of light sources. Further information on other illuminants should be sought from CIE.

7 MEASUREMENT EQUIPMENT

7.1 Photometer

Photometry, which is the measurement of visible light, is usually carried out with a measuring instrument capable of detecting light, usually by means of a photodetector, which converts incident photons to a proportionate electrical current. The electrical output of the photodetector is amplified to provide a readout that may be calibrated in a luminous value. Such a device is called a photometer.

A photometer may be calibrated in lumens per metre squared (lux) to measure the amount of light falling onto the surface of the photodetector (illuminance). Such a device is sometimes called a luxmeter.

The luxmeter is most commonly used for measurement on signal lights to determine the luminous intensity via photometric distance law.

$$I = d^2 E$$

equation 6

Where:

I is luminous intensity in candelas

d is distance in metres

E is illuminance in lumens per square metre (lux)

The output of a photometer may be calibrated to provide a readout in candelas using a known measurement distance and the above formula.

If the output aperture of the light-emitting device is restricted to a given area A_{emit} , the output of the photometer may be calibrated to provide a readout in candelas per metre squared (luminance). Such devices are called luminance meters and are useful for measuring the brightness of an emitting surface.

$$L = I / A_{emit}$$

equation 7

Where:

L is luminance in candelas per square metre

I is luminous intensity in candelas

A is area square metres

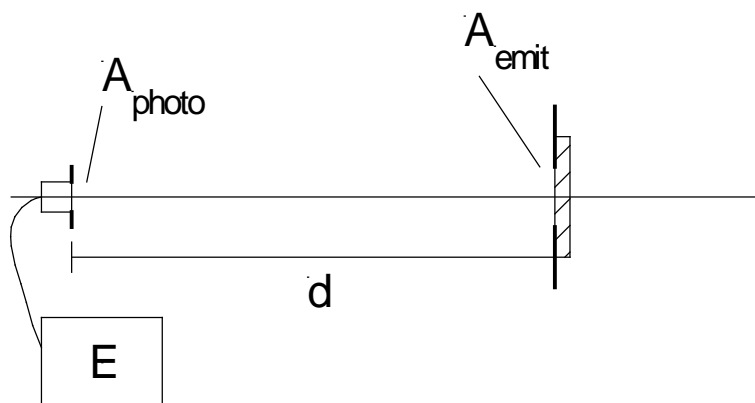

Figure 18 Measurement of Luminance

Use of a calibrated photometer is recommended. It would typically comprise a silicon photodiode, a $V(\lambda)$ -correction filter, and a precision aperture. Use of a calibrated detector, within the limits of the rated output, may eliminate the requirement to maintain calibrated sources. The light source reference for photometer calibration should be CIE Illuminant A.

A photometer used to measure flashing lights should have a temporal response fast enough to faithfully follow the temporal intensity profile. When analogue to digital (A/D) techniques are used to plot the time profile of a flash, the temporal response or integration time of the photometer should be similar to the sampling period to ensure that no gaps occur in recorded data.

The spectral response of the photometric system should closely approximate the spectral luminous efficiency curve $V(\lambda)$ for the CIE standard photometric observer in photopic vision (see 6.1). The calibration documentation for the photometric system should include the

spectral response values of the photometric detector from 380 to 780 nm, in increments no greater than 10nm. Most photometers are calibrated using Illuminant A (see 6.7), therefore when using a photometer to measure lights with spectral distributions different to Illuminant A (e.g. coloured lights or discharge lamps) care must be taken to avoid errors due to spectral mismatch (see 9.4).

7.2 Goniometer Type 1

In the interests of commonality, a type 1 goniometer is recommended for the angular measurement of marine signal lights. With a type 1 goniometer the source is tilted about a fixed horizontal axis and also turned about an axis which, in the position of rest, is vertical, and upon rotation follows the movement of the horizontal axis. Figure 19 illustrates a typical type 1 goniometer, and the loci traced by the goniometer in relation to the photocell. The related coordinate system to be used with the type 1 goniometer is described in CIE Publication No. 121 of 1996 [19]. If a goniometer of a type other than type 1 is employed, angular reference should be made to Figure 19.

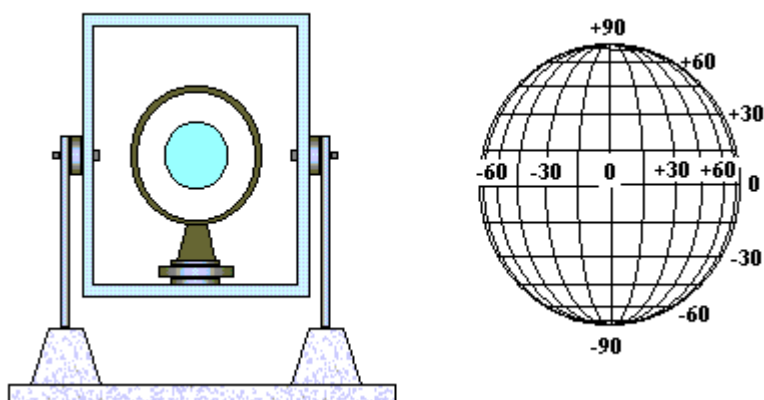

Figure 19 Type 1 Goniometer and Coordinate System.

A method of determining the uncertainty in the positioning mechanisms of the goniometer should be documented, and the stated uncertainty in angular displacement evaluated. It should be noted that when the goniometer table is tilted, the measurement distance from the top and bottom of the item under test changes and this can lead to a measurement error. This error may be corrected or treated as an additional uncertainty (see 8.14).

7.3 'Folding' Mirror

When the minimum photometric distance (see 4.11) exceeds the length of the measurement light path, a flat mirror, sufficiently large as to generate a full image of the item under test, may be placed at the end of the light path. The photometer may be used to measure the light signal reflected from the mirror.

It is recommended to use a front-surfaced mirror with a very accurate flat surface, high reflectance and flat spectral reflectance to minimize losses and geometrical distortion of the reflected image.

However the use of a mirror may result in a change to the spectral correction factor, SCF (see 9.4). Measurement of a reference source, directly and over the folded path, of similar spectral output to the item under test, may be used to determine overall losses and spectral distortion produced by the mirror. If the minimum measurement distance still exceeds the

folded measurement length, measurements should be made using one of the two methods described in ANNEX II and ANNEX III.

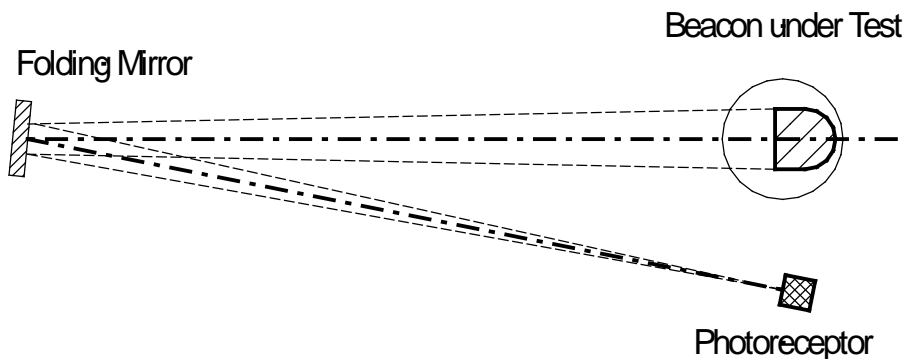

Figure 20 Folding Mirror Schematic

It is recommended that the photoreceptor be close to the beacon under test. For this the reflecting angle of the mirror is very small and the path between beacon and mirror equals approximately the path between the mirror and the photoreceptor.

Care must be taken to avoid stray light because the volume between mirror and beacon is strongly illuminated.

If the diameter of light output area of the beacon is DB and the diameter of the light input area of the photoreceptor is DP then the diameter of the folding mirror DM should be:

$$DM > \frac{1}{2}(DB + DP)$$

equation 8

7.4 Tristimulus Colorimeter [32]

A tristimulus colorimeter may be used to measure the colour of a light source. The device consists of three photodetectors, each with a filter that approximates one of the three colour functions \bar{x} , \bar{y} and \bar{z} . The three outputs are then arranged to give X, Y and Z values, or computed to give x, y chromaticity. Additionally, because the Y function is the same as $V(\lambda)$, the Y output may be calibrated to give a luminous value (e.g. lux). Colorimeters are sometimes combined with a luminance meter aperture, often with input optics.

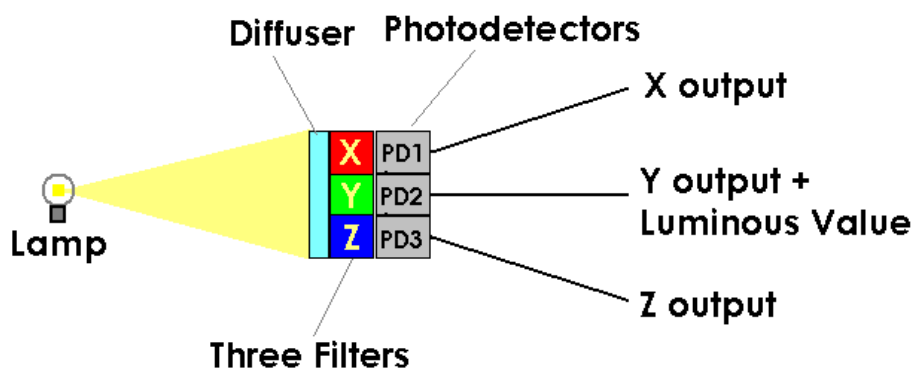

Figure 21 Schematic of a simple Tristimulus Colorimeter

Tristimulus colorimeters have the advantage that a relatively fast measurement can be made of colour. However, cheaper models may yield significant errors because the filters do not faithfully follow the colour functions. Such errors are more noticeable when measuring light

sources with a narrow spectral distribution. A relative spectral calibration of the colorimeter, showing the function of each filter, may help identify errors.

A method for carrying out a colour measurement using a tristimulus colorimeter is given in ANNEX IV.

7.5 Monochromator [14]

A monochromator is a device that can select narrow bands of light (near-monochromatic) from a given light input. It employs an entrance slit, some means of splitting the light into component wavelengths (e.g. a diffraction grating or prism) and an exit slit. The bandwidth of the output monochromatic light is dependant on the spacing of lines in the grating together with the slit width. The diffraction grating may be rotated to select different wavelengths of light.

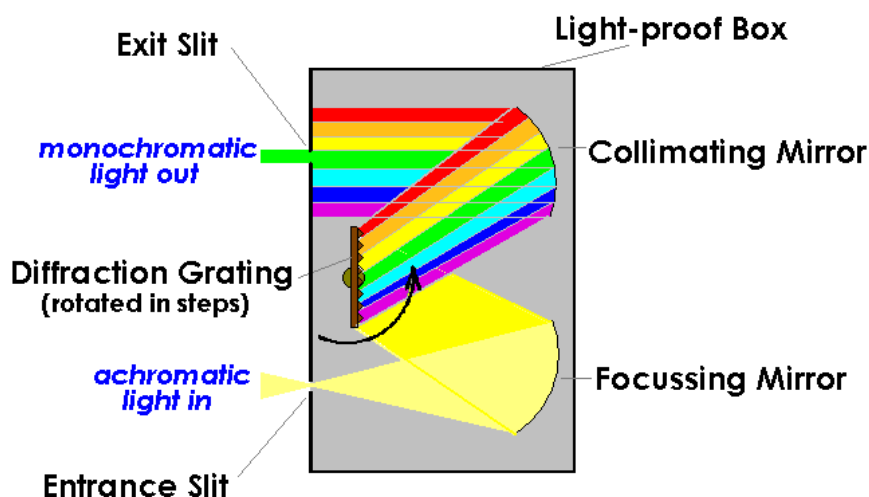

Figure 22 Schematic of Czerny-Turner Stepping Monochromator

7.6 Spectroscope, Spectrometer, Spectroradiometer

- A spectroscope is a device used to observe the spectrum;
- A spectrometer is a spectroscope equipped with the ability to measure wavelengths;
- A spectroradiometer is a device for determining the radiant-energy distribution in a spectrum.

7.6.1 Scanning or Stepping Spectroradiometer

A scanning spectroradiometer is a monochromator, such as the Czerny-Turner in Figure 22, with a radiometer head (typically a photodiode or photomultiplier) coupled to the output slit. The radiometric power may then be measured for each component wavelength or waveband on the light shone into the input slit.

Typically, the diffraction grating is turned in increments and a radiometric measurement taken at each incremented step. Such devices are quite slow and may not be suitable for flashing light sources. They are however, capable of great accuracy but can be prone to mechanical instability and need frequent calibration.

7.6.2 Array-based Spectroradiometer

An array-based spectroradiometer uses a monochromator that is fixed and where the output slit is replaced by an array of charge-coupled devices (CCDs) that act as individual radiometric receptors for each waveband. CCDs record the amount of charge, which is dependent on the exposure time to the light being measured. This exposure time is commonly known as integration time, which can be varied to accommodate varying levels of light input.

7.7 Calibrated Light Sources [30]

Calibrated sources, while not required when a calibrated photometer is used, are useful for making comparative measurements [21]. The comparative method of measurement is sometimes known as ‘measurement by substitution’, where the item under test is substituted for the calibrated light source and measured over the same measurement path. Sources calibrated at a national standards laboratory, and traceable to the national standard, are sometimes known as ‘standard lamps’, ‘standard reference lamps’ or ‘transfer standards’. Such lamps require carefully regulated power supplies and also require their voltage and current to be measured with low uncertainty. The equipment used to measure their voltage and current should also be traceable to national standards; otherwise the ‘transfer standard’ becomes meaningless.

Transfer standards may be calibrated for luminous intensity, colour temperature or spectral radiance or irradiance. A calibrated selective emitter, such as an LED source, may also be used as an alternative to spectral correction when the relative spectral responsivity of the photometer is not available.

Measurement by substitution is useful when the spectral transmittance of the measurement path is not linear; for instance, when measuring over a large distance, or when using adaptive optics such as a folding mirror or a collecting lens on the photometer. For scanning spectroradiometers, that can suffer considerable short-term calibration drift, it is recommended that a spectral irradiance standard reference lamp be used to calibrate the instrument before every measurement session.

8 GENERAL LABORATORY PROCEDURES

Testing facilities should establish and maintain a quality system appropriate to the type, range and volume of calibration and testing activities it undertakes. All procedures for conducting calibrations and photometric measurements should be documented as part of the quality system.

8.1 Written Procedures and Documentation

It is recommended that guidelines on laboratory equipment given in ISO 17025 be followed [20].

8.2 Test Equipment Identification

A list of all test equipment used in the measurement, including model numbers, serial numbers and calibration details, should be included in the test results and any documentation produced from those results.

8.3 Calibration and Traceability

All test equipment should be calibrated at an accredited test house and the calibration traceable to a national standard. Test equipment should be calibrated at regular intervals and, if calibrated in house, should be calibrated using equipment traceable to national

standards. When a replacement calibration certificate is issued, the calibration notes should be checked for any undue variations from the previous calibration. Large changes to calibrated values may affect the uncertainty budget of prior measurements.

All items of test equipment should be uniquely identified. Details of all test equipment should be logged in a register stating manufacturer, model number and serial number. The register should also show calibration due dates for each separate item of test equipment, to ensure that calibration is maintained at correct intervals. Calibration labels, identified with the calibration certificate serial number, equipment serial number and next due date of calibration, should be firmly fixed to the test equipment by the test house upon completion of calibration. Any obsolete calibration labels should be removed from the test equipment by the test house.

8.4 Identification of Test Items

Each item under test should be described and uniquely identified. If there is no manufacturer's label, or if the label contains insufficient information to enable the item to be identified uniquely, a label should be attached giving a unique identification for test purposes. The information given on the label should be included in the test results and any documentation produced from those results.

8.5 Items Under Test

The item to be tested or measured should be checked to ensure that it is in good operating condition. Its optical system should be outfitted with the appropriate light source, which may be supplied by the manufacturer or be a standard laboratory test lamp, and focused (if required) in accordance with the manufacturer's instructions or standard laboratory procedure.

Laboratory test lamps should be selected for close conformance to design dimensions, rated power consumption, and rated lumen output. Manufacturing tolerances between individual lamps of the same manufacturer's specification may be very large causing a correspondingly large variation in the intensity of a beacon. Parameters such as filament coil spacing and size also impact greatly on the intensity distribution, therefore close inspection and selection is recommended. A test procedure should be written to ensure conformance of laboratory test lamp properties within 3% of the manufacturer's specification [11].

When a lampchanger is included as part of the test item, lamps should be installed in all positions of the lampchanger where they might impact on the photometric output of the item under test. Lamps should be seasoned by running them for a few tens of hours prior to initial use [11]. Note that all light sources, particularly LEDs and discharge lamps, may require several hundred hours of operation (ageing) prior to being used for measurement purposes.

Marine aid-to-navigation light signals should be tested at rated voltage, rather than current or power. The voltage should be monitored, with sense leads attached as close as practical to the lamp inputs or controlling circuitry inputs, and kept constant throughout the measurement process. Current should also be monitored and recorded, to detect any changes in the input power during measurements and allow for correction of measured photometric output (see 8.11).

In the case of LED light sources with conditioning circuitry, both the input voltage and current to that circuitry should be monitored. Stand alone LED's are normally rated at a given current rather than voltage because dI/dV is very large at the operating point therefore, in the absence of conditioning circuitry, current should be controlled and monitored rather than voltage. LED aging should be taken into account when carrying out intensity measurements on new beacons and those that have been in service for several years.

8.6 Environmental Conditions

Ambient conditions for indoor measurements should be stabilized at $25(+5/-10)^{\circ}\text{C}$ and $60(\pm 10)\%$ relative humidity. In the case of outdoor measurements, the temperature and relative humidity should be noted at the time of the measurement. Any significant changes in ambient conditions during the course of the measurement should be recorded.

8.7 Power/Electrical Conditions

For tests involving equipment powered by a dc power supply, the output voltage and/or current should be maintained within $\pm 0.1\%$ or better, unless otherwise specified by the person requesting the measurement. When output voltage is controlled, the voltage should be monitored as close to the light source as possible. Ripple voltage should not exceed 0.4% of the dc output voltage.

For tests involving equipment powered by an external ac power supply, the output rms voltage or current should be maintained within $\pm 0.5\%$. The rms summation of the harmonic components, caused by departures from a true sinusoidal waveform, should not exceed 3% of the rms value of the fundamental frequency. Readjustment of the output voltage may be required during measurements if adequate stabilization is not achieved.

8.8 Equipment Warm-up

All test equipment requiring electrical power should be switched on and allowed to warm up in accordance with the manufacturers' operating instructions or calibration certificates before commencement of any tests or measurements. In the absence of such guidance, the measurement facility should evaluate the performance of test equipment to determine the required warm up period to prevent drift for each piece of equipment.

Items under test should be run at rated power for a sufficient period of time to ensure stability. The warm-up time selected for any type of light source should be documented in the laboratory procedures, and used consistently.

8.9 Stray and Ambient Light Control

Stray light control includes eliminating reflected light of the item under test, from walls, floors, and other surfaces, from reaching the photodetector. Ambient light control includes eliminating or reducing the amount of light from sources other than the item under test. The impact of ambient light may be determined by removing power to the item under test and recording the output of the photodetector. The impact of both elements may be determined by taking measurements with the item under test on, but with the direct light path occluded by a screen just larger than the light source aperture.

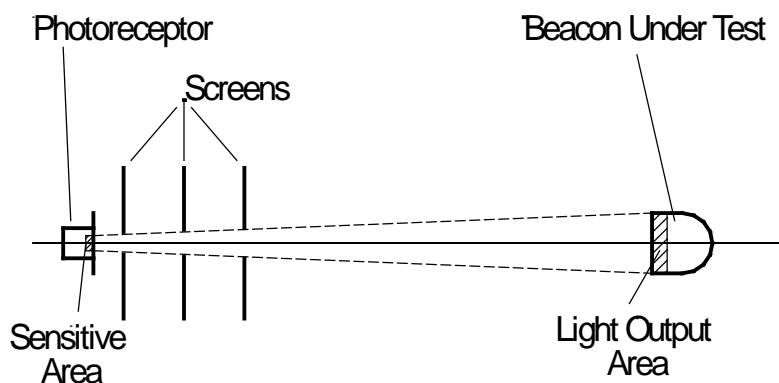

Figure 23 Stray light reduction by absorbing screens

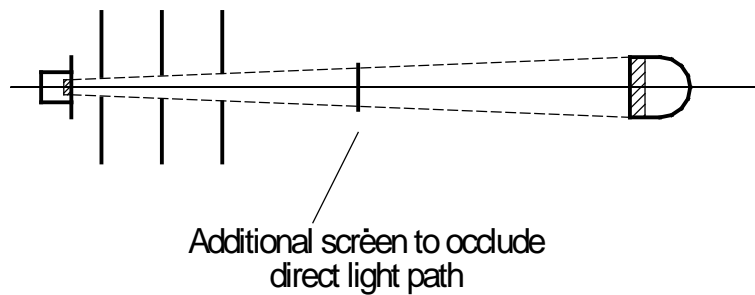

Figure 24 Arrangement to determine ambient and stray light

8.10 Source/Data Identification

The 'raw' or 'source' measurement data should be clearly identified and stored in accordance with [20]. The use of this data in any subsequent report or test sheet should be made fully auditable, so that the original measurement data can be referred to without ambiguity.

8.11 Power Monitoring of Item under Test

The power consumption of the item under test should be measured and recorded at the time of the photometric measurement. For electrical systems, power monitoring should be conducted throughout the measurement process. For other systems, such as gas or liquid fuel, monitoring of fuel consumption rate should be carried out, as a minimum, at the beginning and end of the measurement process or as an average over the time taken to carry out the measurement.

8.12 Recording System

All relevant measurement information should be recorded. The recording medium may be manually operated pen and paper, automatic chart plotter or electronic storage such as a computer. The recording system in use should have a response time fast enough to faithfully record all relevant data output from the measuring system.

8.13 Software

Details of all software used in any measurement process should be recorded. Custom software used in data acquisition, analysis, and/or presentation of results should be documented, and a printed copy maintained with other test procedure documentation. Algorithms used to manipulate data should be documented.

8.14 Errors, Uncertainty and Confidence

An expression of the result of a measurement is incomplete unless it includes a statement of the associated uncertainty. The results of all measurements should state the range, within which the measured value is estimated to lie, for a stated level of confidence. All type A and type B uncertainties associated with the measurement process should be evaluated in accordance with ISO/IEC Guide 98:1995, 'Guide to the Expression of Uncertainty in Measurement' (GUM)[9]. A suitable uncertainty budget should be produced for each measurement process undertaken.

Type A evaluation of uncertainty is made by statistical analysis of a series of observations. Type B evaluation of uncertainty is made by means other than the statistical analysis of the observations; for example, the uncertainty quoted on the calibration certificate of an item of test equipment.

8.14.1 Systematic Errors (Characterisation)

Any fixed errors within the measuring system should be evaluated and, where possible, corrected by the use of an appropriate correction factor. These errors and corrections should be recorded but not necessarily given with the measurement results. Appropriate uncertainty and confidence figures associated with error correction should be included in the uncertainty budget.

8.14.2 Combined Standard Uncertainty

The combined standard uncertainty is calculated by combining the individual uncertainties that comprise the uncertainty budget using the square root of the sum of the squares of the individual uncertainties.

8.14.3 Expanded Uncertainty

The expanded uncertainty is obtained by multiplying the combined standard uncertainty by a coverage factor, k . Unless otherwise determined, it may be assumed that the probability distribution of a measurement result and the combined standard uncertainty is approximately normal. The combined standard uncertainty is equivalent to the standard deviation of the Gaussian distribution. An appropriate coverage factor should be determined in order to provide a confidence level of 95%.

8.14.4 Sampling Guidelines

Sampling consists of taking a sufficient number of measurements for a given condition to minimize the impact of minor random fluctuations in the measurement process. A coverage factor between 2 and 3 should be achieved, consistent with the evaluation of uncertainty figures and confidence levels [9]. Sampling procedures should be documented as part of the standard laboratory procedures. Exceptions to standard sampling procedures should be discussed in any test results.

8.15 Notes/Comments

A copy of all information relevant to the measurement, including observations, modifications, statement of requirements and item under test manufacturer's instructions, should be retained with the recorded data.

8.16 Authorised Signatories

The person or persons carrying out the measurement should be authorised to do so by the facility or laboratory undertaking the work. A record of the person carrying out the measurement, along with the date when the signature was written and the place where the measurement was carried out, should be kept with the recorded test results and on any ensuing publication.

8.17 Retention of Data

Retention of data should be in accordance with local laboratory procedure.

9 PHOTOMETRY METHODS AND REQUIREMENTS

9.1 Standard Laboratory Photometry

The measurement of the luminous intensity of a light source in the laboratory is usually carried out by taking an illuminance reading, in lumens per metre squared (lux), of the light source at a measured distance, in metres. The luminous intensity in candelas may then be

calculated by multiplying the illuminance by the square of the distance, this is known as the Photometric Distance Law [5] (see 5.1). The transmissivity of the atmosphere over short distances in the laboratory may be taken as unity. The light source and photometric receptors are usually mounted on an optical bench or table to reduce the uncertainty of distance measurement. To ascertain the luminous intensity of the light source in more than one direction, the light source may be rotated about its light centre and several illuminance readings taken at different orientations. To ascertain the total luminous flux emitted by a light source, an integrating sphere may be used. Photometers, used for measuring illuminance, have a photopic spectral response that approximates the standard human observer, $V(\lambda)$ [6].

Provided the measuring distance is relatively large compared to the size of the light source (greater than fifteen times as a rule of thumb), this method is simple and accurate for unfocussed light sources. However, when measuring light beam projection apparatus, such as a light source and lens or mirror system, much greater measuring distances are required to ensure an error free result when using this method. At these greater distances several problems arise, such as the effects of atmospheric transmissivity and disturbance, and the difficulty in measuring much lower levels of illuminance. The projection apparatus may be rotated through different angles and illuminance readings taken to determine the shape of the projected beam. A goniometer is usually employed to facilitate the measurement of intensity against angle.

When measuring the output of bare light sources such as incandescent lamps, the quantity of total luminous flux in lumens is usually obtained by placing the light source in an integrating sphere which collects the whole luminous output from the lamp. Such spheres need to be several times larger than the light source being measured and require careful calibration but the output is useful measure of a lamp's performance. The total luminous flux is the figure usually quoted by lamp manufacturers.

Further guidance on basic photometry can be obtained from CIE publications [5], [8], [19] and [31].

9.2 Alignment

A datum point should be identified on the perimeter of the item under test such that it clearly defines a direction of radiation towards the horizon. This may be a manufacturer's mark or one put there by the testing laboratory. Items under test should be installed on the goniometer and aligned with the measurement system such that the datum point is in line with the measurement direction. Where possible, the height of the goniometer table should be adjustable so that both the horizontal and vertical axes of the optic may be aligned with the rotational axes of the goniometer. If this is not possible, due to the design constraints of the goniometer table, the errors in measurement distance caused by tilting the table should be corrected or included in the uncertainty budget. The centre of the photodetector aperture should lie along the line normal to the rotational axes of the goniometer. The alignment process and its associated uncertainty should be part of the documented laboratory procedure. Since the angle of incidence is always close to zero, there is no need to carry out cosine correction.

When a flat folding mirror is used, the distance from the item under test to the mirror should be as close as possible to the distance from the mirror to the photometer. The reflection angle of the light path should be minimised. The normal of the mirror surface should lie on the plane described by the optical axis of the item under test and the reference plane of the goniometer [19].

For all measurement procedures, the measurement distance and measurement angle should be known and reported.

9.3 Photometric System Response; $V(\lambda)$ and f_1'

The overall spectral response of the photometric system used should approximate closely the spectral luminous efficiency function $V(\lambda)$ for the CIE standard photometric observer in photopic vision (see 6.1). For broadband emitters, such as incandescent lamps, a single value measurement of the spectral response, the closeness of fit (f_1') [6] figure of the system, may be used to determine measurement uncertainty. For light sources with narrow or rapidly varying spectral distribution, such as LEDs or metal-halide lamps, the deviation of the response of the photometric system from $V(\lambda)$ for specific wavelengths may have to be accounted for by use of spectral correction (see 9.4).

9.4 Spectral Correction

Even photometric systems with low f_1' figures can exhibit significant errors at extremes of the visible spectrum. If the light source being measured has a spectral power distribution that is significantly different from the calibrating light source, especially if it has a narrow band of distribution (such as LED sources), spectral correction should be undertaken. An accepted method of correction is by use of a spectral correction factor (SCF) [6], as given by:

$$SCF = \frac{\int_{\lambda} S_A(\lambda) S_{rel}(\lambda) d\lambda \int_{\lambda} S_t(\lambda) V(\lambda) d\lambda}{\int_{\lambda} S_A(\lambda) V(\lambda) d\lambda \int_{\lambda} S_t(\lambda) S_{rel}(\lambda) d\lambda}$$

equation 9

where:

$S_t(\lambda)$ is the spectral power distribution of the test lamp;

$S_A(\lambda)$ is the spectral data of the CIE Illuminant A;

$S_{rel}(\lambda)$ is the relative spectral responsivity of the photometer.

Using this equation, the correction factor can be obtained for any light source of known spectral power distribution (see 4.18). If a calibrated light source is being used as a reference, its spectral power distribution $S_R(\lambda)$ may be substituted for $S_A(\lambda)$.

The correction factor will have an associated uncertainty derived from the spectral measurement process and the pertinent calibration details of equipment used in the measurement.

A second method of spectral correction is by use of a calibrated light source with the same spectral power distribution as that of the test lamp. Measurement of the calibrated light source will establish a scaling factor that may be used to correct the measured illuminance of the item under test.

9.5 Measurement of Angular Dependency of Luminous Intensity [18]

The measurement of angular dependency, sometimes called the angular distribution, of luminous intensity (see Definitions) is usually carried out by using a goniophotometer. A goniophotometer consists of a goniometer (tilt and turn) table, on which the item under test is mounted, and a distant photometer that measures the light emanating from the item. As the goniometer is moved or stepped through various angular positions, the photometer records the luminous intensity at each angle. There is an important relationship between the angular resolution of the goniometer and the measurement angle of the photometer (see 9.9).

In order to carry out angular measurements using the goniometer it is usually necessary to make the item under test exhibit a fixed light. For rotating beacons, this can be achieved by disabling the rotation mechanism and locking the mechanism in one position. If the item

under test emits more than one beam, each beam axis or surface should be identified with the datum clearly defined. Separate vertical and horizontal plots should be carried out for each beam axis.

If the light source within a rotating beacon is non-uniform and the measurement is to be carried out by rotating the whole beacon, including the light source, on the goniometer, additional output data for the bare light source, for example a lamp polar plot, should be obtained. If the measurement is to be carried out with the lamp in a fixed position and not rotated with the goniometer, measurements of all emitted beams should be carried out with the light source in two different positions, those that give maximum and minimum intensity.

For omnidirectional beacons with a flashing light source, the light source should be made to light continuously by following instructions in the manufacturer's handbook. If no instructions are available, advice from the manufacturer or supplier should be sought. It should be noted that the continuous intensity of a beacon exhibiting a fixed light may be different to the peak intensity of the same beacon when it exhibits a flashing light (see 11.4)

9.6 Minimum Requirements for Angular Resolution

The following are minimum requirements for the two main types of marine aids-to-navigation optical systems:

9.6.1 Omnidirectional lantern—(fan beams)

- horizontal profile, 360 degree plot, readings every 1.0 degrees or less;
- vertical profile to the 1% intensity points (or the lowest possible reading), readings every 0.1 degrees or less.

A minimum of three equidistant vertical profiles should be recorded, one of which should be taken at a position where the on-axis intensity is close to the 10th percentile value for the horizontal profile. Additional vertical profiles may be necessary to adequately investigate irregularities in the horizontal profile.

9.6.2 Directional and rotating beacons and precision projectors

- horizontal profile to 1% intensity points (or the lowest possible reading), readings every 0.1 degrees or less;
- vertical profile to 1% intensity points (or the lowest possible reading), readings every 0.1 degrees or less.

9.7 Measurement of Time Dependency of Luminous Intensity

In order to determine the effective intensity of a flashing omnidirectional aid-to-navigation light operating at a chosen character, the time-dependent luminous intensity profile should be measured. The absolute values of the instantaneous luminous intensity do not have to be measured, as long as the peak intensity during a flash is equal to the intensity measured when the item under test provides a fixed light. This requires that the time duration of a flash generated by a contact-closure (such as a tungsten-incandescent lamp that is switched on and off) be of sufficient length to ensure that full output of the light source is achieved. Examples of types of illuminant that may exhibit different values of instantaneous peak intensity and continuous intensity are:

- A tungsten filament lamp whose time to reach full incandescence is greater than the contact-closure time (CCT) of the device controlling the lamp supply; [2]
- An LED whose luminous intensity reduces with time when supplied with constant current, this being the result of an increase in junction temperature of the LED.

Care should therefore be taken to ensure that such devices either reach full incandescence during the measurement of the flash profile or that the relationship between instantaneous peak intensity and continuous intensity is known. The latter may be treated as an error to which a correction factor is applied with an associated correction uncertainty.

For rotating beacons, the instantaneous luminous intensity may be plotted against time by allowing the beacon to rotate under its own power and recording each beam as it passes the measuring instrument. With this method, the light source does not usually rotate. If the light source is non-uniform, measurements of all emitted beams will be carried out with the light source in two different positions, those that give maximum and minimum intensity.

9.8 Minimum Photometric Distance

Before commencing a measurement, the minimum photometric distance of the item under test should be estimated. This involves calculating the crossover distance for a projection apparatus such as a marine aid-to-navigation light. John W. T. Walsh described a method for determining crossover distance in his book on Photometry [8] as follows:

$$d = \frac{R^2}{4f} + \frac{R}{r} \left(f + \frac{R^2}{4f} \right)$$

equation 10

where:

- d = crossover distance
- f = focal length of optical system
- R = radius of optic aperture
- r = radius of light source

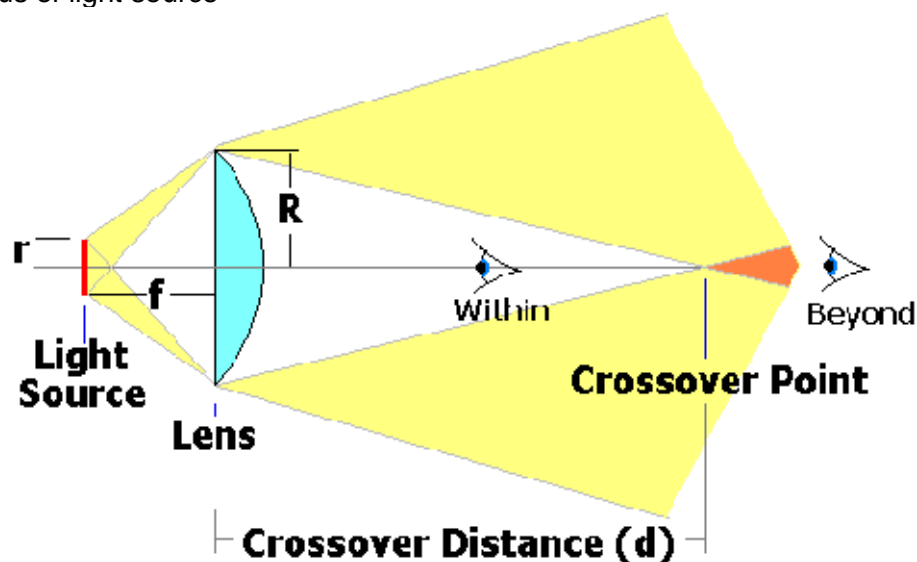

Figure 25 Crossover Distance

An approximation of crossover distance can be obtained by the formula:

$$d = 2 \frac{fR}{r}$$

equation 11

The approximation only holds good for an optical lens system with a collection angle of approximately 63°. If the collection angle is markedly different, the full formula, as prescribed by Walsh, should be used.

Equation 11 is good for circular optical apparatus with a spherical light source but when the optical system is larger in one dimension than another; for example, a rectangular lens with a cylindrical light source, the vertical and horizontal crossover distance will be different. In this case the formula can be expressed as follows:

$$d = 2 \frac{fH}{h}$$

equation 12

where:

d = crossover distance
 f = focal length of optical system
 H = height of optic aperture
 h = height of light source

or:

$$d = 2 \frac{fW}{w}$$

equation 13

where:

d = crossover distance
 f = focal length of optical system
 W = width of optic aperture
 w = width of light source

Both the crossover distances of height and width should be calculated and the greater of the two used. For an omnidirectional beacon, only the vertical crossover is relevant, therefore only equation 12 is relevant.

For a precision sector projector, the crossover distance may be expressed as follows [27]:

$$d = 2 \frac{R}{\alpha}$$

equation 14

where:

d = crossover distance
 R = radius of optic aperture
 α = requested angular resolution

The minimum photometric distance may be taken as twice the calculated crossover distance.

In cases where the sizes of optical components are unknown, the minimum photometric distance may be determined by measuring the intensity at several different distances from the beacon, always on the same radial coordinate, and assessing the distance beyond which the resultant measured intensity is consistent [28]. In practice this will be restricted to small sealed beacons, whose component parts are not measurable.

9.9 Measurement Aperture and Measurement Angle

The measurement aperture is the physical size of the photoreceptor active surface, i.e. that area receiving light being measured. It is sometimes quoted as an area or, if the aperture is circular, a radius or diameter.

The measurement angle is described by the aperture over the measurement distance and usually refers to a point source of measurement. The measurement angle is important when carrying out goniophotometry, where a graph of intensity against angle is being plotted. The measurement angle describes the integral angle over which each incremented measurement is carried out, and should therefore approximate the goniometer incremented angle.

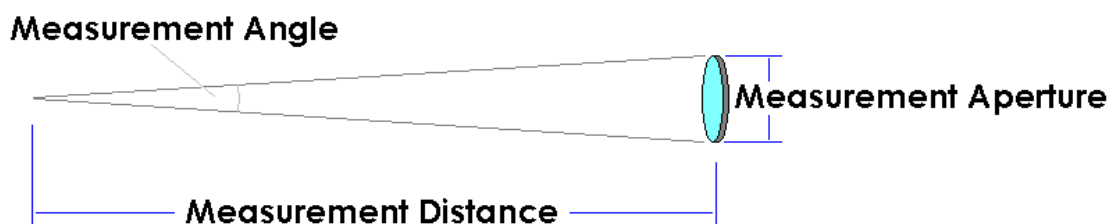

Figure 26 Measurement Angle

Providing $a \ll d$, the measurement angle may be calculated as follows:

$$\theta = 2 \times \arctan \frac{a}{2d} \approx \arctan \frac{a}{d} \approx \frac{a}{d} [\text{radians}]$$

equation 15

or providing $r \ll d$:

$$\theta = 2 \times \arctan \frac{r}{d} \approx \frac{2 \cdot r}{d} [\text{radians}]$$

equation 16

where:

- θ is the measurement angle
- a is the diameter of the measurement aperture
- r is the radius of the measurement aperture
- d is the measurement distance

9.10 Detailed Measurement Methods

In addition to these general measurement methods and requirements, two detailed methods, for the photometry of projection apparatus such as aid-to-navigation signal lights, have been reviewed and approved for inclusion in this document: Zero-Length Photometry (ANNEX II) and Outdoor Telephotometry (ANNEX III). Much of the equipment and measurement procedures are the same for all methods. Unique requirements for both methods are discussed in their respective sections.

These detailed methods have been reviewed and accepted as providing equivalent results, within stated uncertainties. Other methods of measurement are not excluded, but should meet the same criteria for traceability and evaluation of uncertainty described in this recommendation.

10 COLORIMETRY METHODS AND REQUIREMENTS

10.1 Standard Laboratory Colorimetry

The measurement of the colour of a light source in the laboratory is carried out by one of two methods; either by use of a tristimulus colorimeter (see 7.4), or a spectroradiometer (see 7.5 and 7.6). The results from either method should be reduced to x, y coordinates that enable a colour point to be plotted on a CIE 1931 chromaticity diagram (see 6.5) [24]. The transmissivity of the atmosphere over short distances in the laboratory may be taken as unity. The light source is usually mounted on an optical bench or table to reduce the uncertainty of distance measurement. To ascertain the colour of the light source in more than one direction, the light source may be rotated about its light centre and several measurements carried out at different orientations. To ensure that a light source fully and evenly illuminates the measurement aperture, a diffuser or integrating sphere may be used.

Provided the measuring distance is relatively large compared to the size of the light source (as a rule of thumb greater than fifteen times the greatest dimension of a light source), this method is simple and accurate for bare or unfocussed light sources where the measurement angle is unimportant. However, when measuring light beam projection apparatus, such as a light source and lens or mirror system, the measurement angle may be important and the rule of thumb no longer applies, especially when different coloured sectors are being measured. It is also important when considering the observed colour of a beacon comprising a cluster or array of LEDs that may exhibit different individual colours. If the measurement angle needs to be small, then either the measurement distance should be increased or the measurement aperture should be decreased. At greater measurement distances, the lower levels of illuminance at the measurement aperture may increase measurement uncertainty considerably due to instrument noise. A goniometer may be employed to facilitate the measurement of colour against angle.

When measuring the overall colour of a light, the measurement may be carried out by placing the beacon in an integrating sphere. However, if the angular dependence of colour is being measured (for example of a sector light), a minimum colorimetric distance should be employed. The crossover distance defined in 9.8 may be used for this purpose.

The junction temperature of an LED is proportional to its wavelength and the colour of an LED is therefore likely to change during its operation as the device current warms the junction. This means that there may be a significant difference between an LED exhibiting a rhythmic character with a low duty cycle and one exhibiting a high duty cycle character (e.g. occulting) or continuous light. It is recommended that an average of the colour over the duration of the flash be taken and that the LED be allowed to stabilise at its working temperature before a colour measurement is attempted.

Further guidance on basic colorimetry can be obtained from CIE publications [14], [24], [30], [33], [34].

10.2 Alignment

The datum point identified in 9.2 for photometric measurement should be the same, where possible, for colorimetry. The measurement distance and measurement angle (see 9.9) should be reported.

10.3 Measurement System Spectral Response

Tristimulus colorimeters have a spectral response that approximates the standard colorimetric observer (see 6.4) [24]. However, as with photometers, the three filters used to obtain the response inevitably introduce errors. Because the measurement process involves a combination of the responses of three filters, spectral mismatch correction is more difficult for tristimulus colorimeters than for photometers. Errors are more likely when measuring light sources with narrow spectral distribution (e.g. LEDs) and when that distribution is concentrated in a less sensitive part of the visible spectrum.

Spectroradiometers should ideally have a radiometrically flat response over the visible spectrum but this is never the case in practice. Calibration of the spectroradiometer with a lamp of known SPD (see 7.7) is usually carried out before and after each measurement session. Correction of the spectral response of the system is achieved by comparing the data obtained from the measurement of the standard lamp and the data from the standard lamp calibration sheet.

10.4 Illumination of the Measurement Aperture

When measuring colour it is important that the light to be measured fully and evenly illuminates the input aperture of the measuring instrument. This can be achieved by inserting a diffuser or integrating sphere between the light source and the measurement aperture. However, such devices can greatly attenuate the light input to the instrument.

10.5 Considerations of Rapid Intensity Fluctuation of the Light Source

As with photometers, the rapid fluctuation of light source radiant intensity can cause measurement errors. The temporal response of the measuring instrument should either be fast enough to follow the fluctuation or should be able to integrate the fluctuation accurately enough to give an average over the required measurement interval.

10.6 Minimum Measurement Distance

With aid-to-navigation beacons, the area of lit beacon seen by the observer should be considered when carrying out colour measurements. With bare or filtered incandescent lamps, the colour changes very little when viewed at different angles. However, this is not necessarily the case with clusters or arrays of LEDs, where a change of viewing angle will reveal a different group of light sources.

Often, the measurement distance will be limited by the sensitivity of the measuring instrument. Sometimes, optical gain can be employed to increase the light input to the measurement aperture. A “zero-length” measurement system, such as that described in ANNEX II for photometry, may also be used with good effect for colorimetry. However, the use of optical apparatus in the measurement path will introduce spectral distortion and such errors should be corrected. The use of a spectral standard lamp (e.g. measurement by substitution) can help eliminate such errors.

10.7 Detailed Measurement Methods

In addition to these general measurement methods and requirements, two detailed methods, for the colorimetry of projection apparatus such as aid-to-navigation signal lights, have been reviewed and approved for inclusion in this document: Tristimulus Colorimeter (ANNEX IV) and Spectroradiometry (ANNEX V). Measurement uncertainties for both methods are currently under review.

11 PRESENTATION OF RESULTS

A test report should be prepared containing all relevant results annotated to clearly identify the item under test, including the optical assembly and the light source (if separable). The testing procedures (standard laboratory photometry, zero-length photometry, or outdoor telephotometry) should be identified. Test conditions, including voltage settings, current consumption of the item under test and/or the light source (if independently powered) should be listed. Results of measurements of any laboratory test lamp used should be presented with results of the item under test.

Units of the measured results should be as follows:

time	seconds (s)
luminous intensity	candelas (cd)
angle	degrees (°)
luminous range	nautical miles (M)
chromaticity	values of x and y according to CIE 1931 diagram.

11.1 Luminous Intensity versus Angle

Results of the angular dependence of the luminous intensity should be graphically presented to clearly illustrate the performance of the lantern. Graphs should be linear and annotated to identify causes of irregularities in the intensity measurements, such as shadowing due to filament supports, effects of lens seams, etc.

11.1.1 Main Values of a Symmetric Intensity Distribution

An intensity distribution in a plane, which is symmetric about a reference axis (datum) can be characterised by three values:

- maximum intensity at reference axis: I_{\max}
- full width half maximum: FWHM
- full width tenth maximum: FWTM

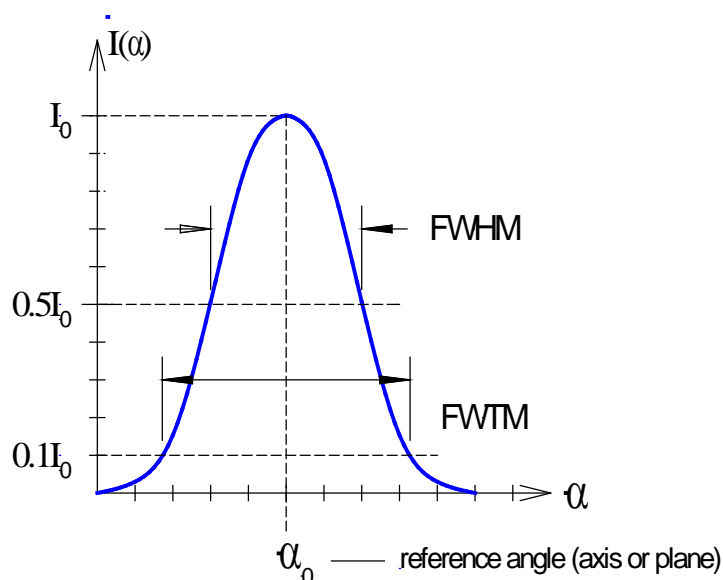

Figure 27 Symmetrical Intensity Distribution

In practice the distributions are not exactly symmetric and there may be minor maxima.

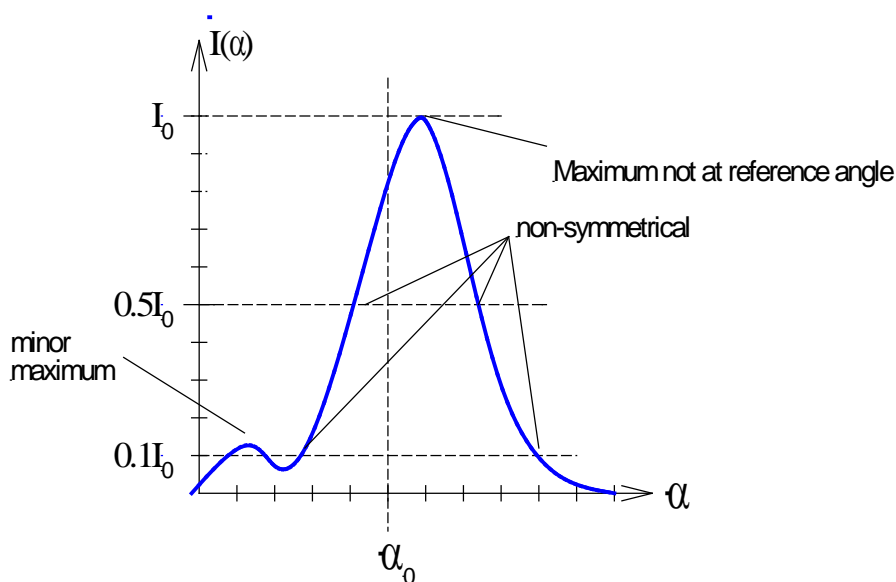

Figure 28 Asymmetrical Intensity Distribution

The I_{\max} figure reported should be the intensity at the reference axis. If an I_{\max} figure is reported that is not on the reference axis, the intensity value and the angle at which it was measured should be clearly stated.

The FWHM values reported should correspond to the angles either side of the reference axis where the intensity first falls to 50% of I_{\max} . An overall value of FWHM may be reported in addition but this should be clearly marked 'overall FWHM' or 'overall 50% divergence'.

The FWTM values reported should correspond to the angles either side of the reference axis where the intensity first falls to 10% of I_{max} . An overall value of FWTM may be reported in addition but this should be clearly marked 'overall FWTM' or 'overall 10% divergence'.

11.1.2 Reduced Values for Type Testing or Type Approval

For type approval testing, where a symmetrical distribution is specified or expected but measured results show an asymmetrical distribution, the values reported should be characterised by the intensity at reference axis I_0 , and the reduced overall angles:

$$FWHM_{red} = 2 \times \min\{\Delta_{H1}, \Delta_{H2}\}$$

$$FWTM_{red} = 2 \times \min\{\Delta_{T1}, \Delta_{T2}\}$$

This is so that the unexpected performance of a beacon is reflected in lower reported values for intensity and divergence angles.

Where:

$\min\{\Delta_{H1}, \Delta_{H2}\}$ is the smaller of the two values Δ_{H1} or Δ_{H2} .

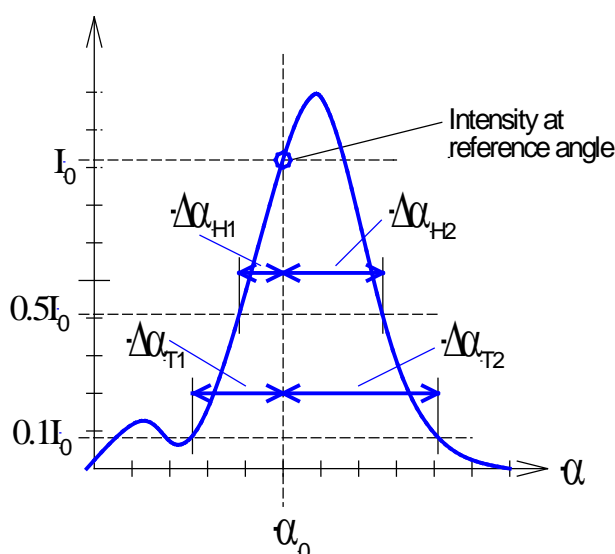

Figure 29 Asymmetrical Intensity Distribution showing Reduced Values

11.1.3 Main values for Omnidirectional Beacons (fan beams)

- Horizontal Profile

Graphs of the horizontal profiles should be plotted over $\pm 180^\circ$ from the vertical reference plane or datum. The following main values of the luminous intensity should be reported for the horizontal profile for an omnidirectional light signal, preferably annotated on the graph:

- maximum intensity: I_{max}
- minimum intensity: I_{min}
- mean intensity: I_{mean}
- 10th percentile intensity: $I_{10\%ile}$

The 10th percentile value, equalled or exceeded by 90% of the individual measurements of the luminous intensity in the horizontal plane, will be the value used to define the fixed (continuous) intensity of the beacon.

Note:

The luminous intensity of LED light sources under test may vary considerably with LED junction temperature and this can be a consequence of duty cycle of operation, for instance flash character. It is important therefore, to ensure that the peak intensity (I_0) in flashing mode is measured at the character specified and clearly labelled so as not to be confused with the fixed (continuous) intensity.

- Vertical Profiles

Measurements in a minimum of three vertical planes, preferably including and equidistant from the reference vertical plane or datum, should result in graphs of the vertical profiles plotted between the points where the intensity falls below 1% of maximum. Each graph should preferably be annotated with the main values I_{max} , FWHM and FWTM.

The average of all FWHM and FWTM results, above and below the horizontal reference plane, should then be reported (e.g. -3.1, +4.2 degrees).

For type approval testing, where the profile is expected to be symmetric about the datum, an asymmetric distribution shows deficiency in quality. Therefore, it is recommended to use the reduced overall values for FWHM and FWTM as described in 11.1.1.

11.1.4 Rotating Beacons (pencil beams)

Graphs of the vertical and horizontal profiles should be plotted between the points where the intensity falls below 5% of maximum. The main values I_{max} , FWHM and FWTM should be reported and preferably annotated on each graph. The horizontal angular intensity variation may be converted to a time-dependent profile at specific rotation rates for calculation of the effective intensity and flash duration. For rotating beacons with more than one emitted light beam, the results of all beams will be shown. The beam of least effective intensity shall be used to calculate the nominal range of the beacon.

If the light source within the beacon is non-uniform and the measurement was carried out by rotating the whole beacon, including the light source, on the goniometer table, additional output data for a bare lamp, e.g. a polar plot, should be presented. If the measurement was carried out with a non-uniform lamp in a fixed position and not rotated with the goniometer table, measurement results of all emitted beams will be presented for positions of the light source that give maximum and minimum intensity.

11.1.5 Directional Beacons

Graphs of the vertical and horizontal profiles should be plotted over the intended arc of utilisation of the beacon or to the horizontal angles where the intensity falls below 1% of maximum, whichever is the greater. Where applicable, the intended arc of utilisation should also be shown on the graph. The main values of I_{max} , FWHM and FWTM should be reported for both horizontal and vertical graphs, and preferably annotated on each graph. The 50% points will be used to define the vertical and horizontal divergences of the beam and should be given as minus and plus angles relative to the vertical reference plane. The 10% points should be shown on the graph but need not be quoted.

11.2 Luminous Intensity versus Time

For aid-to-navigation light signals that are flashed by eclipsing or switching the light source, the instantaneous luminous intensity profile versus time (flash profile) should be plotted with the luminous intensity as the dependent variable (ordinate) and time as the independent variable (abscissa). The plot should be linear and include the entire cycle of the flash

character, illustrating both the on and off periods. Secondary plots may be used to illustrate any short-duration fluctuations of the instantaneous luminous intensity.

For rotating beacons where the instantaneous luminous intensity is plotted against time by allowing the beacon to rotate under its own power, plots should be linear and show the luminous intensity profile against time for one complete revolution of the beacon. Secondary plots should also be used to illustrate individual emitted beams in greater detail. If the light source spatial distribution is non-uniform, measurement results of all emitted beams will be presented for positions of the light source that give maximum and minimum intensity. The periods between the times where the intensity falls or rises through 50% of peak intensity (10) shall be used to determine the rhythmic character of the light.

11.3 Flash Duration

The duration of the measured flash profile should be taken from the point in time when the intensity first exceeds 50% of the peak intensity value to the point in time when the intensity finally falls below 50% of the peak intensity value. The end of a flash should be considered as when the intensity falls below 5% of the peak intensity value for more than 100ms.

11.4 Effective Intensity

The effective intensity of a marine aid-to-navigation light shall be presented in the final results having been calculated using the method outlined in IALA Recommendation E-200-4 on Marine Signal Lights – Part 4 - Determination and Calculation of Effective Intensity. In the case of an omnidirectional beacon, the 10th percentile value of the horizontal plot should be used to scale the calculated effective intensity. It should be noted that a function to calculate a percentile value is available in many computer spreadsheet packages.

Note that some light sources have different intensities for continuous and flashed modes (e.g. LED's). Therefore, when the measurement of luminous intensity against angle is carried out with a continuous light source, the intensity measured for a given angle will be different than when the light source is flashing. In this case, intensity against time may be measured in both modes, ensuring the light source reaches stability in each mode, at the same angular reference (e.g. datum). The ratio of continuous intensity to flashing (peak or effective) intensity may be calculated and used to scale the 10th percentile figure. The rhythmic character used during the measurement of intensity against time should be reported with the effective intensity value.

11.5 Spectral Correction

Where the photometric result has been corrected by applying a spectral correction factor, the value of the factor, and how it was applied, should be clearly stated.

11.6 Service Conditions Allowance

Where applicable, a service conditions allowance may be applied to the measured intensity. This allowance accounts for the reduction in intensity through equipment degradation over the lifetime and service period of the equipment when it enters service. The details of such an allowance, and how it was applied, should be clearly reported.

11.7 Light Colour

The measured colour of the light should be reported in x, y coordinates according to the CIE 1931 chromaticity chart (see 6.5). Compliance with the appropriate IALA colour region should also be reported with reference to IALA Recommendation E-200-1 on Marine Signal Lights – Part 1 - Colours. At least three colour measurements should be taken at different points within the arc of utilisation.

If the equipment comprises more than one light source, an LED array for example, there are likely to be variations from one light source to the next. Furthermore, the colour of some types of LEDs, white phosphor-conversion types in particular, varies with angle of view. It is important for such devices that colour is measured at as many angles as possible within the zone of utilisation. As mentioned in 10.1, the device being measured should be allowed to reach a stable temperature before measurements begin and an average of the colour during the flash duration should be reported.

If all points lie within the recommended boundary, results may be shown as a scatter plot on a chromaticity chart. However, if there are deviations in colour from the recommended regions, a Cartesian plot of x, y chromaticity against angle is preferable because the angles at which deviations occur can be seen.

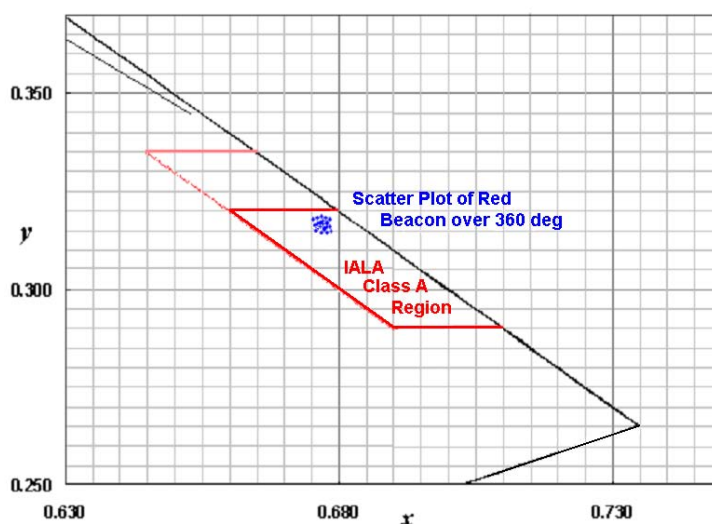

Figure 30 Scatter plot of red LED beacon over 360°

11.8 Sector Lights

If the colour of the light emitted by the equipment being tested varies with angle, for example a sector light with white, red and green sectors, the colour should be tested in at least three points within each coloured sector. The results of all measurements should be reported.

If the angle or sector of uncertainty (sometimes called the angle of indecision) at the boundary between two different coloured sectors needs to be defined, colour measurements can be taken at angular intervals across the boundary. The angle of uncertainty is defined as the angle distance from the point the colour departs from the IALA region of the first sector colour to the point the colour enters the IALA region of the second colour. The sector boundary, between the two colours, should be taken as the centre of the angle of uncertainty. The quoted sector arc should be taken between the sector boundaries and the quoted uncertainty given as half the total angle of indecision at each boundary:

e.g. Measured Red Sector Arc -132.5° to $-128.2^{\circ} = 4.3^{\circ} \pm 0.4^{\circ}$.

Where the angle of indecision is different for either boundary then these should be reported separately with the most positive angle first:

e.g. Measured Red Sector Arc -132.5° to $-128.2^{\circ} = 4.3^{\circ} +0.4^{\circ}/-0.3^{\circ}$.

It is important when measuring colour by angle to ensure that the angular increments are similar to the measurement angle of the instrument (9.9); otherwise sharp transitions in colour will be reported incorrectly (see IALA Guideline 1041 on Sector Lights). Figure 31 shows a Cartesian plot of chromaticity x, y coordinates against horizontal angle for a white

omnidirectional beacon with a red sector. The vertical yellow line shows where the colour of the light leaves the red IALA Class A region and the vertical blue line shows where it enters the white IALA Class A region. The angle of uncertainty covers 0.8° from -56.6° to -55.8°.

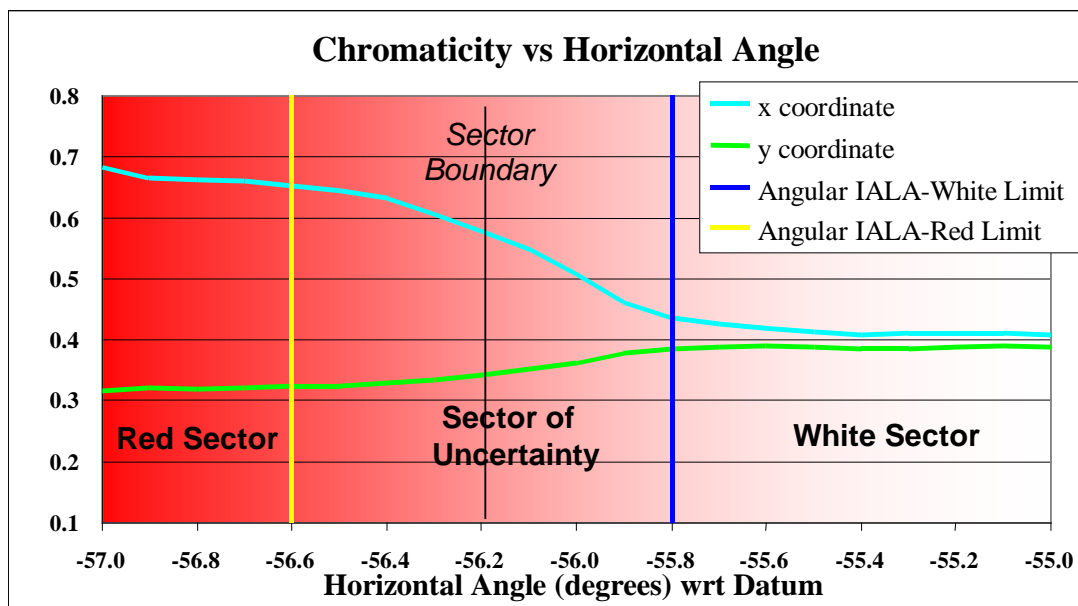

Figure 31 Plot of chromaticity across the boundary between red and white sectors

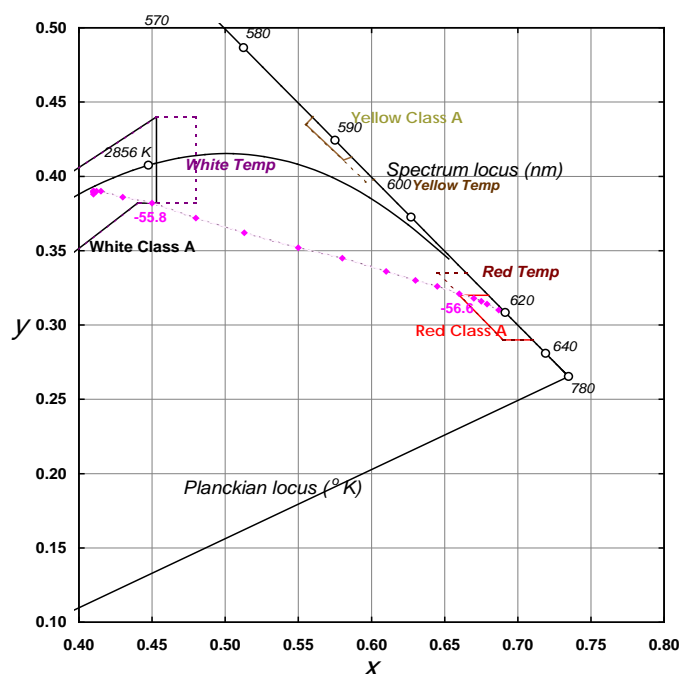

Figure 32 As Figure 31 but plotted on a partial CIE 1931 Chromaticity Diagram

The sector information and angle or sector of uncertainty may also be annotated on a plot of intensity against horizontal angle.

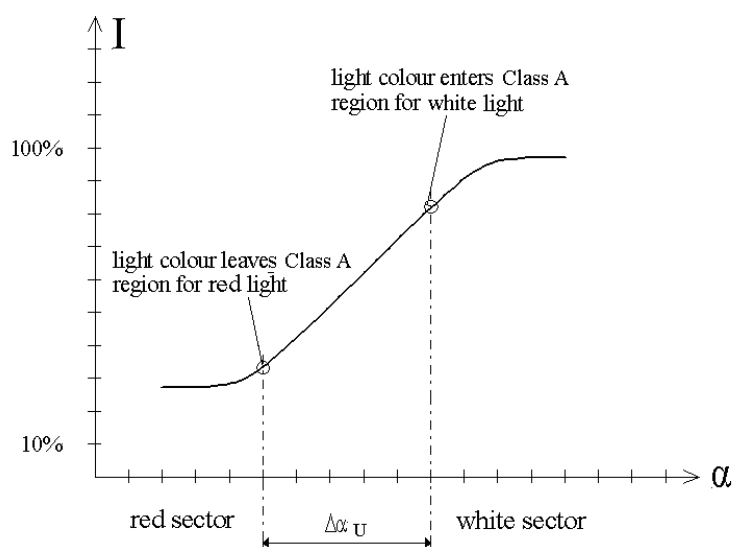

Figure 33 Method of Plotting Sector of Uncertainty on Intensity Graph

When carrying out measurements of sector lights it is important to bear in mind the accuracy of alignment of the measurement datum point. If the resolution of the angular measurement is 0.1 degrees, it is necessary for the datum point to be aligned with the measurement instrument to better than half that resolution angle. The angular uncertainty of this datum alignment should be quoted along with the measurement results.

It may be necessary for the horizontal angular information given in the results, i.e. that reported from the goniometer, to be replaced with the bearing from seaward of the intended location of the light. In this case, care should be taken to align the goniometer datum with the cardinal points of the compass and, where possible, to show bearings of landmarks intended for alignment.

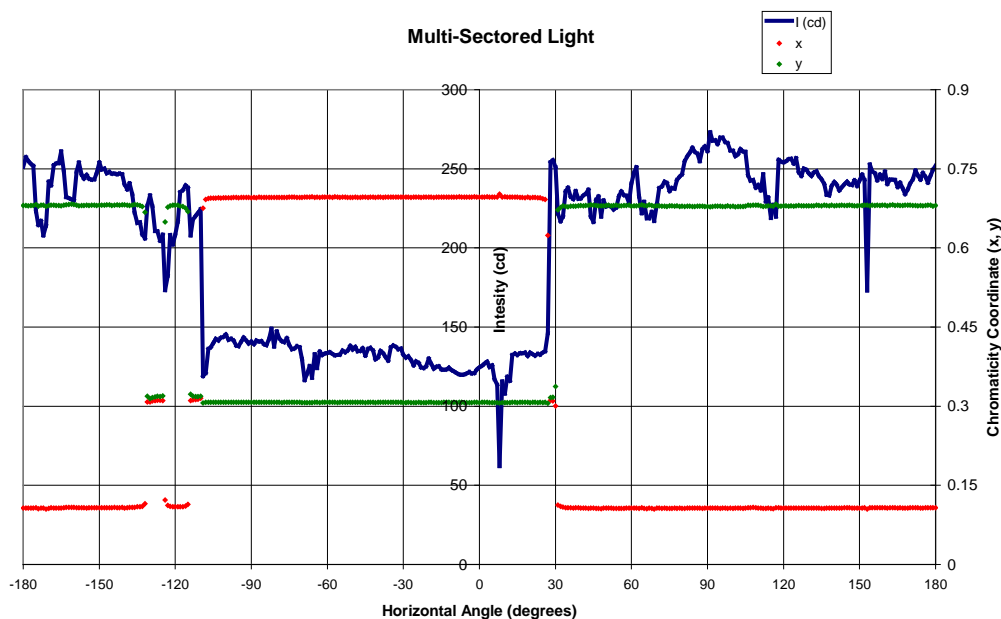

Figure 34 360 degree Plot of Sector Light showing Intensity and Chromaticity at 1° Intervals

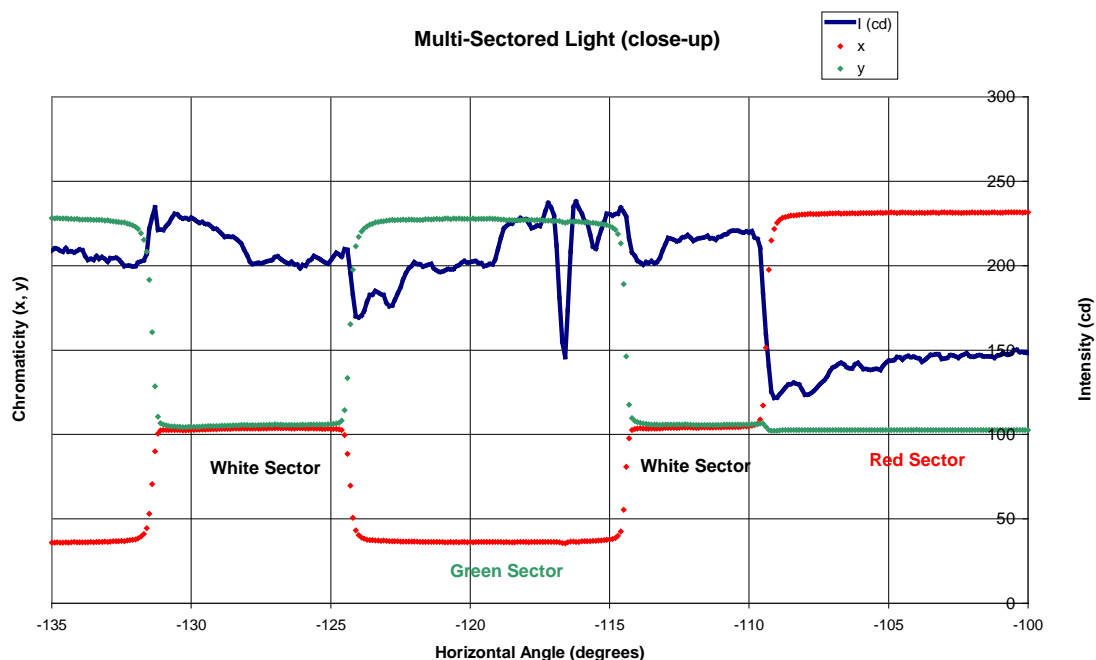

Figure 35 Partial Plot of Sector Light shown in Figure 34 Plotted at 0.1° Intervals

11.9 Spectral Power Distribution

The graph of SPD of a spectroradiometric measurement may be presented. Units of wavelength of the visible spectrum should be plotted on the independent variable (abscissa) and power (either relative or in Watts) should be plotted as the dependent variable (ordinate).

11.10 Nominal Range

The nominal range of the lowest resultant effective intensity of all flashes within the rhythmic character or lowest resultant effective intensity of all panels within a rotating optical system should be calculated according to IALA Recommendation E-200-2 on Marine Signal Lights – Part 2 - Calculation, Definition and Notation of Luminous Range and reported.

11.11 Uncertainty & Confidence

The results of all measurements should be presented with a statement of uncertainty and confidence level as outlined in 8.14.2 (also see ANNEX VI).

12 REFERENCES

- [1] International Association of Marine Aids to Navigation and Lighthouse Authorities (IALA), "Recommendations for the Colours of Light Signals on Aids to Navigation," December 1977.
- [2] IALA, "Recommendations on the Determination of the Luminous Intensity of a Marine Aid-to-Navigation Light," December 1977.
- [3] Schmidt-Clausen, H.J., "Über das Wahrnehmen verschiedenartiger Lichtimpulse bei veränderlichen Umfeldleuchtdichten" (Concerning the perception of various light flashes with varying surrounding luminances, Darmstadt Dissertation D17, Darmstadt University of Technology, 1968.
- [4] Graham, C.H., ed. "Vision and Visual Perception", John Wiley & Sons, Inc., New York, 1965.
- [5] International Commission on Illumination (CIE), Publication No. 18.2, "The Basis of Physical Photometry," 1983.
- [6] CIE Publication No. 69, "Methods of Characterising Illuminance Meters and Luminance Meters," 1987.
- [7] National Institute of Standards and Technology (NIST), Special Publication 250-37, "Photometric Calibrations", U.S. Department of Commerce, July 1997.
- [8] John W. T. Walsh, "Photometry," Dover Publications, 1965.
- [9] ISO/IEC Guide 98:1995, "Guide to the Expression of Uncertainty in Measurement", 1995.
- [10] CIE Publication No. 43, "Photometry of Floodlights" (Appendix C.2), 1979.
- [11] Illuminating Engineering Society (IES), Publication LM-54-1991, "IES Guide to Lamp Seasoning", 1991.
- [12] J. Johnson, "Zero-Length Searchlight Photometry System," Illuminating Engineering, Vol 57, No. 3, March 1962, p. 187.
- [13] IES, Publication LM-11-84, "IES Guide for Photometric Testing of Searchlights", July 1984.
- [14] CIE Publication No. 63, "The Spectroradiometric Measurement of Light Sources", 1984.
- [15] IALA Recommendation E-110 "on the Rhythmic Characters of Lights on Aids-to-Navigation", May 1998.
- [16] CIE Publication No. 86, "CIE 1988 2° Spectral Luminous Efficiency Function for Photopic Vision", 1990.
- [17] CIE Publication No. 127, "Measurement of LEDs" (Technical Report), 1997.
- [18] CIE Publication No. 70, "The Measurement of Absolute Luminous Intensity Distributions", 1987.
- [19] CIE Publication No. 121, "The Photometry and Goniophotometry of Luminaires", 1996.
- [20] ISO/IEC 17025, "General Requirements for the Competence of Testing and Calibration Laboratories", 1999.
- [21] CIE Standard 149-2002 "Use of Tungsten Filament Lamps as Secondary Standard Sources".

- [22] “Modified Allard Method for Effective Intensity of Flashing Lights” Yoshi Ohno and Dennis Couzin, CIE Symposium 2002.
- [23] Aerospace Recommended Practice, SAE ARP 5029 “Measurement Procedures for Strobe Anti-collision Lights”.
- [24] CIE Publication No. 15, “Colorimetry 3rd Edition”, 2004.
- [25] CIE Publication No. 84, “Measurement of Luminous Flux,” 1989.
- [26] CIE Publication No. 102, “Recommended file format for electronic transfer of luminaire photometric data”, 1993.
- [27] German Federal Waterways, “Minimum Photometric Distance”, 2006-01-31.
- [28] German Federal Waterways, “Determination of Photometric Distance”, 2006-01-31.
- [29] CIE S 014-1/E:2006, “CIE Standard Colorimetric Observers”
- [30] CIE S 014-2/E:2006, “CIE Standard Illuminants for Colorimetry”
- [31] CIE S 010/E:2004, “Photometry - The CIE System of Physical Photometry”
- [32] CIE Publication No. 179, “Methods for Characterizing Tristimulus Colorimeters for Measuring the Colour of Light”, 2007.
- [33] CIE Publication No. 53, “Methods of characterizing the performance of radiometers and photometers”, 1982
- [34] CIE Publication No. 10527(E), “Colorimetric observers”, 1991 (S002, 1986)
- [35] CIE Publication No. 17.4, “International Lighting Vocabulary”, 1987

ANNEX II DETAILED MEASUREMENT METHOD

Zero-Length Photometry

1 INTRODUCTION

Zero-Length Photometry is a methodology for approximating far-field conditions in a short distance. The principal technique of Zero-Length Photometry is the use of a paraboloidal mirror to optically place the detector at an infinite distance from the source and thus out of the near field. An incoming plane wave, incident upon a concave paraboloidal mirror is converted to a converging spherical wave. The resulting image is measured by a detector at the focal point of the mirror [12]. The Illuminating Engineering Society (IES) has presented this as an alternative method for photometric measurement of searchlights [13]. Figure 36 illustrates a Zero-Length Photometry system.

The mirror should be able to focus collimated rays from all sections of the mirror face to a spot no greater than the aperture of the photometer, while excluding off-axis rays. The diameter of the mirror should be greater than the largest dimension of the optical components of the item under test. A front-surfaced mirror is recommended to minimize losses. As with a folding mirror, the relative spectral reflectivity of the mirror should be measured and used in the calculation of the spectral mismatch correction factor.

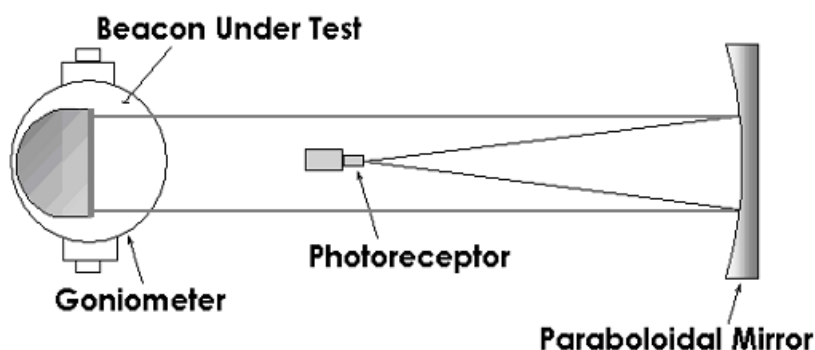

Figure 36 Zero-Length Photometry System.

The angular resolution depends on the focal length f and the size of the measurement aperture of the photometer head (see Figure 37).

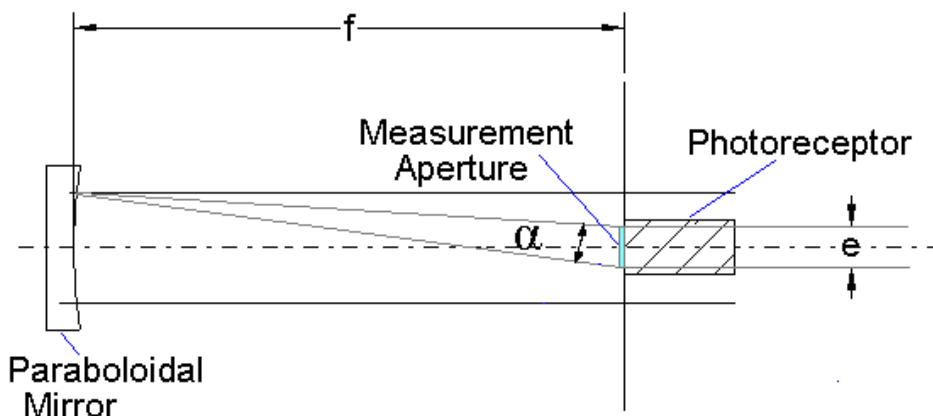

Figure 37 Zero-Length Geometry showing Angular Resolution

As an approximation the angular resolution can be expressed as follows:

$$\tan \alpha \approx \alpha \approx \frac{e}{f}$$

equation 17

2 OFF-AXIS ZERO-LENGTH PHOTOMETRY

The photoreceptor may be removed from the direct path of the light signal from the item under test by use of an off-axis paraboloidal mirror. This is especially important when measuring smaller optics, where the amount of obscuration may be a substantial proportion of the light signal. Tilting a centred system will achieve the same result, albeit with an increase in measurement uncertainty.

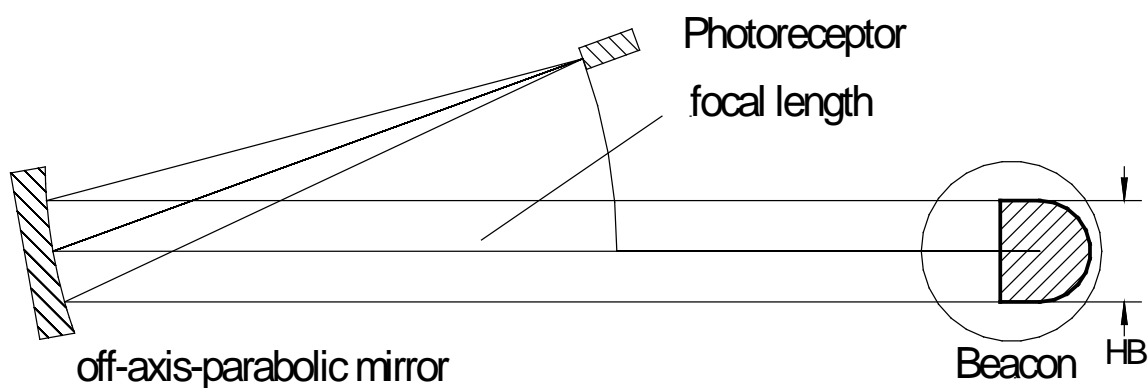

Figure 38 Off-Axis Zero-Length Geometry

3 CALIBRATING OR CHARACTERISING THE ZERO-LENGTH SYSTEM

Theoretically, all of the on-axis, collimated rays striking the paraboloidal mirror will be gathered at the focal point of the mirror. In actuality, there will be losses due to the overall spectral reflectivity of the mirror, non-uniformity of the mirror's reflective coating, and aberrations in the curvature of the mirror. The following method may be used to determine the losses through the zero-length setup. Measure the illuminance from a stable light source

at various distances from the photometer. Placing the source in a light box with a variable aperture will allow for generation of a very small source, so that the illuminance may be found to follow the photometric distance law within the limits of the measurement path. Precise alignment of the light box with the detector is required. The lamp current should be monitored and controlled. Make a series of measurements at distances beyond the minimum distance required for the photometric distance law to apply. Determine the intensity of the source and variance from the series of measurements. Move the light box to the goniometer and align with the mirror and the photometer. Monitor and control the lamp current as the illuminance (E_{meas}) is measured through the zero-length system. Using the intensity determined from the direct measurements (I_{direct}), calculate the 'corrected' length of the light path,

$$r_{corr} = \sqrt{\frac{I_{direct}}{E_{meas}}}$$

equation 18

where:

I_{direct} is in candelas

E is in lux

R_{corr} is in metres

The corrected light path length of the zero-length setup, r_{corr} , is then used to calculate the luminous intensity of the item(s) under test. Determination of the corrected light path length of the zero-length setup should be carried out whenever new data are to be recorded. Changes to the corrected length that cannot be accounted for in the uncertainty budget should be examined to determine if they are caused by some systematic error or equipment malfunction.

The variance recorded during the series of direct measurements of the light box includes the effects of a significant proportion of the elements that comprise the total uncertainty budget of the zero-length photometry setup. The variance may be used as the unexpanded uncertainty for those elements.

ANNEX III DETAILED MEASUREMENT METHOD

Outdoor Telephotometry

1 INTRODUCTION

Because some aid to navigation lights are projection systems, with minimum photometric distances in excess of 100 metres, all or part of the light range path may be situated outdoors. IALA Recommendations on the Determination of the Luminous Intensity of a Marine Aid-to-Navigation Light, 1977 [2], provides an overall recommendation for this type of measurement. Advantages are that a large building is not required and stray light bouncing off walls will not distort the measurement result. A further advantage is that this method allows for photometric measurements of lighthouses 'in situ'. Disadvantages of outdoor telephotometry are that ambient light levels, such as daylight, may be high and/or variable and that the state of the weather may affect the light path. The timing of the measurement may therefore be important, and testing may be limited to periods of fine weather or at night.

A further problem with long distance photometric measurements is that the photometer may not be sensitive enough to measure illuminance from a light source several hundred metres away. One solution to this is to use a sensitive photometer receptor (e.g. photomultiplier); another is to use optical magnification (e.g. telephoto lens or telescope) in front of the receptor. At extreme distance both options may be required.

Outdoor measurements may be divided into two types:

- Those carried out on an outdoor light range, where the item under test is mounted on a goniometer table and its intensity is measured against angular displacement; and
- Those of a lighthouse "in situ" where no goniometer is used, the character of the light is measured against time and shallow prisms are used to obtain a plot of the vertical beam profile

Just as for standard laboratory photometry, the path length used in outdoor telephotometry should be greater than the crossover distance of the item under test. A flat folding mirror may be used to double the path length of the light range. The photometer should be shielded from stray light emitted by the item under test when folding the light path.

2 ADDITIONAL EQUIPMENT REQUIRED FOR OUTDOOR TELEPHOTOMETRY

2.1 Telephotometer

The low values of illuminance that may be incurred when using an outdoor light range may result in the need to couple the photometer to a collecting telescope. The telescope should be capable of collecting light from the item under test and any reference source that might be used. It should also incorporate an iris so that the acceptance angle may be adjusted to exclude unwanted background light. The use of a telescope, or any such device in the optical measurement path, may alter the spectral correction factor, SCF.

2.2 Reference Light

To overcome uncertainties caused by varying atmospheric transmissivity over a longer measurement path, a reference light should be used. This is a light source of known

intensity, preferably one calibrated to national standards, with a controlled supply voltage and current.

In practice two measurements are made, one of the item under test and one of the reference light, which is placed in the same (or equivalent) physical position as the item under test. The two readings are then compared. This method does not rely on accurate measurements of distance nor does it require the photometer to be calibrated in absolute units. However, the photometer output should be directly proportional to the illuminance input. Any non-linearity should be accounted for in the uncertainty budget. The measurement path from the reference light to the receptor should, as far as possible, be the same as that from the item under test to the receptor.

3 CALIBRATION PROCEDURES

The use of a reference light as the comparator eliminates the need for absolute calibration of the light measurement system. However, calibration is required of the reference light itself, and the test equipment. The uncertainty in measurements due to the geometric relationships between the reference light, the item under test, and the photometer should also be evaluated and quantified.

4 ATMOSPHERIC CONDITIONS AND AMBIENT LIGHT

One of the greatest uncertainties in outdoor photometry is that caused by changing atmospheric conditions during measurements. Those contributing most to the uncertainty figure are changing visibility and scintillation.

A sizable error may result when visibility varies between the time of measurement of the item under test and the time of measurement of the reference light. If visibility is varying considerably, due to fog or rain, measurements should not be undertaken.

Variation of received light due to scintillation can increase the uncertainty of the resulting intensity figure in the same way as noise. This variation can be reduced by increasing the response time of the photometer or by using some averaging of the photometer output. However, care should be exercised when measuring flashing lights. Increasing the response time of the photometer may cause distortion of the measured flash profile. The response time used should be less than one tenth of the expected duration between the 50% intensity points of the flash. Several measurements should be made and an average of each flash profile can then be calculated.

Variation in ambient light, for instance when the measurement is being undertaken in daylight, can produce an error similar to a zeroing error. Care should be taken to ensure that readings taken from the photometer under ambient light conditions, i.e. with the item under test and reference light switched off, do not vary significantly.

5 RECORDING ENVIRONMENTAL CONDITIONS

A record should be made at the time of the measurement of the following environmental conditions:

- general weather;
- visibility;
- temperature; and
- relative humidity.

These data should be saved with the light range measurement data for the item under test. Visibility meters placed in the optical measurement path can be useful indicators during the hours of darkness.

6 ALIGNING THE TELEPHOTOMETER

Using a viewing sight, or similar apparatus, look into the optical path of the telescope and adjust the telescope alignment and focus until the item under test can be seen clearly in the centre of the eyepiece. The output aperture should then be adjusted so that only the item under test is visible.

The item under test should then be lit and allowed to come to full brightness. When viewed once more through the eyepiece care should be taken to avoid excessive glare to the eye. A filter may be inserted at the eyepiece to facilitate comfortable viewing. The goniometer table should then be turned through the desired angles of measurement to ensure that there is no obscuration of the light emitting surfaces by components in the optical path. When the image is satisfactory in all positions, the optical path output from the telescope should be directed to the photometer receptor.

7 MEASUREMENT PROCEDURES FOR OUTDOOR TELEPHOTOMETRY

Ensure the photometer is switched on and warmed up. The received light from the item under test falling upon the receptor should be measurable on the photometer readout. The gain of the photometer may need adjusting until a satisfactory reading is obtained. To ensure that the reading obtained is caused by received light, the light path can be interrupted and the effect on the reading observed.

The item under test should then be extinguished and the photometer reading observed. If the reading is not zero, due to ambient light, a zero offset may be used to reduce the photometer readout in ambient light conditions. Care should be taken however, when ambient conditions are variable, not to allow the reading to go below zero unless the recording system is suitable.

Complete measurements of the angular and time dependency of the luminous intensity of the item under test, as outlined in 9.7.

Following measurement of the item under test, mount the reference light on the goniometer table, and ensure that it is in the same position relative to the photometer as was the item under test. Allow the output of the reference light to stabilise, in compliance with the reference lamp calibration data. Take at least two measurements of the luminous intensity of the reference light as soon after the measurement of the item under test as is possible.

The reference light should then be powered down (or baffled, depending on the calibration conditions) and further photometer readings of the ambient light (or ambient plus stray light) recorded. The resultant average value of the reference light minus ambient light (or ambient plus stray light) and associated uncertainties should be calculated and recorded.

A minimum of three complete measurements should be carried to obtain average and uncertainty values.

8 ADDITIONAL EQUIPMENT FOR 'IN SITU' MEASUREMENT

8.1 Prisms and Prism Frame

For in situ measurements of large optical systems, a lighthouse lantern for example, it may not be feasible to mount the item under test on a goniometer table; nor may it be feasible to tilt the item. In these cases, the vertical beam profile may be measured by placing prismatic sheets on the focal plane of the item under test, to 'tilt' the beam by refraction. Two sets of such prisms, each providing 0.5° and 1.5° deviation, enable measurements to be taken over $\pm 2^\circ$ in 0.5° steps; a total of nine points on the vertical beam plot. A further step at $\pm 3^\circ$ is possible by the provision of a second set of 1.5° prisms; for a total of 11 points. The relative spectral transmissivity of the prisms, singly and in combination, should be determined and recorded (see Figure 39).

8.2 Reference Projector

For long-range measurements of high intensity beacons, a calibrated, high-intensity reference projector should be used as the reference light. The reference projector should be of comparable intensity, within two orders of magnitude, to the item under test.

Recommendation E-200-3 – Marine Signal Lights, Part 3 – Measurement
December 2008

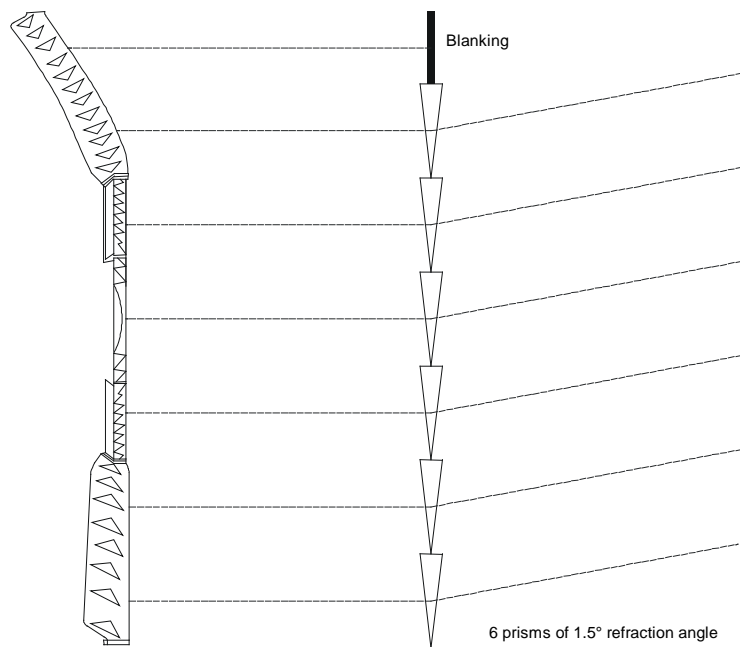
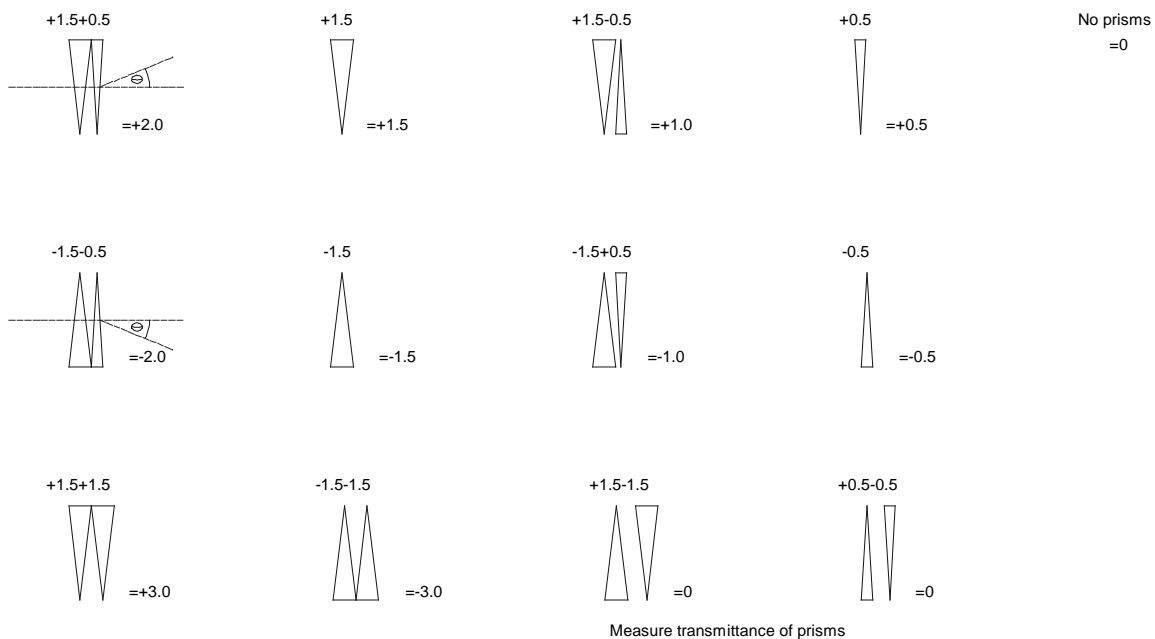

Prisms placed in front of a fresnel section optic. This will refract the beam upwards 1.5°.

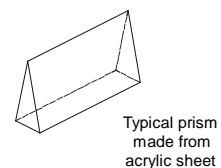

Figure 39 The use of Prisms to Divert a Beam through a Vertical Angle

9 ADDITIONAL PROCEDURES FOR “IN SITU” MEASUREMENT

In situ measurements are generally conducted on existing lighthouse optics. Because measurement sites using telephotometry should be situated on land, it should be remembered that in situ measurements are usually only feasible in one or two directions within the zone of utilisation of the light. During the course of the measurements, the operational availability of the lighthouse may be affected. Appropriate navigational warnings should be raised.

9.1 Choice of Measurement Site

The first requirement when carrying out a field light measurement is to find a suitable measurement site. This should be a site where stable mounting of the photometric equipment is possible, preferably away from any adverse conditions of weather or unwanted interference from extraneous light sources. The whole of the optic to be measured should be clearly visible from the measurement site.

Calculations of the crossover distance of the optic being measured should be made to establish the minimum photometric distance. Once this minimum is established, a measurement site should be sought which is beyond the minimum photometric distance, and within plus or minus one degree of a line between the optic centre and the horizon. This vertical tolerance of two degrees is approximate and depends on the vertical beam profile of the light to be measured. The closer the measurement site is to the nominal beam centre, the less the measurement uncertainty.

9.2 Setting Up the Telephotometer

The iris of the telephotometer should be set to accept light from the optic being measured and the reference light. The field outside that of interest should be stopped. Daytime is the best time to set up the equipment because the field of view can be easily seen and any potential obstructions accounted for.

9.3 Setting Up the Lighthouse Optic

The lighthouse optic to be measured should be inspected and cleaned. The optic type and dimensions plus any manufacturer's details should be noted, as should any faults or defects in its operation.

The optic should be outfitted with lamps that conform to design dimensions, rated power consumption, and rated lumen output. The light source should be positioned in the optic in accordance with the procedures established by the optic manufacturer and the Lighthouse Authority.

If the optic is a rotating type, with several light emitting axes, each one should be identified and numbered if not already done so by the manufacturer. This may be done by identifying a unique mark on the rotating part of the item under test (e.g. datum mark or optic door hinge) and numbering each beam or axis from there in the direction opposite to the direction of rotation.

9.4 Setting Up the Prism Frame and Prisms

Install the prism frame between the optic and the measurement site so as to include the maximum area of the lens (or lenses) as possible. Any remaining area of the emitting surface(s) should be screened to prevent light from the optic going past the outside of the frame in the direction of the measurement site (see Figure 39). It should be noted that any blanked area would increase uncertainty of beam profile measurement as upper and lower reflectors/refractors may affect the beam shape.

9.5 Setting Up the Reference Projector

A reference projector should be installed on the outside of the lantern, e.g. on the gallery handrail, as close as possible to the optic and directed towards the measurement site. The path between the reference projector and the measurement site should be free from obstructions.

9.6 Carrying Out the Measurement

Measurements may commence as soon as conditions allow. Bear in mind that zero conditions are those of ambient light, if the ambient light level is varying significantly, e.g. because of clouds passing in front of the sun, measurement uncertainties will be increased. Most field light measurements will need to be carried out at night and in good weather.

On commencement, the reference projector should first be aligned so that its beam centre is directed towards the measurement site. The amount of variation in the reference light reading will give a good indication of the suitability of conditions.

Measurements with different prisms should then be carried out to ascertain the vertical beam profile. Each set of prisms is inserted and the flash profile(s) from the optic recorded. Each measurement set should contain a sample of reference light and ambient light. The range setting on the telephotometer should be recorded.

When all relevant prism positions have been recorded, the prisms, prism frame and screening should be removed. Flashes from the unobstructed optic should then be recorded along with reference light, ambient light and photometer settings. At least three recordings of each flash profile should be taken.

A minimum of three complete measurements should be carried out for each complete character to obtain average and uncertainty values. Dominant measurement uncertainties are likely to be due to variation in light path conditions and reference light alignment. Extreme measurement distance requires a large number of repeated measurements to reduce uncertainty.

ANNEX IV DETAILED MEASUREMENT METHOD

Tristimulus Colorimetry

1 MEASUREMENT GEOMETRY

The standard arrangement for tristimulus colorimetry is exactly the same as for photometry except that the photometric receptor is replaced by a colorimetric receptor.

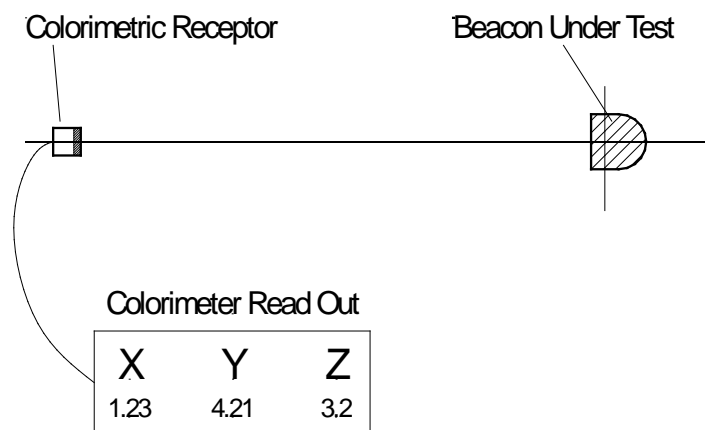

Figure 40 Standard arrangement

For light sources with a narrow intensity distribution the distance between the beacon and the colorimeter has to be increased to ensure the required high uniformity. For the optical input at the receptor, diffusers are necessary so that the light to be measured is spread over the three photodetectors with high uniformity.

To test the correct arrangement the colorimeter should be rotated in the axis. The output should not change during the rotation.

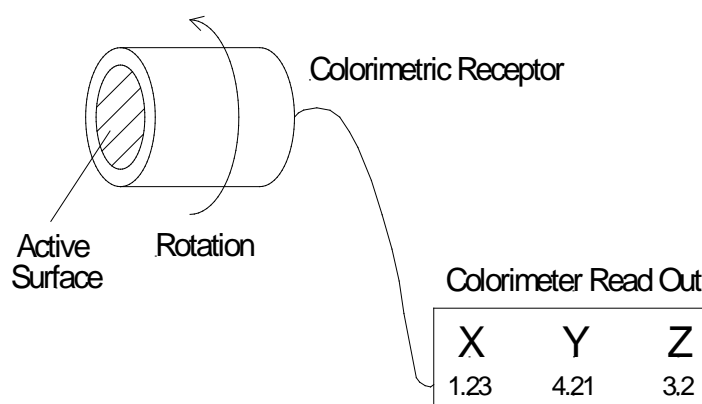

Figure 41 Simple Test for Setting Up Colorimeter

Because of the size of the area to be illuminated and the need for high uniformity, the use of a diffuser requires a relatively large measurement distance. However, most tristimulus colorimeters are fairly insensitive and the requirement for a large measurement distance precludes their use for lights with low intensities. To improve the performance of a

tristimulus colorimeter, an integrating sphere may be used. The inside of the sphere should be spectrally neutral.

Whatever method is used for obtaining a high uniformity of illuminance at the input to the colorimeter, care must be taken to ensure that any spectral distortion is accounted for.

2 APPLICATION 1

In application 1 a small integrating sphere with an aperture is used.

The light beam that reaches the aperture is measured. The integrating sphere acts as a diffuser for the light. A baffle is necessary to avoid direct light on the colorimeter. A calibration for illuminance and the calculation of luminous intensity is possible (the aperture acts as a photodetector).

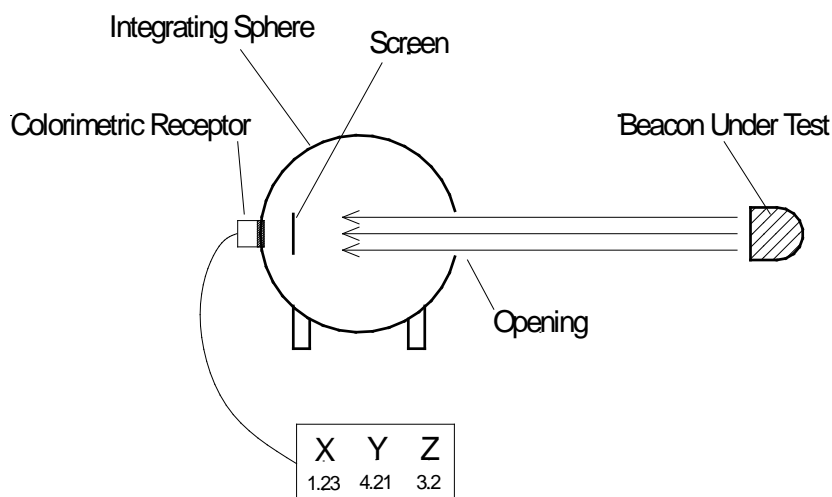

Figure 42 Beacon outside sphere

3 APPLICATION 2

The second application requires a large integrating sphere and the lantern in test is positioned inside the sphere. The average of all light is used for measurement of the colour functions. A baffle is necessary to avoid direct light on the colorimeter. A calibration for luminous flux is possible.

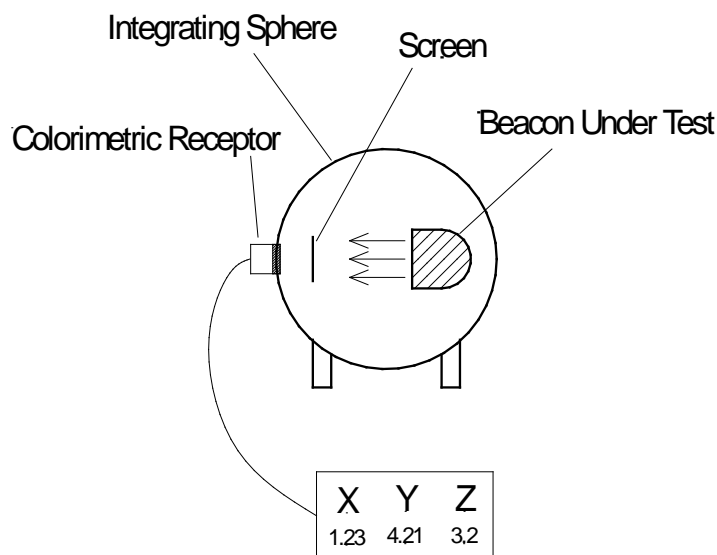

Figure 43 Beacon inside sphere

4 SPECTRUM

The spectral response of each photodetector should approximate the colour matching functions x , y , z . The residual error between the spectral response (x_C , y_C , z_C) and the colour matching functions (x , y , z) should be published in relative values for the range 380 nm to 780 nm in intervals of 10 nm:

$$r_x = \frac{\bar{x}_C - \bar{x}}{\bar{x}} \quad r_y = \frac{\bar{y}_C - \bar{y}}{\bar{y}} \quad r_z = \frac{\bar{z}_C - \bar{z}}{\bar{z}}$$

equation 19

The ultraviolet ($\lambda < 380$ nm) and infrared ($\lambda > 780$ nm) spectrum has to be suppressed to avoid errors.

In general it can be stated that the error increases when the light is near the infrared or ultraviolet. For many tristimulus colorimeter it is useful to reduce the nominal spectral range when the errors get to high.

ANNEX V DETAILED MEASUREMENT METHOD

Spectroradiometry

1 MEASUREMENT GEOMETRY

For the optical input, diffusers are necessary so that the light to be measured is spread over the input aperture with high uniformity. For light sources with a narrow intensity distribution the distance between the source and the spectroradiometer has to be adequate to ensure the required uniformity.

To test the correct arrangement the input aperture or the light under test should be rotated in the axis. The spectroradiometer output should not change as a result of the rotation.

The use of a fibre-optic bundle to couple light from the input aperture to the spectroradiometer is common.

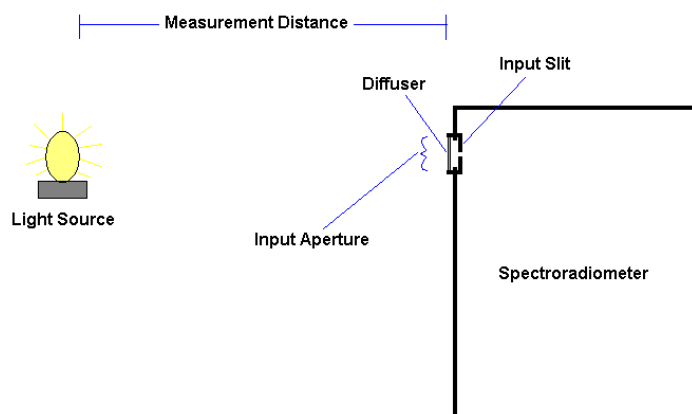

Figure 44 Spectroradiometer Measurement Geometry

2 CALIBRATION / CHARACTERISATION

In order to calibrate or characterise the spectroradiometer system, it is usually necessary to use a spectral radiance or irradiance standard lamp. This is a lamp that has been calibrated throughout the spectrum being used usually in milliwatts of power per nanometre of wavelength. The calibration file of such a lamp is usually arranged as two columns of data, wavelength and radiant power (or irradiant power per area). It is important that the resolution of the lamp calibration matches that of the measurement to be taken. Therefore, if a measurement is to be taken of a light source from 380nm to 780nm in 10nm intervals, the standard lamp should also be calibrated over that range at that interval.

The standard lamp should be placed at a distance from the measurement aperture, as specified in the lamp calibration certificate. Power should be applied as specified in the lamp calibration certificate. Then, after allowing the lamp to stabilise, a reading taken with the spectrometer. If a spectroradiometer uses charge-couple devices (CCD array) as the final detector, a note should be made of the integration period over which the spectroradiometer is taking measurements.

Once the results of the measurement are obtained, it should be compared to the similar array of data given in the standard lamp calibration certificate. By dividing the calibration figure at each wavelength with the figure obtained for that wavelength in the measurement, a correction file can be obtained. This correction file can be used to correct measurements of other light sources. If the spectroradiometer uses a CCD array, the calibration factor should include the integration time as a divisor, thereby normalising the value to one second.

Table 3 Example of a Spectroradiometer Correction File

Wavelength (nm)	Calibration Radiance (mW/nm)	Measured Radiance (raw)	Calibration Correction Factor
380	2.317801	1.3450	1.723272119
390	2.789061	1.8290	1.524910334
400	3.306898	1.1954	2.766352685
-----	-----	-----	-----
750	28.443800	34.5560	0.823121889
760	28.814490	33.2240	0.867279376
770	29.052000	31.5550	0.920678181
780	29.287460	30.3000	0.966582838

Some spectroradiometer systems have the ability to carry out corrections automatically, so that the results of the measurement show the corrected radiance or irradiance figures.

3 CARRYING OUT THE MEASUREMENT

Once the system is calibrated or characterised, the light source under test should be placed at the same distance away from the measurement aperture as the standard lamp. If, due to size constraints, the distance needs to exceed that of the standard lamp, the distance should be recorded and used to factor the measurement results using the inverse square law. However, if the measurement results are only going to be used to determine the colour of the light, no distance factoring is necessary and a relative irradiance will suffice.

The light source under test should then be lit and allowed to stabilise. Once stabilised, a measurement of the spectrum can take place recording the radiance or irradiance at each wavelength. The resultant measurement data can then be corrected using the spectroradiometer correction file. For instrument using a CCD array, normalisation of the integration time to one second should be carried out.

4 RESULTS

In order to obtain a spectral power distribution, further corrections may be necessary to correct differences in measurement distance. If an irradiance standard was used, it will be necessary to convert irradiance to radiance by multiplying the irradiance figures by the square of the measurement distance in metres. It may also be necessary to factor for wavelength if the units quoted in the standard lamp calibration certificate are different to the wavelength interval sampled during the measurement. For instance, if the standard lamp is reported in units of mW/nm, the amount of power in a measurement sample 10nm wide would be ten times that. The following formula may be used:

$$Rad = Irr \times d^2 \times WLres$$

equation 20

where:

- Rad* is the Radiance in Watts (W);
- Irr* is the irradiance in Watts per cm² per nanometre (W/cm²/nm);
- d* is the measurement distance in metres (m); and
- WLres* is the wavelength resolution or bandwidth of the each sample.

For example, the 29.28746 mW/cm²/nm shown in Table 3 relates to a standard lamp measured at 0.5 metres with a spectral resolution of 10nm. Therefore, the amount of power per 10nm would be:

$$29.28746 \times 0.5^2 \times 10 = 73.21865mW ;$$

this being the amount of radiant power in the 10nm sample between 770nm and 780nm.

5 CONVERTING SPECTRAL DATA TO COLOUR AND CHROMATICITY

The resultant SPD, whether in absolute or relative power, can be converted to colour values of X, Y and Z (see 6.5) by multiplying the power data array by the standard colorimetric observer colour functions \bar{x} , \bar{y} and \bar{z} . The resultant arrays should then each be summed to give three single values of X, Y and Z.

Table 4 Results showing Conversion from SPD to X, Y, Z colour

Wavelength (nm)	Lamp SPD	Standard Colorimetric Observer			xbar*lamp	ybar*lamp	zbar*lamp
		xbar	ybar	zbar			
380	1.57846000	0.00136800	0.00003900	0.00645000	0.00215933	0.00006156	0.01018107
385	1.73321000	0.00223600	0.00006400	0.01054999	0.00387546	0.00011093	0.01828535
390	1.89965000	0.00424300	0.00012000	0.02005001	0.00806021	0.00022796	0.03808800
395	2.07293000	0.00765000	0.00021700	0.03621000	0.01585791	0.00044983	0.07506080
400	2.25985000	0.01431000	0.00039600	0.06785001	0.03233845	0.00089490	0.15333085
-----	-----	-----	-----	-----	-----	-----	-----
740	22.47410000	0.00069008	0.00024920	0	0.015508895	0.005600546	0
745	22.69190000	0.00047602	0.00017190	0	0.010801828	0.003900738	0
750	22.87750000	0.00033230	0.00012000	0	0.007602218	0.0027453	0
755	23.06570000	0.00023483	0.00008480	0	0.005416428	0.001955971	0
760	23.19950000	0.00016615	0.00006000	0	0.003854609	0.00139197	0
765	23.38130000	0.00011741	0.00004240	0	0.002745269	0.000991367	0
770	23.52330000	0.00008308	0.00003000	0	0.001954204	0.000705699	0
775	23.69320000	0.00005871	0.00002120	0	0.001390945	0.000502296	0
780	23.80550000	0.00004151	0.00001499	0	0.000988165	0.000356844	0
Sum					X	Y	Z
					273.1761517	254.6582997	105.3921376

To convert the X, Y and Z colour values to conform to the CIE 1931 chromaticity diagram, equations 4 and 5 (see 6.5 above) should be used:

$$x = \frac{X}{X + Y + Z} \quad \text{and} \quad y = \frac{Y}{X + Y + Z}$$

Using the X, Y, Z results from Table 4, the resultant values of x and y are 0.4314 and 0.4022 respectively, when rounded off to four decimal places. This is in the IALA white preferred region.

6 CONVERTING SPECTRAL DATA TO LUMINOUS INTENSITY

The measured SPD can be converted to luminous intensity by applying the standard photopic observer function $V(\lambda)$ to the measured data and summing the result. A lumen per Watt factor of 683 is then applied to achieve a luminous intensity value.

Table 5 Results showing Conversion from SPD to Luminous Intensity

Wavelength (nm)	Lamp SPD (mW)	Standard Photopic Observer $V(\lambda)$	Combined Value
380	1.57846000	0.00003900	0.00006156
385	1.73321000	0.00006400	0.00011093
390	1.89965000	0.00012000	0.00022796
395	2.07293000	0.00021700	0.00044983
400	2.25985000	0.00039600	0.00089490
-----	-----	-----	-----
740	22.47410000	0.00024920	0.00560055
745	22.69190000	0.00017190	0.00390074
750	22.87750000	0.00012000	0.00274530
755	23.06570000	0.00008480	0.00195597
760	23.19950000	0.00006000	0.00139197
765	23.38130000	0.00004240	0.00099137
770	23.52330000	0.00003000	0.00070570
775	23.69320000	0.00002120	0.00050230
780	23.80550000	0.00001499	0.00035684
Sum			254.6582997
Factor mW to cd			683/1000
Luminous Intensity (cd)			173.9

ANNEX VI EXAMPLE OF A PHOTOMETRY UNCERTAINTY BUDGET

This example of an uncertainty budget is meant for guidance only. It has been compiled in accordance with ISO Guide No. 2 [9] and incorporates current methodologies. The model used is a simple one incorporating those inputs thought to have a significant effect on uncertainty. The model may change depending on the particular measurement method, measurement equipment or item being measured. For instance, if the same method and equipment shown in the example were used to measure a beacon with a tungsten filament lamp with a similar spectral output to that of the reference lamp, no spectral correction would be necessary. Furthermore, it can be seen from the uncertainty contributions shown in the example that the uncertainty of photometer gain has little influence on uncertainty and could possibly be excluded from the budget.

A separate uncertainty budget for each individual measurement process should be compiled if there is insufficient knowledge of the uncertainty of the result. For example, the spectroradiometer plot shown in the test report would have its own uncertainty budget for the evaluation of the spectral correction factor (SCF). This would include, as the model, the equation for determining SCF (see 4.23).

In general, if there is any doubt as to the significance of an uncertainty contribution, it should be evaluated, used if necessary or discarded if insignificant. A reduction in uncertainty should always be strived for and unnecessary sources of uncertainty should, wherever possible, be eliminated. Significant types of uncertainty and other limiting factors for two measurement methods are as follows:

1 OUTDOOR PHOTOMETRY

Uncertainties:

- establishing and measuring beyond the minimum photometric distance;
- stray and ambient light;
- photometer calibration;
- colour correction of photometer for red and green colours;
- environmental conditions.

Limiting factors:

- finding suitable dark real estate;
- obtaining sufficient meter sensitivity at the minimum photometric distance.

2 ZERO-LENGTH PHOTOMETRY

Uncertainties:

- shape, accuracy and reflectance of parabolic mirror;
- alignment and calibration of system;
- stray and ambient light;
- photometer calibration;

- colour correction of photometer (plus mirror) for red and green colours.

Limiting factors:

- cost and accuracy of parabolic mirror;
- size of specimen optic is limited to size of mirror.

Light Measurement Uncertainty

Example

Determination of luminous intensity of a light beacon by measurement of illuminance at a measured distance.

Procedure

A beacon is positioned such that its beam is projected onto the acceptance area of an illuminance meter (luxmeter) placed at a measured distance from the beacon. Five illuminance readings are taken of the beacon under test (E_{x1-5}). Ambient and stray light conditions are accounted for by occluding the direct light path between the beacon and the illuminance meter and taking further five readings (E_{z1-5}). These further readings are used as the baseline for the measurement such that $E_x - E_z = E$, where E is directly proportional to the luminous intensity of the beacon. Three measurements are taken of the distance between the beacon and the illuminance meter (D_{1-3}). When measuring luminous intensity against angular displacement, the beacon will be installed on a goniometer and five readings will be recorded for each incremented angular (goniophotometric) position. Five illuminance readings of ambient and stray light will be recorded before the goniophotometric process commences.

The illuminance meter spectral response does not exactly follow $V(\lambda)$ and this can lead to a measurement error if the spectral output distribution of the beacon being measured and the light source used to calibrate the illuminance meter are different. If the spectra are different, a spectral correction factor (SCF) and its uncertainty should be determined separately and applied. If the spectra are similar, the $V(\lambda)$ closeness of fit figure (f1') for the illuminance meter can be used as the measurement uncertainty associated with SCF, SCF itself being unity.

Measurement Model

$$I = (E_x - E_z) \cdot SCF \cdot D^2$$

Measurement Quantities

Output Quantity - Mean value of I, and uncertainty $u(I)$, is the output quantity of the luminous intensity, in candelas, of the beacon under test.

Input Quantity 1 - Mean value of E_x , and uncertainty $u(E_x)$, is the input quantity of the illuminance meter reading in lux proportional to the beacon light output plus stray and ambient light.

Input Quantity 1 - Mean value of E_z , and uncertainty $u(E_z)$, is the input quantity of the illuminance meter reading in lux proportional to the stray and ambient light.

Input Quantity 2 - SCF, and uncertainty $u(SCF)$, is the input quantity of the spectral correction factor determined separately.

Input Quantity 3 - D, and uncertainty $u(D)$, is the input quantity of the measured distance between the beacon under test and the acceptance plane of the illuminance meter

Recommendation E-200-3 – Measurement
December 2008

Measurement Input Data

Inputs	Description	Readings	Data Handling	Value	Standard Uncertainty	Notes
E_{x1} Lux	Five raw illuminance meter readings of beacon (in lux - inc. stray and ambient)	8.44	Example result of five measurements Mean $E_x = (E_{x1} + E_{x2} + E_{x3} + E_{x4} + E_{x5})/5 \pm u(E_x)$ Lux	8.38	0.0214	Type A - normal distribution - standard uncertainty taken from 5 readings
E_{x2} Lux		8.36				
E_{x3} Lux		8.38				
E_{x4} Lux		8.32				
E_{x5} Lux		8.42				
E_{z1} Lux	Five raw illuminance meter readings of stray and ambient light (in lux - direct light path occluded)	0.10	Example result of five measurements Mean $E_z = (E_{z1} + E_{z2} + E_{z3} + E_{z4} + E_{z5})/5 \pm u(E_z)$ Lux	0.15	0.0245	Type A - normal distribution - standard uncertainty taken from 5 readings
E_{z2} Lux		0.20				
E_{z3} Lux		0.10				
E_{z4} Lux		0.20				
E_{z5} Lux		0.10				
$E \pm 2.00\%$	Illuminance meter uncertainty quoted on calibration certificate				1.00%	Type B - normal distribution - expanded uncertainty from calibration certificate divided by the coverage factor (e.g. $k = 2$)
$SCF = 1 \pm 0.03$	Spectral correction factor - for illuminance meter		SCF $\pm u$ (SCF) the standard uncertainty from separate measurement of spectral distributions (see BS667:1996)	1	1.50%	Type B - normal distribution - <i>Note: Provided the spectral output of beacon and illuminance meter reference are similar, $u(SCF)$ can be the 'f1' figure and SCF made unity.</i>
D_1 metres	Three measurements of distance between beacon and illuminance meter	25.005	Example result of three measurements Mean $D = (D_1 + D_2 + D_3)/3 \pm u(D)$ metres	25.000667	0.002603	Type A - normal distribution - standard uncertainty taken from 3 readings
D_2 metres		25.001				
D_3 metres		24.996				
$D \pm 2\text{mm}$	Measuring device uncertainty quoted on calibration certificate or minimum resolution (e.g. 2mm)				0.001155	Type B - rectangular distribution - resolution of measuring device divided by <i>square root of 3</i>

Sensitivity Coefficient (output : input)

Input No.	Derivation	Formula	Coefficient
c1	I/E _x	= SCF D ²	625.0333338
c2	I/E _z	= SCF D ²	625.0333338
c3	I/SCF	= E D ²	5234.65417
c4	I/D	= E SCF D	209.3805833

Uncertainty Budget

Input Quantity	Quantity Name	Symbol	Quantity Value	Standard Uncertainty <i>u</i> _(input)	Type of Evaluation	Degrees of Freedom <i>v</i> _(input)	Sensitivity Coefficient <i>c</i> _(input)	Uncertainty Contribution <i>u</i> _{I(output)} cd
1	Beacon Illuminance	E _x	8.38	0.021354	A	4	625.0333	13.347060
				0.001194	B	infinity	625.0333	0.746308
2	Ambient & Stray Illuminance	E _z	0.15	0.024495	A	4	625.0333	15.310127
				0.001194	B	infinity	625.0333	0.746308
3	Spectral Correction Factor	SCF	1.00	0.015000	B	infinity	5234.65417	78.519813
4	Distance	D	25.0006667	0.002603	A	2	209.38058	0.545105
				0.001155	B	infinity	209.38058	0.241772
Outputs	Beacon Intensity	I	5140.89917		<i>v_{eff}</i>	1891	Combined Uncertainty <i>u_c(output)</i>	80.0042

Degrees of Freedom (ν_{eff}) and Coverage Factor (k)

ν_{eff} = 1891 from Welch-Satterthwaite **note: should be >100 for coverage factor of 2**
k = 2 this is the coverage factor for 95% confidence from *t*-distribution chart

Expanded Uncertainty

$$U_{(output)} = k \cdot u_{(output)} = 2 \times 80.0042 = 160.01 \text{ cd}$$

Reported Result

Luminous Intensity of Beacon (I) = 5141 +/-160 cd

The reported expanded uncertainty of measurement is stated as the standard uncertainty of measurement multiplied by the coverage factor k which corresponds to a coverage probability, or confidence, of approximately 95%. The standard uncertainty has been determined, as far as practicable, in accordance with ISO Publication No. 2 1993 "Guide to expression of uncertainty in measurement".

Comments

The following uncertainties have not been considered in this measurement process but may be considered if thought to give a significant contribution:

1. Effects of angular alignment (usually cosine related)
2. Effects of temperature on measurement of distance and illuminance meter performance (from calibration certificate)
3. Effects of long term drift (over time, the calibration certificates and measurement data can be used to provide an assessment)

References

1. SIRA: "Practical Approach to Uncertainties in Measurement", 2002
2. CIE TC 2-43: "Determination of Measurement Uncertainties in Photometry", Expert Symposium 2001
3. ISO Publication No. 2: "Guide to the Expression of Uncertainty in Measurement", 1993