

9 Construction



1

2

3

4

5

6

7

8

9

10

CHAPTER 9 CONTENTS

9.1 Project preparation	1074
9.1.1 Construction issues	1074
9.1.2 Miscellaneous site issues	1075
9.1.2.1 Location	1075
9.1.2.2 Logistics	1076
9.1.2.3 Legal aspects	1076
9.1.2.4 Environmental aspects	1076
9.2 Site preparation	1077
9.2.1 Stockpile and repair areas	1077
9.2.1.1 Location, layout and size	1077
9.2.1.2 Operational and safety requirements	1079
9.2.2 Loading and unloading facilities	1080
9.2.2.1 Loading of barges	1080
9.2.2.2 Loading of coasters	1084
9.2.2.3 Loading of lorries and trains	1084
9.2.2.4 Additional considerations for unloading	1084
9.3 Equipment	1086
9.3.1 General	1086
9.3.2 Land-based equipment – dumping of material	1087
9.3.3 Land-based equipment – controlled placement	1090
9.3.4 Waterborne equipment – dumping of material	1093
9.3.5 Waterborne equipment – controlled placement	1094
9.3.6 Working conditions	1099
9.3.6.1 Working conditions for land-based operations	1099
9.3.6.2 Working conditions for waterborne operations	1100
9.3.7 Tolerances	1106
9.4 Transport	1109
9.4.1 Road transport	1110
9.4.2 Rail transport	1113
9.4.3 Waterborne transport	1114
9.4.3.1 Marine transport	1114
9.4.3.2 Transhipment to the shore	1116
9.5 Constructon risk and safety	1118
9.5.1 Introduction	1118

9.5.2	Key hazard sources and their delivery	1118	1
9.5.2.1	The uncertain environment	1119	
9.5.2.2	The dynamic physical environment	1121	
9.5.3	Principles of good practice for risk management	1121	2
9.5.3.1	Protecting the works	1121	
9.5.3.2	Protecting the operative	1124	
9.5.3.3	Protecting the public during construction	1125	
9.5.3.4	Selecting and using plant and equipment	1126	
9.5.3.5	Summary of good practice	1126	
9.6	Ground and soil issues	1127	3
9.6.1	Ground conditions	1127	
9.6.2	Erosion and sedimentation	1127	
9.7	Work methods	1128	4
9.7.1	Bed and bank protection works	1128	
9.7.1.1	Types and functions	1128	
9.7.1.2	Bed protection works	1129	
9.7.1.3	Bank protection works	1133	5
9.7.2	Construction of breakwaters	1135	
9.7.2.1	General	1135	
9.7.2.2	Land-based breakwater construction	1136	
9.7.2.3	Waterborne breakwater construction	1142	6
9.7.2.4	Combination of land-based and waterborne construction	1144	
9.7.2.5	Use of land-based <i>versus</i> waterborne operations – summary of issues	1145	
9.7.2.6	Placement of concrete armour units	1146	
9.7.3	Construction of seawalls	1147	7
9.7.4	Offshore and foundation structures	1149	
9.7.4.1	Construction of foundation structures	1149	
9.7.4.2	Construction of pipeline and cable protection	1150	
9.7.5	Typical river works	1151	8
9.7.5.1	Bank protection on sandfill	1151	
9.7.5.2	Spur-dikes and river alignments	1152	
9.7.6	Execution of emergency repairs	1153	
9.8	Quality control	1154	9
9.8.1	Placing methods and packing	1154	
9.8.1.1	Armourstone	1154	
9.8.1.2	Concrete units	1155	
9.8.2	Checking panel density by panel surveys with block count method	1157	10

9.8.3	Quality control during construction.	1157
9.8.3.1	General aspects of quality assurance	1157
9.8.3.2	Quality control of materials on construction site.	1160
9.8.4	Test panel calculations and payment issues	1162
9.9	Survey and measurement techniques.	1164
9.9.1	Survey control	1165
9.9.2	Pre-construction survey drawings.	1165
9.9.3	Alignment of structure	1166
9.9.4	Setting out of profiles	1166
9.9.5	Armour unit pattern placement	1166
9.9.6	Roundhead setting out	1167
9.9.7	Underwater construction	1167
9.9.8	Survey techniques	1168
9.9.8.1	Above water.	1168
9.9.8.2	Under water	1170
9.10	References	1175

9 Construction

Chapter 9 discusses construction plant and methods.

Key inputs from other chapters

- Chapter 2 ⇒ **project requirements**
- Chapter 3 ⇒ **material properties**
- Chapter 4 ⇒ **physical site conditions**
- Chapter 6, 7 and 8 ⇒ **structure design**

Key outputs to other chapters

- **construction methods and constraints** ⇒ Chapters 6, 7, 8 and 10.

NOTE: The project process is **iterative**. The reader should **revisit Chapter 2** throughout the project life cycle for a reminder of important issues.

This flow chart illustrates where to find information in the chapter and how it links with other chapters. Use this with the contents page and the index to navigate the manual.

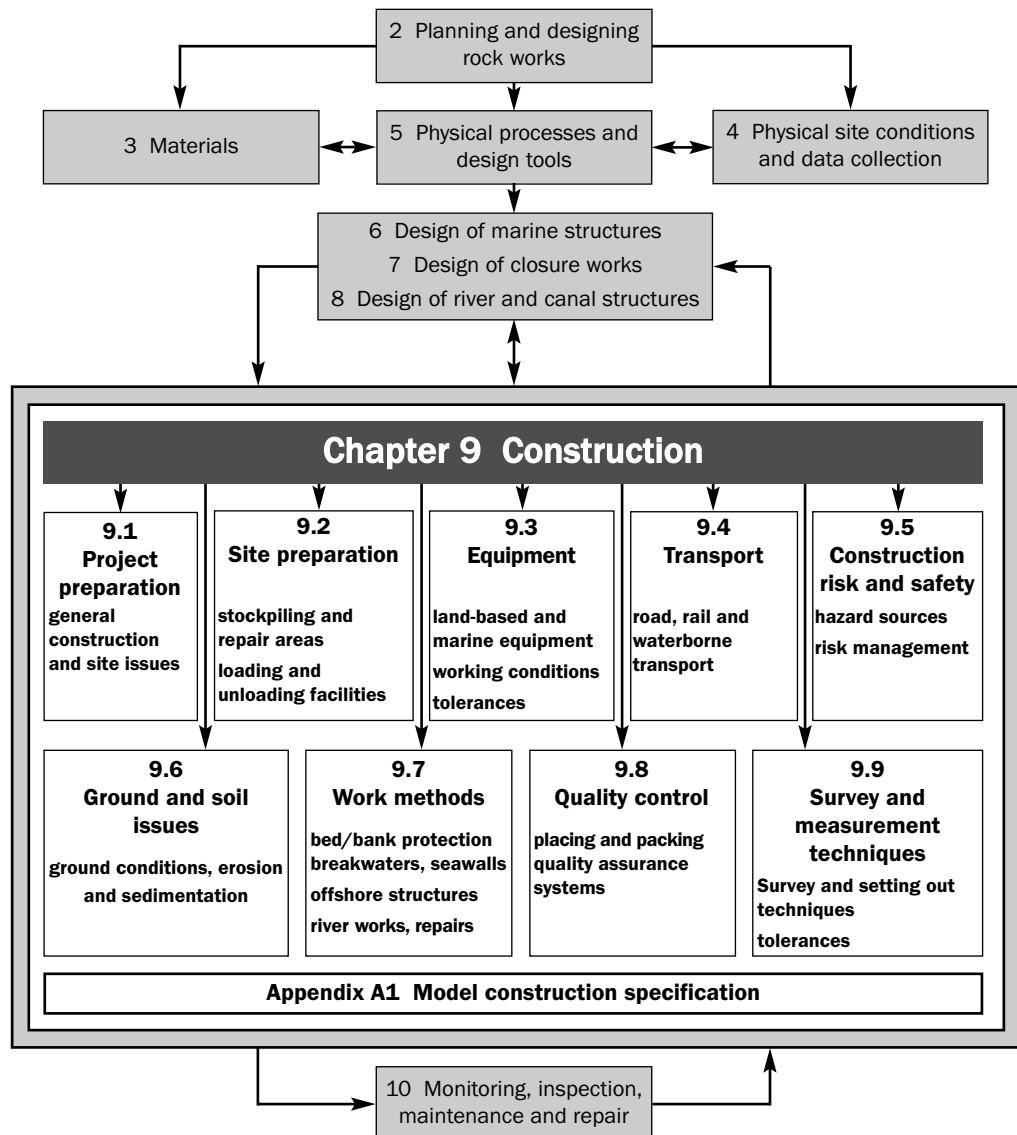

This chapter discusses the construction aspects of hydraulic structures involving the use of rock. Particular emphasis is placed on the practical aspects of armourstone projects, which are considered in combination with the theoretical aspects of rock and quarry production techniques discussed in Section 3.9. The general flow chart at the start of this chapter indicates how this chapter cross-refers to other chapters in the manual.

The main topics discussed in this chapter are:

- project preparation (construction issues)
- site preparation
- review of commonly used equipment
- transport of stones
- construction risk and safety
- geotechnical issues
- construction methods for common hydraulic structures
- survey and measurement techniques
- quality control, including aspects relating to placing and packing.

The main sections of this chapter, from project preparation to work methods and survey and measurement, are set out in the flow chart below, Figure 9.1.

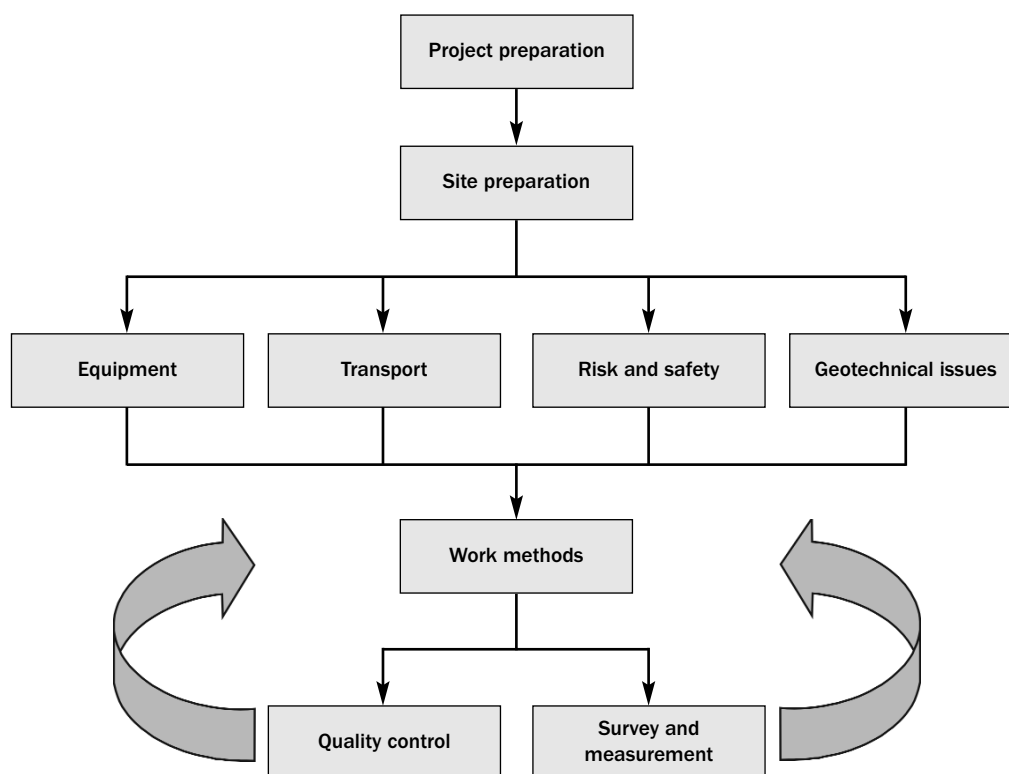

Figure 9.1 Relationship between sections of this chapter

Construction methods for the following hydraulic structures involving the use of rock are discussed:

Category	Cross-references to other sections of this manual
Bed protection works	6.1, 6.2, 6.3, 8.3
Bank protection works and revetments	6.2, 6.3, 8.2, 8.3
Rubble mound breakwaters	6.1
Shore protection works	6.3
Pipelines and foundations	6.4
Spur-dikes, river alignment structures	8.2
Abutments and pier foundations	8.5

These structures are built using either land-based or waterborne equipment. As part of the selection procedure for the correct type of equipment and construction method, all structures should be evaluated with respect to:

- dimensions and layout
- volumes and types of armourstone required
- temporary stone storage facilities at the site
- quarry location and production
- transportation from quarry to site
- accessibility of the works for both land-based and waterborne equipment
- external conditions affecting the workability – water depth both for access and construction, wave and wind conditions and their seasonal variations, tides and currents, temperature and visibility
- stability of the structure in its partially completed state.

Because specific conditions apply for every structure, the construction method needs to be tailored to the project. Some project examples are illustrated in this chapter, but methods often vary from contractor to contractor, depending upon the type of plant they own and their previous experience.

Design may be affected by a variety of limitations, including:

- requirements to prevent water and air pollution, including ecological aspects, noise limitations and traffic restrictions (see Section 2.5)
- availability of equipment and labour
- level of local experience with comparable construction works
- infrastructure (roads, railways, ports)
- facilities for future maintenance
- financial constraints
- seasons in which the work will be executed
- availability of suitable armourstone or rock source.

It is important to note that construction methods cannot be learnt from this manual alone. Practical site experience is necessary, too. Understanding all aspects of work management requires experience of numerous projects and the guidance of experienced senior personnel.

9.1 PROJECT PREPARATION

9.1.1 Construction Issues

Depending on the type of construction project and its location (whether it is in a rural or urban area, for example), the issues listed in Table 9.1 should be taken into account. The list can be used as a guideline but it is not exhaustive nor will all aspects be relevant when starting a project.

Table 9.1 Construction issues

Aspect	Issues
Equipment (see Section 9.3) Vessels, auxiliary equipment, pontoons, trucks, hydraulic excavators, site offices	<ul style="list-style-type: none"> ● appropriate equipment available ● technical specification ● adequate spare parts ● safety ● maintenance area, maintenance personnel
Sub-contractors and suppliers	<ul style="list-style-type: none"> ● level of experience and expertise ● equipment available ● insurance cover in place ● reliability
Personnel	<ul style="list-style-type: none"> ● organogram (roles and responsibilities) ● availability of qualified personnel ● adequate staff levels ● continuous overlapping day and night shifts ● need for long working hours
Quarry (see Section 3.9)	<ul style="list-style-type: none"> ● geotechnical investigation ● existing quarry or new quarry ● ability to meet specification ● suitable equipment available ● production capacity and exploitation plan
Transport (see Section 9.4)	<ul style="list-style-type: none"> ● appropriate equipment available ● capacity (matching supply to demand) ● manoeuvrability ● draught ● contingency plans ● collecting and processing haulage data
Stockpiling at site and at the quarry (see Section 9.2.1)	<ul style="list-style-type: none"> ● capacity ● stability ● efficient layout routeing to improve performance ● environment ● public
Construction (see Sections 9.6 and 9.7)	<ul style="list-style-type: none"> ● site investigation ● access ● infrastructure – roads, telephones, water, sewerage, access near children's play areas and schools etc ● means of construction and work methods ● safety ● waves, tides, currents ● wind and weather ● time of year ● surveying (agree methods with client) and tolerance levels ● temporary works ● turbidity of surroundings ● contamination ● hydrostatic pressure ● consolidation and settlement
Survey (see Section 9.9)	<ul style="list-style-type: none"> ● choice and calibration of survey equipment ● agree system with client or use same equipment as client

Table 9.1 Construction issues (contd)

Aspect	Issues
Planning (see Section 9.8.2)	<ul style="list-style-type: none"> regular reporting clear planning distributed to all involved parties detailed flexible plans (24 hours in advance)
Risk analysis (see Section 9.5)	<ul style="list-style-type: none"> materials labour and plant financing planning risk in partially completed state of the works emergency planning and contingencies
Health and safety (see Section 9.5)	<ul style="list-style-type: none"> adherence to national and company regulations for all safety aspects safety of the public
Environmental aspects	<ul style="list-style-type: none"> dust noise pollution ecology water and air quality and contamination local wildlife habitats
Statutory bodies and other parties	<ul style="list-style-type: none"> fishing industry emergency services such as coastguard, ambulances, lifeboat and police nature conservationists heritage conservationists port and naval authorities leisure and amenity users public consultation

9.1.2 Miscellaneous site issues

Any construction project will need a temporary site close to the construction area to house site offices, service and repair yards, temporary fabrication areas and staff welfare facilities. Its location is likely to have legal and cost implications, such as the need for planning permission, the proximity of welfare facilities, land rental and the existence of supporting infrastructure. The temporary site should therefore be considered early in the project planning stage.

9.1.2.1 Location

Regardless of the size and the location of the contract, attention will have to be paid to the external constraints and the capacity of the infrastructure. An area will need to be chosen, too, for setting up site offices, welfare facilities, car parking, manufacturing requirements, repair yards etc.

Infrastructure includes:

- roads, ports and railways
- telecommunications
- water, sewerage and electricity
- security
- lighting for 24-hour working.

External considerations include:

- noise** – be aware of all noise restrictions before the tender date, because they can limit working time and thereby increase project cost; noise considerations may affect the use or positioning of generators

- local **amenities** – may need to be moved or compensation paid if they can no longer be used
- **dust** or other emissions – may make the preferred temporary site unsuitable (**NOTE:** This should not be confused with the construction area)
- **security** of the preferred temporary site
- **planning** – the need for planning permission for the temporary site as well as for the construction site.

Involving users and the relevant authorities at an early stage should help to minimise the risk of problems and lead to the best location for the temporary site being identified.

9.1.2.2 **Logistics**

Logistics encompass all elements and activities essential to the efficient transportation of materials within a project, covering:

- plant and equipment, including fuel and other supplies
- test laboratory for materials
- personnel
- consumables
- work programmes
- studies and expertise.

9.1.2.3 **Legal aspects**

Taxes may have to be paid or specific authorisations may be required for the transportation of materials and the execution of the works. Those most frequently encountered are:

- **harbour tariffs** – merchant ships unloading, loading or transferring goods or passengers within the harbour limits may have to pay dues
- **navigation charges** – ships entering a harbour or restricted navigational area may need to use pilots and adhere to local navigational rules that may affect the delivery programme
- **boatman charges** – ships mooring in a harbour may be obliged to call upon a boatman or stevedoring company to handle mooring ropes and cargo
- **navigation authorisations** – eg entrance, fairway crossings and anchorage, leading to a navigation notice
- **notices to mariners.**

9.1.2.4 **Environmental aspects**

Dust

The production process in the quarry often produces dust, particularly during stone-handling on the stockpile(s) and during transport along unpaved roads. The amount of dust generated depends on the rock quality, the crushing and screening method and the handling. To protect the surrounding areas from dust, stockpiles should, wherever possible, be located downwind of sensitive areas and kept wet using sprinklers or water bowsers. Care should be taken to avoid over-watering and causing slurry, which could cause problems should it reach the public highway. As a remedial solution, unpaved roads may be watered.

Noise

Noise is generated in the quarry by blasting, crushing, breaking and operating plant, although these activities are restricted by the quarry's planning permission. Transport and

handling also create noise. Local restrictions may be imposed on operations and may include bans on night-time and/or weekend working. The restrictions are likely to vary according to whether the location is rural or suburban and may also affect waterborne delivery.

Ecology

All armourstone contains a small proportion (0.25–0.5 per cent of volume) of fines and individual pieces of broken stone will be encrusted with fines. When the armourstone is being discharged and placed in the water these fines may cause turbidity. Once submerged, they will wash away and disperse. The consequence on local ecology and hydraulic conditions should be monitored. This is a greater problem when working within enclosed dams and waterways with low fluvial movement. To increase acceptability, the public should be made aware that dust may lead to temporary discoloration of the water. The use of waste materials may also affect the ecology. Note that in some countries it may be necessary to submit a declaration of immersion and meet *ad hoc* specifications on turbidity levels.

Water quality

The use of recycled and secondary materials, including certain types of slag and mine waste (see Section 3.13), may be restricted in certain areas to avoid pollution of surface water and groundwater and loss of amenity. The risk of oil spills and other forms of contamination must also be minimised.

Public

Experience indicates that if the public are kept well informed they are more likely to accept a project. Information can be imparted through public meetings and site visits, or via newsletters, newspaper articles or advertisements, dedicated websites, notice-boards, meetings and school visits. To ensure public safety, consideration should be given to fencing the site zone (in many countries this is an obligation). Although disruptions to local transport may be unavoidable, it is often possible to establish alternative routes, which should be clearly indicated and the public informed of them.

9.2 SITE PREPARATION

9.2.1 Stockpile and repair areas

9.2.1.1 Location, layout and size

Stockpiles may be located in the quarry, at the railway depot or loading and unloading location, within the port and on the construction site. *Wet stockpiles* located in water near the construction site are also an option, but in this case it should be borne in mind that material finer than 300 kg may be lost. The choice of the location and the number of stockpiles is determined by the logistics of the chosen method. The size of a stockpile depends on the quarry's production capacity, the lead-time for the production of the first consignment of armourstone, the transport capacity and the construction capacity.

Quarries tend to have a fairly constant weekly output that is governed by the frequency of blasting, capacity of handling plant and other commitments (see Section 3.9.6).

Site requirements may vary significantly depending on the construction stage. At the start of a project, bulk dumping by split-hopper barge normally uses far more armourstone per week than in the later project phases, when individual armourstone blocks are positioned individually.

Site planning should take account of this variation in requirements and the overall demand should be smoothed out as much as possible to avoid excessive peaks and troughs occurring. Complete compatibility between quarry output and site requirements is seldom achieved, however, and buffer stockpiles are usually required.

Figure 9.2 shows how the size of a stockpile can be calculated by simply plotting quarry output and site requirements on the same tonnage/time graph. The periods during which the site requirement, shown as construction capacity, exceeds the production capacity of the quarry are the ones that dictate the need for stockpiling. This can take the form of a lead-in time, t_0 , for the quarry before construction starts, the material produced during the lead-in being stockpiled.

A similar graph showing delivery capacity versus construction requirement will determine whether the stockpile should be kept in the quarry or delivered to the site and stocked there. The same considerations apply to all grades of material. This is important when a single quarry is supplying all grades and the required output of armourstone is dependent on the production of large quantities of smaller materials.

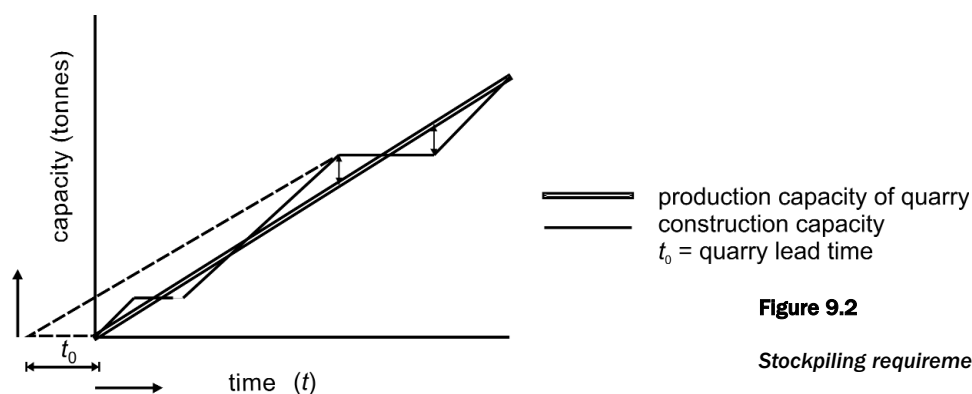

Figure 9.2

Stockpiling requirements

The dimensions of the stockpile are directly related to the quantity of armourstone, and the size of the stockpile area relates to the size of each grading. In restricted areas stockpiles may rise to considerable heights. One criterion is whether a dump truck can drive on the material in a stockpile of coarse and light gradings, a limiting factor being the rock strength. This is generally the case for gradings smaller than 5–40 kg, in which case the height is determined by:

- the gradient of the access road to the stockpile, maximum slopes being approximately 1:15
- segregation – the problem of bigger stones rolling down the slope can be eliminated by building up the stockpile in 4–5 m layers
- windblown dust in exposed areas (the nuisance can be reduced by spraying with water) and other environmental impacts (see Section 2.5)
- subsoil – bearing capacity and stability.

Stockpiles of gradings above 10–60 kg can only be as high as the reach of the available wheel loader or hydraulic excavator, which is typically 3–3.5 m for wheel loaders and 4.5–5.5 m for excavators.

To avoid cross-contamination between different grades of material, sufficient space and/or partition screens are used to separate the various stockpiles. If light and heavy gradings are placed next to each other the difference in the size of the materials will be obvious and any mixing will be noticed immediately.

Table 9.2 shows approximate quantities that can be stockpiled per hectare, excluding any partition lanes and/or roads.

Table 9.2 Approximate armourstone quantities that can be stockpiled per hectare

Grading		Tipping only [tonnes/ha]	Tipping + stacking [tonnes/ha]
Heavy gradings	6–10 t	15 000	40 000
	3–6 t	20 000	45 000
	1–3 t	25 000	50 000
Core material	1–500 kg	110 000	
Coarse grading	45/250 mm	100 000	

The location of the stockpile area in relation to the loading/unloading point is important. If delivery is by waterborne transport and the stockpile is situated near the loading area, wheel loaders can be used to carry the heavy gradings to and from the vessels. To facilitate loading and carrying, the stockpiles of heavy gradings should be set up closest to the quay wall. Coarse and light gradings can be kept further away, as they will be transported in dump trucks.

NOTE: the quay structure will need to be assessed to ensure it can accommodate the stockpile loadings (see also Section 9.2.2).

Minor repairs and maintenance work can be accomplished on site for both land-based equipment and waterborne plant. The transport and handling of armourstone cause considerable wear and tear on equipment and truck bodies, and stone skips will also need extensive repairs. This work can often be completed in a local workshop. For waterborne plant, a facility for small repairs and maintenance can be established in a nearby port or in a temporary construction harbour. This yard should also be able to handle other equipment used on the construction site such as cranes, bulldozers or loaders.

When land-based equipment is working in the tidal zone at low water, it is essential to have available emergency repair tools and/or towing equipment to recover broken-down machines before they are submerged by the tide.

9.2.1.2 Operational and safety requirements

The requirements for loading, unloading and stockpiling vary with the mode of transport and the facilities available, but certain elements of good practice in terms of housekeeping, quality control, and health and safety are common to all systems:

- where possible, the area selected should be on level ground, free from obstructions, underground services and debris. This is particularly important when cranes are to be employed
- unauthorised pedestrian access should be prevented
- to prevent cross-contamination of the different gradings of armourstone, the surface should be levelled with clean sand
- areas must be well-lit at night
- sufficient space should be made available to allow stockpiling of materials in clearly designated grades, without overlap
- loading plant should be maintained in an adequate state for loading the grades of material required, equipped with mandatory safety equipment to protect both the driver and all other operatives in the vicinity, and should have a capacity equal to the requirements of the transport vessel, eg able to load at 300 tonnes per hour. Where possible, suitable back-up plant should be available nearby

- if possible, a one-way rotation system should be instituted for controlling traffic
- mobile equipment should have audible warning reversing sirens and cameras
- only suitably trained personnel should be involved in the loading operation, both to safeguard health and safety and to ensure quality control
- all personnel must wear statutory high-visibility personal safety equipment
- close access to weighbridges or other suitable weight-monitoring equipment will prevent overloading and can be used for payment purposes
- each vehicle, vessel or train leaving the loading area should be issued with clear documentation on the type of product it is carrying, its source, quantity, date, means of transport etc
- the location should be chosen with regard to safeguarding habitat and environmentally sensitive areas
- paved and suspended quay areas should be checked against the possibility of collapse under the superimposed loadings
- the area should be checked for services, to avoid the risk of damage.

9.2.2 Loading and unloading facilities

Loading and unloading require both infrastructure and equipment. This section focuses on facilities rather than plant and equipment, but cross-references are provided to Section 9.3, in which plant and equipment for handling armourstone and related materials are discussed in detail.

Loading of vessels is often a 24-hour operation, unless the tidal range is such that high or low water does permit it. Normally several teams are required to allow for continuous or variable working times.

9.2.2.1 Loading of barges

Flat-top barges (see Figure 9.11) can be loaded by:

- dump trucks (see Figures 9.12) and wheel loader, if required
- wheel loaders (both for loading and transport) (see Figure 9.13).

The size of the barge governs the size of equipment to be used. The size of the machines used will depend on the available deck area and the strength of the deck. The following combinations of barge and vehicle sizes are frequently, but not invariably, used:

1800 t flat-top barge	30 t wheel loader and 25 t articulated dump trucks (ADTs)
3000 t flat-top barge	30 t wheel loader and 30 t ADTs
4500 t flat-top barge	30 t or 50 t wheel loader and 35 t off-highway dump trucks
9000 t flat-top barge	40 t or 50 t wheel loader and 50 t off-highway dump trucks
18 000 t flat-top barge	40 t or 60 t wheel loader and 80 t off-highway dump trucks.

Material can either be driven on board by wheel loaders or dump trucks, determined by the equipment available and the distance between the stockpiles and the quayside. Armourstone above 1 t should not be dumped on the deck of a barge but driven on board using a wheel loader – direct tipping of larger boulders will damage the deck unless it is reinforced with additional steel plates to withstand such stresses. This can accelerate the loading cycle but also increases the cost. Alternatively, if the stockpiles are far from the quayside and no adjacent tipping area can be found, a hydraulic excavator can be positioned to lift the larger stones from the dump trucks, although this is a slow process.

Wood, concrete, asphalt and additional steel plates can all be used to protect the deck of a barge, but placing and maintaining a protection layer is costly. Deck protection helps to safeguard against the damaging effects of loading equipment such as plates bending between support ribs of the deck, which can lead to a washboard effect. In addition, tipping large stones damages the deck protection. It is simple economics either to use a deck protection or to pay the owner for the damage caused to the deck as dictated in standard charter agreements.

A large wheel loader loading or carrying from a stockpile over a distance of about 300 m operates at between 14 and 16 cycles per operational hour.

Access to the barge is usually by means of a linkspan or loading ramp. Those responsible for the loading should look at the following issues to determine whether wheel loaders or dump trucks can drive on to the barge:

- the freeboard of the barge when empty or full
- the height of the quay wall above the waterline
- the tidal range
- the ballasting capacity of the barge.

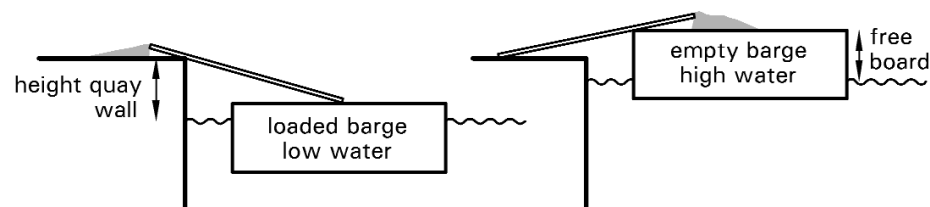

Figure 9.3 *Inclination variation due to tide and loading condition*

When the height difference allows, the simplest way to provide access is to use either heavy wooden planks or purpose-made steel ramps. Before commissioning the construction of the ramp, it is important to consider the weight of the plant, the vehicle width (measured from tyre to tyre; the width of the ramp should be 1.5 times the wheel span) and the length required. The inclination of the ramp should not be more than 20 per cent. In practice this means a maximum height difference between quay and barge of 1.5–2 m, both up and down (see Figure 9.3). It is important that both ends of the ramp be adequately embedded, for example by sub-base or sand, so that it cannot be moved by the tyres of the loading equipment and to avoid bouncing against the ridge of the ramp. A small heap of material on the deck of the barge and on the quay wall should be sufficient and will allow the ramp to move freely, thus minimising the risk of damage (see Figure 9.3).

High tidal ranges, high quay walls and vessels with low freeboard all necessitate the addition of an intermediate step to bridge the height difference (see Figure 9.4).

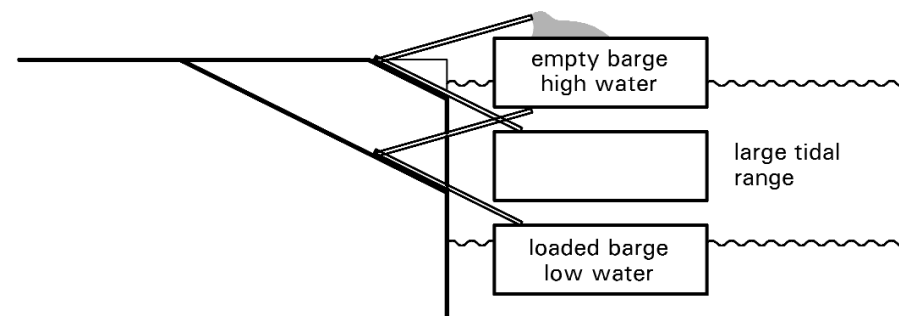

Figure 9.4 *Bridging height differences*

Where it is not possible to use the above method, or when it is necessary to reach deeper water further away from the quay wall, a floating linkspan attached to a small free-floating barge should be considered (see Figure 9.5).

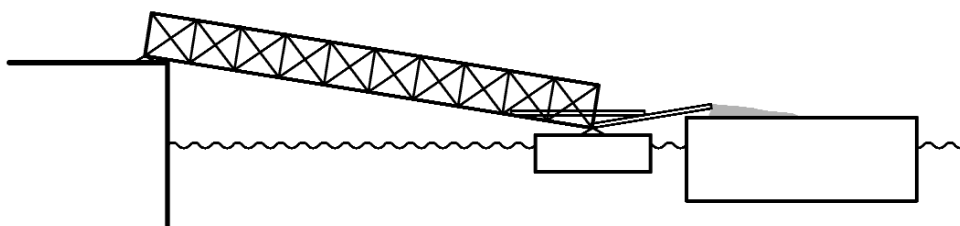

Figure 9.5 Linkspan with free-floating barge

The size of the barge, linkspan and the size and gross weight of the loading equipment used should be taken into account when determining which equipment to use.

Allowing one truck at a time, the cycle time for driving on to the barge, turning, tipping and driving off the barge determines the achievable loading rate. For example, with a cycle time of 150 seconds (2.5 minutes), approximately 20 cycles per hour are possible with an efficiency of some 80 per cent. The loading rate is then: $20 \times 25 \text{ t (load capacity of truck)} = 500 \text{ t/h}$.

To achieve a full load of armourstone, regardless of whether the load is large or small, it is recommended that a wheel loader be used occasionally to stack the material to the maximum level (see Figure 9.6). When wheel loaders are used to load and carry or when dump trucks are unloaded with hydraulic excavators (see Figure 9.7b) material should be stacked immediately. The loading should take place under the direction of the bargemaster, who is responsible for the loaded quantity and the stability of the barge.

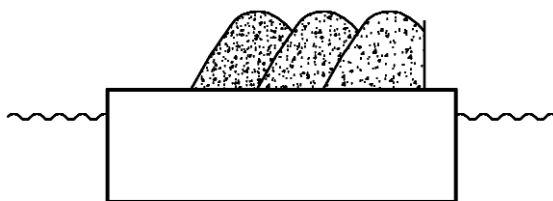

Figure 9.6 Stacking stone material on a barge

For small material, such as filter material and quarry run (up to 300 kg), direct dumping from the trucks via a chute is possible (see Figure 9.7a). Alternatively, when loading larger stones or if there is a risk of damage to the deck of the vessel, the materials can be placed on to the vessel by using a hydraulic excavator (see Figure 9.7b). This system can also be used to load flat-top barges although in this case, the excavator needs additional assistance from a wheel loader on the flat-top barge to distribute and stack the material to avoid frequent repositioning of the barge.

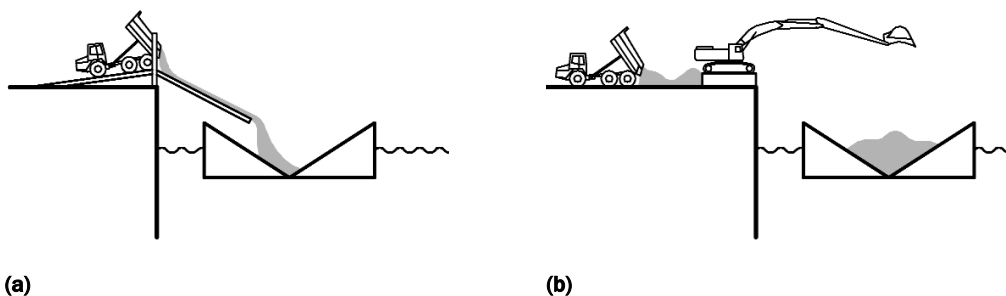

Figure 9.7 Placing stone material into a barge

Small-sized material of more than 200 mm and up to about 10 kg can be loaded with a conveyor belt system (see Figure 9.8). The height should be adjustable to compensate for the tidal and freeboard differences and to maintain a minimal constant dropping height, reducing any secondary breakage.

It should also be possible for the conveyor belt to swing in and out to distribute the material evenly over the full width of the barge or vessel, lengthwise distribution is achieved by shifting the barge or vessel. Otherwise, the vessel needs to trim (using water ballast) continuously during loading in order to keep an even keel. Moreover, high stockpiles can lead to segregation, with larger stones rolling to the bottom and the fines remaining on top.

The simplest solution will be to use a conveyor belt loaded from a hopper with a tray feeder system. The hopper can be loaded either by dump trucks when the hopper is large and travel distances from stockpiles are long, or by wheel loader when the hopper is relatively small and the driving distances are shorter, ie when the stockpile is close to the hopper. The material is released out of the hopper, then passes via the tray feeder on to the conveyor belt and into the vessel.

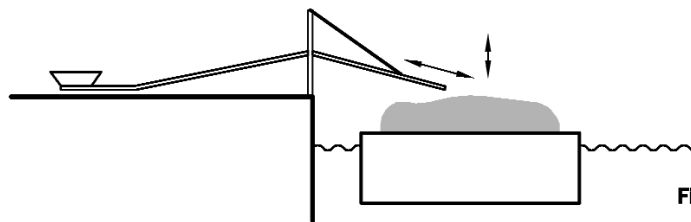

Figure 9.8
Conveyor belt system for loading

Loading by conveyor, especially in hot, dry conditions, is a very dusty operation. It may be necessary to take preventive measures, either by spraying with water to reduce the mobility of the dust or by using cascade bins (see Figure 9.9). Cascade bins will prevent the dust escaping, but the system does demand extra personnel, as the level of the cascade bins has to be adjusted while the vessel is being loaded.

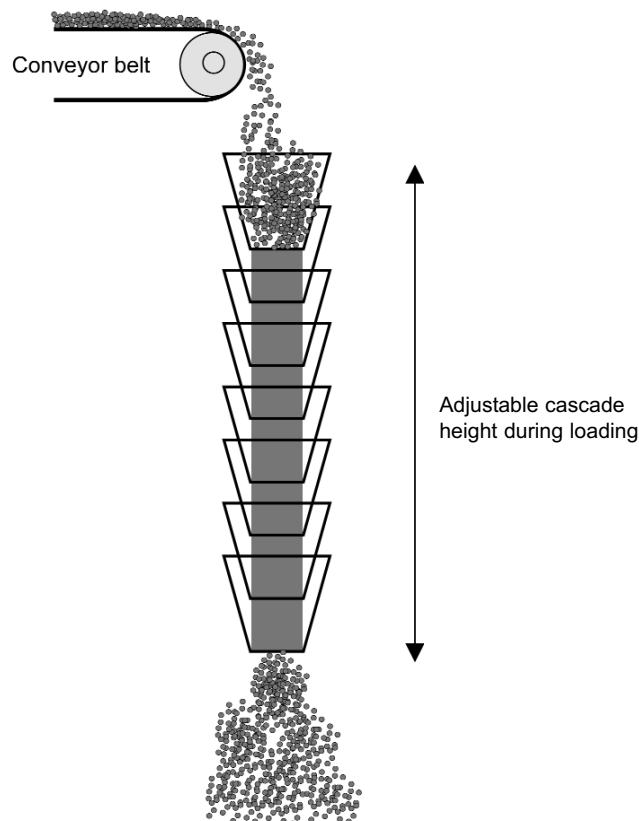

Figure 9.9
Cascade bins

9.2.2.2 Loading of coasters

Coasters can be used to transport coarse and light gradings and even heavy gradings, provided the bottom of the hold is covered with a layer of smaller material to protect it against damage from falling stones. This type of vessel is loaded by an excavator positioned on a gantry across the hold (see Figure 9.10). When the excavator is fitted with a grab, the materials can be tipped on to the quayside beside the vessel, from which position the material can be loaded by the grab. However, when the excavator is fitted with a bucket, the materials have to be tipped into a bin from which the excavator digs the materials to be loaded (see Figure 9.10). A coaster has a much higher sailing speed than tugged barges and is self-unloading, eliminating the need for additional unloading equipment at the point of arrival.

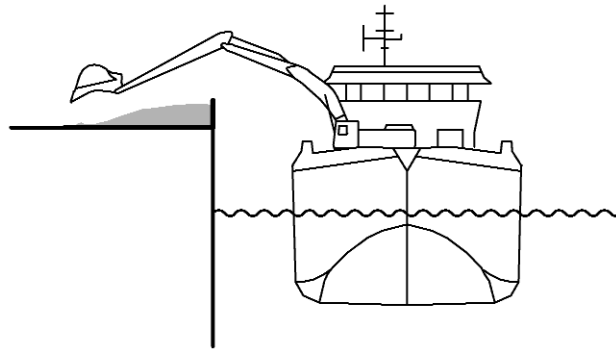

Figure 9.10
Loading a coaster

9.2.2.3 Loading of lorries and trains

The loading of lorries and trains differs from the loading of vessels as only small quantities can be loaded at any time. Planning the loading operation should take into account the type of vehicle involved (eg flat-bed truck, low-sided or high-sided wagon) and the material to be loaded (see also Sections 9.4.1 and 9.4.2). To verify that the right equipment is available and to ensure that any special loading requirements are costed, it is advisable to make early contact with the road or rail vehicle owner. The main issues are:

- loading area – should be firm and flat to allow vehicles on site
- access to loading areas – not all lorries have off-road capabilities, in particular lorries with trailers
- availability of steel-bodied lorries – if unavailable, make cost considerations for repair
- availability of suitable loading equipment, ie forks or grapples (see Section 9.3), and trained operators
- where heavy armourstone is to be loaded on flat-bed lorries, ability of driver to secure the load safely before moving off site
- availability of appropriate manpower and equipment at the quarry to load the stones – if not, further plant may need to be hire or acquired.

9.2.2.4 Additional considerations for unloading

Discharging of materials on site is likely to be carried out on temporary areas, but it is essential that the same guidelines regarding good practice employed in the loading operation are followed for discharging. In addition, because of the nature and location of rock structures (in particular sea defence work), several other factors need to be considered, including:

- protection of the workforce, plant and product from the effects of water action. Core materials and filter materials should be protected from loss during stormy or flooding conditions. For example this is often achieved by placing armourstone stockpiles seaward of the stocks of smaller materials

- segregation of the public from the stockpiling areas, using warning signs and, if possible, physical barriers to prevent the public, especially children, from climbing on to stockpiles
- clear marking of the stockpiles, even at high water, to prevent jet skis, windsurfers and small craft running into stocks submerged on the beach
- ensuring that personnel keep a safe distance from tipper trucks, which are dangerous when discharging, especially on uncertain underground formations
- preparation of clearly defined, considered statements for the discharge of materials at site, which should be disseminated to all site personnel. Non-essential personnel should be kept clear of the area during unloading
- rigorous implementation of local health and safety requirements
- action to prevent formation of soft areas in the foreshore or the riverbed as stockpiles are removed.

Specifics for unloading lorries and trains

The site should provide adequate and safe space for storage and for the manoeuvring lorries, the handling equipment and the possible simultaneous reloading of site vehicles. The handling equipment needed will depend on the road and railway wagons used, armourstone sizes, the available stockpile area and the equipment to be reloaded. In particular, large blocks require careful handling because of the risk of damage to site vehicles or temporary storage bins (for further details see Sections 9.4.1 and 9.4.2).

Specifics for unloading marine vessels

The discharge area needs to be clear of debris before the next delivery. The supplier of the marine vessel usually has individual requirements that need to be followed.

Temporary quays need to have adequate stockpiling areas to take the full load to be brought ashore (see Figure 9.11). The shore equipment required will be determined by the delivery method, space available and the delivery location. Often local ground conditions will determine the equipment to be used. The chief questions to be answered are whether the plant will be capable of tracking or running on the beach or foreshore and whether it can handle the quantities of armourstone in time to meet the delivery schedule. As each site will have different parameters, it is recommended that these points are discussed with potential plant and armourstone suppliers early in the tender process. The items below are important:

- before delivery it is essential that all permits, local agreements with fisheries, notices to mariners and environmental approvals are issued. Copies of these should be kept on the delivery vessel. These approvals should also be sought for transshipment zones and routes for transfer to the shore
- local coastguard agencies should be informed of the planned deliveries and agreed routes to and from the construction site
- marine deliveries should be supervised by an experienced marine superintendent or beach master, whose role will be to liaise between the site personnel and the master of the delivery vessels. He should be the sole point of contact with the vessel and should act as the eyes of the vessel's master to inspect the landing area for obstructions at low water
- clear markings for the unloading position should be arranged, with onshore transit points
- weather forecasts should be obtained for the area, updated every 24 hours
- any temporary moorings or other similar facilities should be organised and, where possible, tested
- where barges are to be beached it should be assumed that the beach conditions will change between deliveries. Where the sea bed cannot be seen, an acceptable method of verifying that the beach profile has not changed should be adopted. In all marine operations, the decision of the master of the vessel is final.



Figure 9.11 Unloading a sea transport barge (courtesy Royal Boskalis Westminster)

9.3 EQUIPMENT

9.3.1 General

This section provides a review of the types of equipment used for placing armourstone in rockfill structures and distinguishes **land-based** from **waterborne** operations. Included within **land-based operations** is the use of land-based equipment to place armourstone below the waterline. Some typical plant capacities are discussed along with related construction aspects.

An important factor governing the choice of equipment is the distinction between **direct dumping of bulk material**, for example in the core of a breakwater, and **controlled placement** of individual pieces of armourstone, such as in armour layers and underlayers of slope and/or bed protection works. Typically, controlled placement involves dumping of limited quantities per cycle or placement of individual stones.

Land-based operations

For land-based operations, dump trucks may be used for **direct dumping** of bulk material, if necessary in combination with bulldozers, wheel loaders, hydraulic excavators and wire-rope cranes. Hydraulic cranes and excavators can be used for **individual placement**, while wire-rope cranes are often used for concrete armour units.

Manufacturers of construction equipment maintain catalogues with full specifications for all their products. Many manufacturers also make this information available on the Internet. Some of the manufacturers of frequently used equipment, such as dump trucks, excavators, cranes, wheel loaders and bulldozers, are:

- Caterpillar <www.caterpillar.com>
- Daewoo <www.daewoo.com>
- Hitachi <www.hitachi-c-m.com>
- Komatsu <www.komatsu.com>
- Liebherr <www.liebherr.com>
- Link-Belt <www.linkbelt.com>
- Manitowoc <www.manitowoc.com>
- Volvo <www.volvo.com>.

For most projects, the client will commission contractors possessing specific machinery, some of which may have been modified to optimise performance of common tasks. General characteristics of these types of equipment are set out in Table 9.3, while specific information can be obtained from contractors engaged on site.

Waterborne operations

For waterborne operations, the following types of vessel are used for the **direct dumping** of bulk material:

- split-hopper barges and side stone-dumping vessels
- crane barges equipped with rock trays
- flat-top barges with wheel loader.

For **controlled placement** the following can be used:

- side stone-dumping vessels
- pontoons with hydraulic excavator or wire-rope crane
- flexible fall-pipe vessels
- trailing suction hopper dredgers, equipped to place gravel via a pipe.

9.3.2

Land-based equipment – dumping of material

Rockfill is placed by directly dumping (bulk) material using trucks or loaders, hydraulic excavators or wire-rope cranes. Table 9.3 lists some commonly used land-based equipment. The values of engine power, capacity, own mass and width are merely indicative and are approximate ranges for small to very large pieces of equipment. The type of equipment required depends on the size of the job and the working conditions on site.

Table 9.3 Overview of equipment types with the ranges for power, mass, capacity and width

Equipment	Engine power (hp*)	Own mass (t)	Capacity	Operating width (m)
Bulldozer	140–410	17–79		3.26–4.31
Excavator	140–515	22–85	1.2–4.6 m ³	2.80–3.50
Wheel loader	235–475	23–50	3.6–6.6 m ³	3.15–3.90
Articulated dump truck	280–415	23–35	23.6–38.1 t	2.90–3.45
Off-highway dump truck	485–730	24–76	39.3–66.5 t	5.00–5.10
Highway dump truck	225–375	12–20	12.5–25.0 t	2.55
Grab and wire-rope crane	150–375	50–160	65–325 tm	4.30–6.45
Lift/wire-rope crane	350–750	150–350	500–1500 tm	6.00–8.50

Note

* 1 hp = 0.746 kW.

Dump trucks

The simplest method of placement is to dump bulk material directly by highway or off-highway dump trucks, usually carrying loads varying between 20 t and 50 t (larger if quarry plant is available) and often with the assistance of a bulldozer to spread the dumped materials. These trucks require an access or haul road that is at least 4 m wide. The size of truck required depends on the armourstone grading. If there is only single-lane road access, regularly spaced passing places at least 7 m wide should be provided.

There are two types of dump truck: highway and off-highway. Off-highway dump trucks are suitable for driving with heavy loads, heavy armourstone and over rough terrain, eg on stones up to a size of about 300 kg. The trucks are subject to considerable wear when loaded with armourstone so they should have strengthened or protected bodies. Loaded off-highway dump trucks are not permitted on public roads because of damage caused by their high axle loads. Rubber and rubber-coated bodies for these vehicles are now available, the use of which reduce both wear and noise. Figure 9.12 illustrates a large articulated dump truck (ADT) with typical dimensions.

Both productivity and resistance to breakdown are improved by the provision of good-quality haul roads on site. This is especially important when highway vehicles need to deliver materials directly to the site.

Dump trucks are used to transport the armourstone from temporary stockpiles to the final placement position. In the UK, armourstone is often delivered to the beach at high water by barge or side stone-dumping vessel. At low water, the armourstone is recovered and loaded into the dump trucks for transport to the placement location.

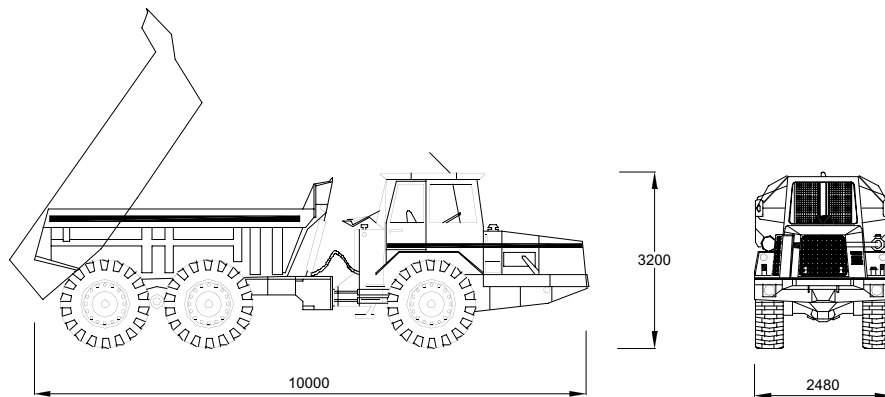

Figure 9.12 Large articulated dump truck, typical dimensions (mm)

Dump trucks are not designed to drive over armourstone; small material should therefore be used to blind off the armourstone. This blinding may need to be replenished at every tide and may be removed at the end of its use, to maintain the porosity of the core or underlayer.

Wheel loaders

Wheel loaders (see Figure 9.13) may be used when the armour stones can be obtained from a stockpile directly adjacent to the work site, such as in small breakwaters or for the construction of embankments and revetments. Compared with trucks, wheel loaders facilitate stone placing further out from the crest and in a more controlled manner.



Figure 9.13 Wheel loader working from beached barge (Royal Boskalis Westminster)

The use of wheel loaders to place stone in bulk is limited to gradings up to 300 kg, ie for the placement of core material, and in some cases for the secondary layers. Wheel loaders with buckets tend to scoop up surface material when digging into a stockpile, which may result in contamination. If the bucket is replaced with forks, larger stones can be handled individually without contamination.

Excavators

All excavators (see Figure 9.14) should have heavy-duty, waterproofed undercarriages, which will improve their life. Biodegradable oil should be used whenever possible in the hydraulic systems of excavators working in pollution-sensitive environments, so that problems do not arise if a hydraulic hose breaks. It is important that all the excavators carry oil spill kits to mitigate the effects of leaks of engine oil or diesel. Plant refuelling should take place in a compound away from the beach or riverbank that is equipped with bunded tanks and quick-release hoses. Long-reach equipment (see Figure 9.22) is often used to extend the period of tidal working, but this reduces the excavator's capacity, necessitating the use of larger machines.



Figure 9.14 Excavator working on the crest (courtesy J D Simm)

Table 9.4 relates the minimum excavator mass to the various stone gradings.

Table 9.4 Excavator mass in relation to stone mass

Armourstone grading	Excavator mass for handling (t)
Core material	15
1–3 t	20
3–6 t	30
6–10 t	45
10–15 t	60
15–20 t	70

Notes:

- 1 The tabulated data refer to operations with 360 degrees excavators on a horizontal floor, viz quarry handling; in such situations the tabulated gradings are valid for reaches up to 9 m.
- 2 When placing stones in rock structures, ie on slopes, the lifting capacity is substantially smaller than the above data and should be determined by using load charts according to the specifications of the manufacturer.

Hydraulic wire-rope or crawler cranes

Stone delivered by dump trucks or wheel loaders can also be placed by wire-rope cranes (see Figure 9.15). When placing bulk material these cranes can work with skips or rock trays that are filled at the quarry or stockpile and transported to the construction site by trucks, or trays loaded directly at the site. In these cases, heavy cranes are used, which require plenty of space. The production capacity of this type of crane is determined by the volume of armourstone that it can lift, its working radius and its rotation and lifting speed. Manufacturers provide tables and figures giving lifting capacities that depend on the boom length, boom angle and working radius. If armourstone material is tray-placed the ratio of container to payload is in the order of 1:2 to 1:6.



Figure 9.15 Crawler crane working on breakwater crest (courtesy Brien Wegner, USACE)

9.3.3 Land-based equipment – controlled placement

Controlled placement is defined here either as bulk armourstone placement in relatively small quantities per cycle or as the individual placement of heavier pieces of armourstone.

The equipment used for this type of armourstone placement is either a hydraulic excavator or a wire-rope crane (see Figure 9.14 for an example). For cyclic placement of relatively small quantities of armourstone, hydraulic excavators are more suitable because of their quick duty cycle. Excavators are often equipped with an orange-peel or open-tine grab (see Figure 9.17) to dig into the stock of core material dumped by trucks. Alternatively, a bucket or long-reach equipment can be used for this purpose. Wire-rope cranes are suitable for heavy stones and stones that require placing at a greater reach.

The options for the individual lifting of armourstone, sometimes provided with lifting aids, depend on the stone size itself and the handling required and include:

- grabs, chains or dogs
- chain slings
- wire-rope slings
- epoxy-grouted eyebolts or hooks.

The selected method should be assessed for safety. Such assessments usually give preference to the use of grabs and grouted hooks, which only partly depends on the contractor or the equipment he employs. Individual stones may be carried to the site on flat-bed lorries or by

barge. The smaller excavators require a work platform at least 4 m wide, the exact size being governed by the counterweight radius. Larger cranes require a platform up to 8.5 m wide. These are minimum operational widths and make no allowance for passing.

Figure 9.16 indicates the relationship between the excavator size needed to place a given average armourstone mass and the maximum reach for a given load and excavator size.

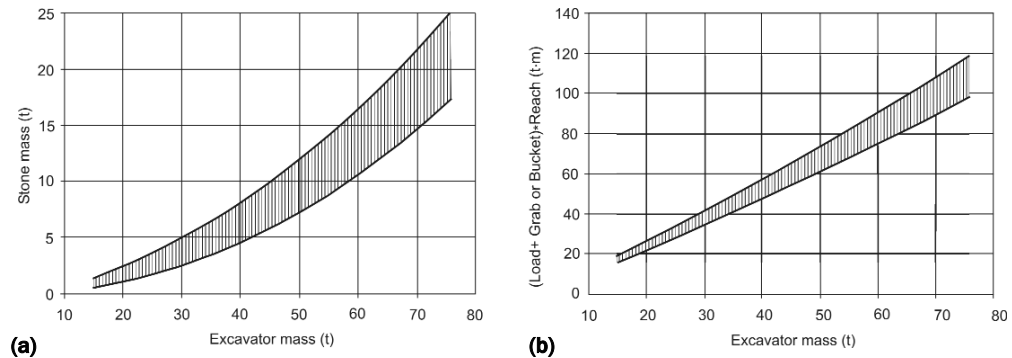

Figure 9.16 Indication of the relationship between stone mass, required excavator size and maximum reach

When fitted on to a hydraulic turntable, orange-peel or cactus grabs (see Figure 9.17a) provide the operator with considerable flexibility when placing armourstone to a desired position and orientation. A tight packing density is possible, which is important for amenity and safety reasons. A non-rotating grapple provides the operator with less control over the orientation of armourstone pieces than the powered orange-peel grab, but permits positive placing, including pushing and easy pick-up from a stockpile. Another type of grab commonly used is the three- or five-tine power fork (see Figure 9.17c) on a hydraulic excavator. Although rotating the individual pieces of armourstone is often impractical during placement, tight and rapid placement can be achieved because the armourstone can be pushed into place and does not have to be dropped from the vertical position, as is the case with the other grapples. A power fork can achieve denser placing than a grapple, which requires more space in which to open the tines. Note that where energy absorption is the prime requirement of the design, the armourstone needs to be placed as openly as possible. In this case, placement demands particular accuracy to achieve stability.

The available bucket mounted on a hydraulic excavator may be used on occasions, although this has the disadvantage that once stones have been placed they are difficult to move, making smooth profiling of the final surface and close or accurate packing harder to achieve. A normal bucket is well suited for levelling and profiling smaller materials, up to about 300 kg.

In all cases the quality of the resulting armour layer depends on the skill of the individual machine operator.

The production capacity of the excavators depends on the volume of the grab, rotation control and speed, and lifting speed. The volume of armourstone per cycle and the maximum mass of each individually placed stone depend on the size and reach of the excavator. The average speed of operation for a rope crane is lower than that for hydraulic excavators. However, in deep water conditions when placing toe armour at large radii it is often necessary to use a wire-rope crane to achieve the necessary reach.



(a) Cactus/orange-peel/closed-tine grab (often termed a grapple in scrap iron works)



(b) Open-tine grab



(c) Five-tine rock fork or power fork (also called a Bofors grab)

Figure 9.17 Examples of grabs used for armourstone placement (courtesy Royal Boskalis)

The mass, reach and hoist moment of hydraulic excavators and crawler cranes (also called wire-rope cranes) are interrelated. Table 9.5 highlights some of the indicative relationships.

Table 9.5 Indicative relationships between various machine characteristics

Characteristic	Unit	Relationship
Mass of hydraulic grapple	kg	$3.25 \times \text{grab volume (litres)} - 1910$
Mass of power fork	kg	$55 \times \text{excavator mass (tonnes)} + 200$
Mass of mechanically closed grapple	kg	$3.5 \times \text{grab volume (litres)}$
Mass of mechanically open grapple	kg	$2.5 \times \text{grab volume (litres)}$
Reach of hydraulic excavator	m	$5.8 + 0.06 \times \text{excavator mass (tonnes)}$
Hoist moment over front	tm	$1.6 \times \text{excavator mass (tonnes)} + 2.3$
Hoist moment over side	tm	$1.2 \times \text{excavator mass (tonnes)} - 7.6$
Reach of crawler cranes	m	$5.2 \times (\text{crane mass (tonnes)})^{0.4}$
Hoist moment of crawler crane	tm	$0.4 \times (\text{crane mass (tonnes)})^{1.31}$
Rope-operated grabs for crawler cranes:		
• closed-tine grab	t	$3.5 \times \text{grab volume (m}^3\text{)}$
• open-tine grab	t	$2.5 \times \text{grab volume (m}^3\text{)}$
Hydraulic grabs for hydraulic excavators:		
• closed-tine grab	t	$2.25 \times \text{grab volume (m}^3\text{)}$
• open-tine grab	t	$1.55 \times \text{grab volume (m}^3\text{)}$
• power fork	t	$0.06 \times \text{excavator mass (tonnes)}$

9.3.4 Waterborne equipment – dumping of bulk material

A successful dumping operation attains the design layer thickness, specified by a mean value and a minimum value, and an optimal rate of armourstone dumped, volume or tonnage per square metre. The dumping process, and consequently the result, are governed by the type of equipment used, water depth, current velocity and by stone characteristics such as density, grading, size and shape. Several types of self-unloading barges can be used, such as:

- split-hopper barges
- flat-top barges with wheel loader (see Figure 9.13 for an example)
- crane barges equipped with rock trays/skips
- side stone-dumping vessels or side-unloading barges (see Figures 9.19 and 9.20).

These types of vessel are usually employed to dump large quantities of bulk material for core construction, for example in breakwaters, sills or closure dams, where initially there is less need for accuracy of the levels. Figure 9.18 shows the use of a skip (or rock tray) for breakwater core construction.



Figure 9.18 Placing armourstone from floating barge using a rock tray/skip (courtesy CUR)

Split-hopper barges are towed or self-propelled, using special propellers for steering and propulsion. They operate by opening the bottom by splitting along the length of the keel. As soon as the opening of the barge exceeds a certain limit, the armourstone is rapidly dumped as a single mass. Dumping usually takes less than one minute. The mass of the material remains concentrated in a cloud, resulting in a fall velocity exceeding the equilibrium fall velocity (V_e) of each individual stone (see Section 9.3.6.2). As a result, the cloud of stones and water will reach the bed with a velocity two to three times V_e . In addition the stones can undergo a wide horizontal displacement after hitting the sea bed. The impact of this kind of dumping is very heavy and may result in damage when covering pipelines or cables, particularly in free spanning sections (see Section 6.4.2.4). When dumping gravel or coarse and light armourstone, a degree of controlled dumping may be necessary by blocking the opening mechanism at a certain reduced width.

NOTE: because of bridging effects in the armourstone mass and an irregular falling pattern, the opening should not be too small.

The use of these vessels is, in most cases, restricted to coarse and light armourstone to prevent bridging and damage to bottom seals during discharge. These vessels usually carry a maximum of around 900 t and need sufficient water depth beneath the keel to allow for the full cargo to be discharged without grounding.

For dumping from flat-top barges and side stone-dumping vessels the location and distribution of the dumped berm on the bottom can be effectively calculated (see Section 9.3.6.2), considering the gradation, water depth and current velocities.

Types of self-unloading barges used for direct dumping of bulk material are shown in Figure 9.19.

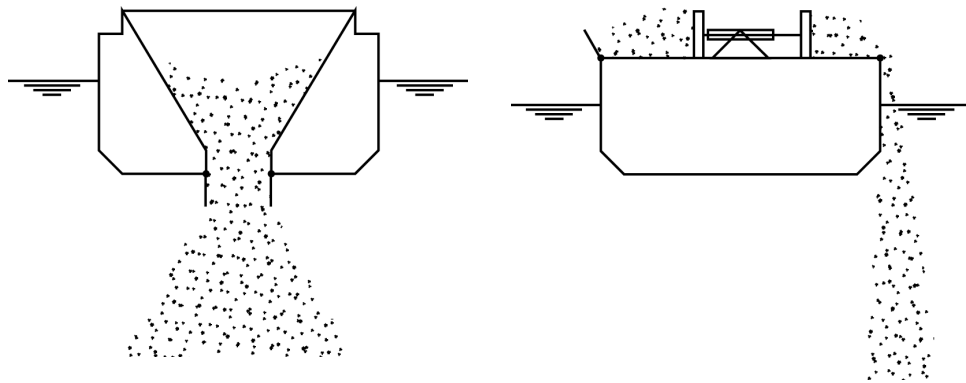

Figure 9.19 Types of self-unloading barge for direct dumping of bulk armourstone or core material

The mechanism of unloading from side-unloading barges is by sideways movement of the sliding shovels, as shown in Figure 9.20. This is an example of a side stone-dumping vessel. When working with a flat-top barge, the unloading is effected by the use of a wheel loader (or a bulldozer). The principle of unloading is the same for both types of barge.

9.3.5 Waterborne equipment – controlled placement

Side stone-dumping vessel or barge

An important feature of these barges is that relatively large quantities of armourstone can be dumped in a controlled manner. The armourstone is either gradually pushed off the loading deck by sliding shovels (see Figure 9.20) or transported and passed off the deck by chains or a vibrating-floor system. The speed at which the stones are pushed overboard is an important process parameter with respect to the quality, especially thickness of the dumping.

Depending on construction requirements, the armourstone can either be placed in layers of a prescribed mass per square metre, such as for bed protection works, or in relatively narrow ridges of a prescribed thickness, such as pipeline covers. In the first case, the vessel will be moved slowly in a lateral direction at a specified controlled speed, allowing placement in layers of the order of 0.3–0.5 m thick, on the sea bed or on the core. In the second case, the vessel remains stationary or slowly moves either forward or laterally, depending on the required dimensions of the structure and the local water depth. For this purpose these vessels are often equipped with special propellers for lateral control and a dynamic positioning system that is operated in combination with the moving velocity of the shovel blades. For a controlled discharge operation it is essential that the dumping rate, in kg/s or m³/s, is low and that each stone may be considered to fall individually (see Section 9.3.6.2). For a side stone-dumping vessel of 1000 t the dumping time is approximately 15 minutes.

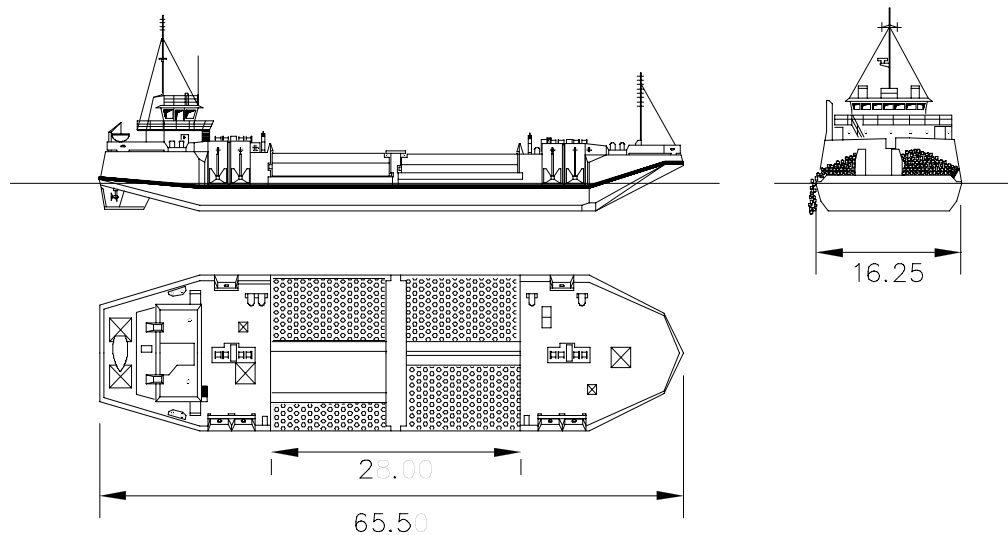

Figure 9.20 Plan views and cross-section of the 1000 t side stone-dumping vessel *Frans*; dimensions in metres (courtesy Van Oord)

The deck of this type of vessel is divided into sections that can be unloaded separately, permitting different types of armourstone to be placed from each section. This may be required when, to ensure the stability of the smaller armourstone in a strong current, a bottom layer of smaller stones has to be covered by bigger ones during the same dumping operation.

For loading capacity, a wide range of suitable vessels is available. The loading capacity varies from 500 t to 2000 t for larger vessels.

Large armour stones can be dumped by side stone-dumping vessels, even very close to existing structures, as shown in Figure 9.21.



Figure 9.21 Side stone-dumping vessel *Cetus* dumping 1–3 t armourstone near a jetty (courtesy Royal Boskalis Westminster)

Flat-top barges with wheel loader or excavator

These barges can be used to place relatively large quantities of stone to a reasonably high degree of accuracy. The barges are positioned by using a system of mooring wires and onboard winches. They may also be equipped with special propellers for lateral movement and with a dynamic positioning system. The advantage of flat-deck barges is that, compared with the types of barge described above, they require less specialised equipment (apart, possibly, from a dynamic positioning system) and for this reason they can be used in circumstances where specialised equipment is less readily available. This type of equipment can also place armourstone of different gradings during the same dumping operation. The capacity of these barges can be much higher, typically reaching 5000 t. Figure 9.22 shows the placement of reef armourstone with a long-reach excavator from a flat-top barge.

It is possible to use side-unloading barges or side stone-dumping vessels as described above for the construction of an armour layer of relatively small armourstones, for example in breakwaters or for slope protection works. The characteristics of the barge or vessel also depends on the sea conditions in which it has to operate.



Figure 9.22 *Placing armourstone with an excavator (courtesy Van Oord)*

Pontoon or vessel with a wire-rope crane

With this type of equipment small quantities of armourstone are placed at a time during each cycle and larger armourstone are placed individually. For example, bed protection works for bridge abutments should be placed in small quantities. Use of side stone-dumping vessels may be less preferable in these circumstances because:

- the area for manoeuvring is limited or
- the total quantities required are small, which makes the use of those vessels uneconomical.

This equipment can also be used for trimming the side slopes of breakwaters or embankments as an alternative to the operation of land-based equipment when the required reach is too large for that type of equipment. A barge-mounted crane may also be used to construct submerged dams, sills or bunds with a number of horizontal layers.

Cranes are also used when the accurate placement of individual stones is necessary – for example, when constructing a two-layer system in a breakwater, armourstone is positioned piece by piece. The crane operates from a barge and remains stationary on the site, using an anchoring system, while the armourstone is supplied by separate barges. However, materials supply and placement may also be combined in the same vessel, as shown in Figure 9.23.



Figure 9.23 Crane mounted on the rock supply vessel Jan Steen (courtesy Van Oord)

Fall-pipe vessels

This type of dumping system is employed to achieve greater accuracy in deeper water. Currently, controlled placement can be performed to depths of 1000 m. The system guides the armourstone down to a level several metres above the sea bed. Other advantages of the system are that currents do not influence the placing, segregation of the armourstone does not occur and work can be carried out at greater depths, from 20 m upwards, without losing accuracy.

Applications for which this type of vessel is commonly used include:

- pipeline protection
- seabed preparations (foundation structures)
- toe and slope protection.

The system consists of a vessel from which a flexible pipe can be lowered to several metres above the sea bed. The end of the pipe can be positioned by using an independent working propulsion unit. This propulsion unit can be provided with equipment capable of making pre- and post-dump surveys. Surveys can also be made from a separately working, free-moving remotely operating vehicle (ROV). The material to be dumped is fed into the fall-pipe tube by means of hoppers and conveyor belts. The construction of a cover layer on a submarine pipeline in water of considerable depth is a good example. The vessel moves along the pipeline at a constant speed while the armourstone is placed on top of the pipe. There are two systems.

- 1 **Semi-closed**, flexible fall-pipe system.
- 2 **Closed** fall-pipe system.

The **semi-closed** system (see Figure 9.24), consists of a cascade of individual, bottomless buckets connected to each other and lowered to a few metres above the sea bed. During the transport through the water from the surface down to the bed, dust and other fine material will be partially washed out, allowing a clear view and an undisturbed performance of survey equipment near the bed. This makes video recording possible during the dumping operation. A ROV mounted on the lower end of the fall-pipe can be equipped with monitor and surveying equipment. Propulsion power on the ROV is required to position the lower end of the fall pipe.

Another consequence of using a semi-closed system is that surrounding sea water is sucked into the pipe over its entire length, reducing the under pressure in the pipe and the fall velocity of the stones, compared with that of a closed pipe. However, the fall velocity will still be higher than that of individually dropped stones.

The size of the material used is limited by the diameter of the pipe. In general the maximum particle size (D_{100}) should not be larger than one-third of the smallest bucket diameter. For a pipe diameter of 0.80 m, the maximum particle size that can be dumped is about 250 mm.

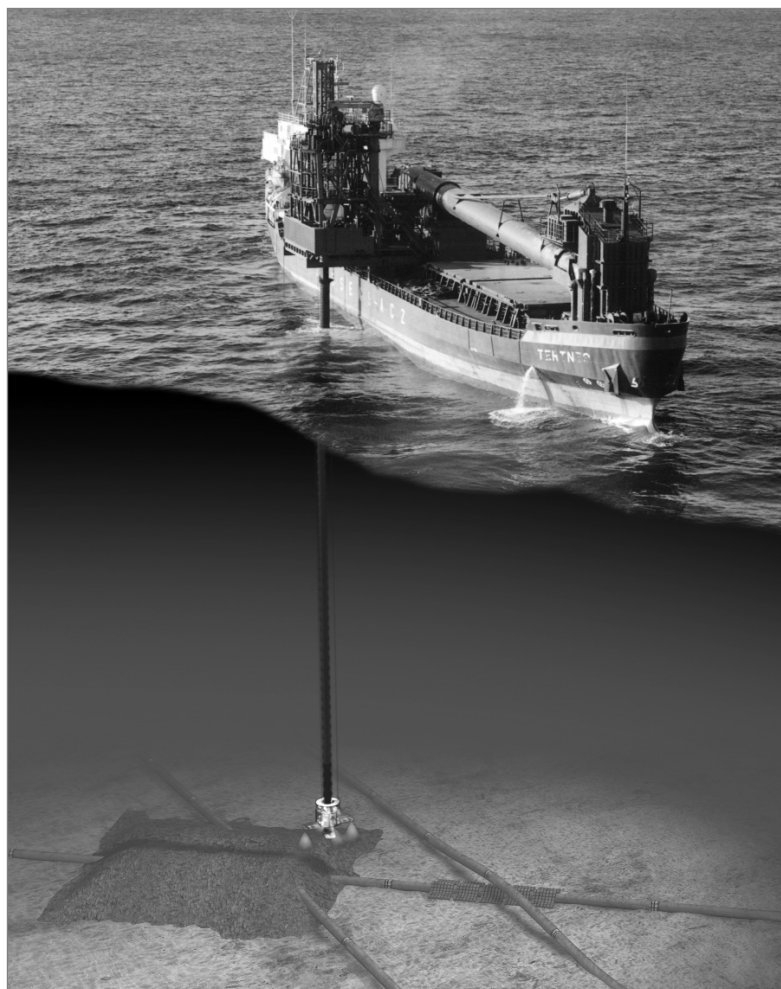

Figure 9.24 Dynamically positioned, flexible fall-pipe vessel (courtesy Van Oord)

In the **closed system** the fall-pipe is a continuous, closed pipe. In its simplest form the pipe is lowered from a spudded pontoon (see Figure 9.25). After a predetermined amount of stones has been dropped, the pontoon is moved a fixed distance and a new heap of materials is placed on the sea bed. The system is relatively simple and economical to set up. The sequence is similar to the dumping of material by grab crane on a grid system, but the accuracy is much higher. Depending on the control of the pipe, the positioning of the pontoon and of the pipe on location, which is affected by sea conditions, and the correct quantities of materials fed, the vertical accuracy can be in the order of 0.1 m for coarse gradings and $0.5 D_{n50}$ for light gradings.

An advanced system has constant-tension winches to control the position of the pontoon and uses a dynamic tracking system, a conveyor-belt feed system to control the amount of material entering the pipe and a hydraulic cylinder in the hoisting wire to control the level of the pipe. Additionally, the end of the pipe is fitted with a screed plate, which levels the materials placed by the pipe. This placing method is also called *scraging*.

On a spudded pontoon the vertical movement of the pipe can be monitored continuously with the aid of a rotating laser and compensated by the hydraulic cylinder in the hoist wire. This cylinder will also act as a swell compensator, making work in rougher sea conditions possible, with the above-mentioned accuracies usually achievable in swells of up to 1.5 m. The highest accuracy is achieved with the entire pipe system mounted on rails and travelling along the side of the pontoon (see Figure 9.25). This system can be used to make bed preparations for caissons or tunnel elements possible with a tolerance of a few centimetres.

The size of material that can be placed when using a closed fall pipe is determined by the diameter of the pipe. The EUL value of the grading placed should not be more than one-third of the inner diameter of the pipe. As an example, for 10–60 kg grading with M_{50} is 33 kg and an EUL value of M_{97} is 120 kg gives an extreme upper limit of $D_{n97} \cong 350$ mm (see also Section 3.4.3), and an inner pipe diameter of about 1100 mm should then be available.



Figure 9.25 Multi-purpose pontoon Scradeway with scrapper installation (courtesy Royal Boskalis Westminster)

Reverse operating hopper dredge

Gravel-sized gradings can be placed by using modern trailing suction hopper dredgers. Such hoppers can be equipped with systems to pump the mixture from the hold back through the suction pipe, with the draghead suspended only a few metres above the sea bed.

9.3.6 Working conditions

9.3.6.1 Working conditions for land-based operations

Direct dumping can be used to achieve steep natural slopes of about 1:1.3, the approximate angle of repose. This is important when dump trucks, wheel loaders or skips are used. As a result, the outer slope will have an irregular finish. The influence of wave action may give the slope a dynamic profile, and direct dumping is only carried out in core constructions of breakwaters or bunds enclosing a sandfill area, which may be trimmed at a later stage or covered by other layers. This trimming can be done by hydraulic backhoe excavators, provided the slope is not too long and the armourstone average mass is not too large (eg not more than 2 t). A dragline may be used for trimming for longer reaches. Figure 9.26 presents the reach of a typical hydraulic excavator (80 t) used for trimming. When trimming

is carried out in combination with direct placement by trucks, sufficient space should be provided to allow these trucks to pass the hydraulic excavator in operation. For direct dumping outside the natural slopes, it may be necessary to use excavators with a long reach.

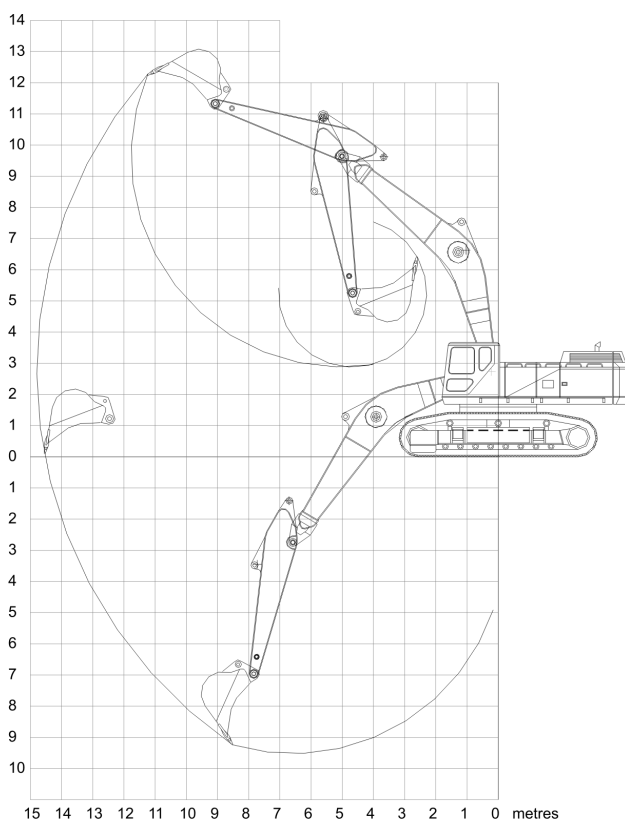

Figure 9.26

Typical reach for slope trimming (CAT 375L, 80 t excavator)

Direct dumping of wide gradings can lead to segregation problems. Larger stones tend to roll down the slope leaving the smaller fractions on top, which can result in a poor filter on the sea bed. This segregation is less of a problem when large volumes of armourstone are required, ie the core of a breakwater, armourstone quays supporting a seawall structure etc.

Accurate direct placement is achieved by means of wire-rope cranes or excavators with rock trays or skips that can place the stone directly at the required location and machines using grabs. Placement of armourstone in this way is often controlled by using a grid system. With modern computer-aided placement systems the design drawings can be transformed automatically into co-ordinates for the operator, indicating at which location specific profiles are to be constructed.

Operational site conditions

For operations involving the use of dump trucks, the elevation of working area and haul road is important. To avoid problems caused by possible wave-induced splash and spray, this elevation should be at least above the high water level. Only if the tracking area is well protected can a smaller freeboard be applied. In tidal regions the working level for the dump trucks and the crane should be determined by the spring tidal levels, while for stone placement the working times usually coincide with low water so as to accomplish an appropriate build-up of the side slope (this allows the operator to see what he is doing).

9.3.6.2 Working conditions for waterborne operations

For all waterborne operations, site conditions strongly influence planning. A distinction has to be made between site conditions affecting the operations and those that have a direct bearing on the armourstone placing process.

WARNING: Where a vessel is concerned, the captain has the final decision on whether particular operations can be performed under the prevailing environmental conditions.

(a) Operational site conditions

For waterborne operations the following site conditions are applicable:

- current, wave and wind conditions
- available water depth and manoeuvring space
- seasonal influences.
- **Current, waves and wind conditions**

Dumping should preferably be carried out around slack water. Positioning is achieved either by a roundabout anchoring system, usually six anchors, a combination of two anchors and two lateral thruster propulsion units, or a dynamic positioning system using a computerised thruster propulsion system. Operations sometimes necessitate material being dumped in areas affected by currents. When dumping in a current, in addition to displacement and spreading in the direction of the current, a significant amount of segregation should also be expected.

An impression of the forces exerted on a vessel or barge exposed to currents (with a velocity, U (m/s)) can be obtained by calculating the current pressure force, F (N), and the skin friction force, T (N), along an exposed surface with area, A (m²). The Equations 9.1 and 9.2 give the definitions of these forces, which are dependent upon the pressure, equal to $1/2\rho_w U^2$ (N/m²), and the exposed area, A (m²). From these forces the required anchor system can be derived.

$$F = \frac{1}{2} \rho_w U^2 \cdot A \cdot C_p \quad (9.1)$$

and

$$T = \frac{1}{2} \rho_w U^2 \cdot A \cdot C_f \quad (9.2)$$

where ρ_w is the mass density of the (sea) water and C_p and C_f are the pressure and friction coefficient respectively; common values are: $C_p = 0.8$ to 1.2 and $C_f = 0.04$ to 0.06 , both dependent upon the underwater shape of the vessel.

For common types of equipment, tidal currents should not exceed maximum values of 1.5–2.0 m/s without special precautions. The maximum is subject to the dimensions of the vessel or barge, on the anchorage possibilities, holding ground for the anchors and on the installed capacity of the propulsion system.

Downtime caused by waves and wind is determined by their influence on the positioning accuracy of the stone-dumping vessel and on the accuracy of armourstone placement rather than on the operational limitations of the equipment. Limiting conditions are discussed below in Section (b). In relatively shallow water, operations may be affected by shoaling waves.

- **Available water depth**

For the construction of structures up to a relatively shallow freeboard and for all types of barges and stone-dumping vessels, the maximum height for dumping material is governed by three criteria.

- 1 The **maximum draught** of vessels or barges, plus a safety clearance for heave or vertical motion. The highest practical level for this criterion is about 3 m below water level, although bottom-door barges require greater clearance because of the doors opening underneath. This draught restriction applies to shallow bed protection works, aprons for closure works, embankments etc.
- 2 The **loss of material**. Loss, especially of material during winter storms, should be limited to an acceptable level. For the core material, reshaping within the contours of the final core may however be acceptable.
- 3 **Manoeuvring space**. The available manoeuvring space and presence of structures may restrict the use of floating equipment.

- **Seasonal influences**

Construction may not be allowed during the winter season, the monsoon period, high river discharges or severe wave conditions, eg when loss of materials is unacceptable. If construction is extended over several seasons, temporary protection layers may have to be applied to prevent erosion during the intermediate closed season.

(b) Effect on stone placement

The objective of dumping is usually to place a specified amount of stone to achieve a specified profile in a prescribed position on the bed. The amount of stone can be specified as a mass (kg/m^2) or as a layer thickness (m). The accuracy of the dumping is expressed in terms of differences between the target and as-dumped profiles. In addition to the type of equipment (see Figure 9.27), the accuracy depends on:

- waves and wind
- water depth
- current velocities
- armourstone grading.

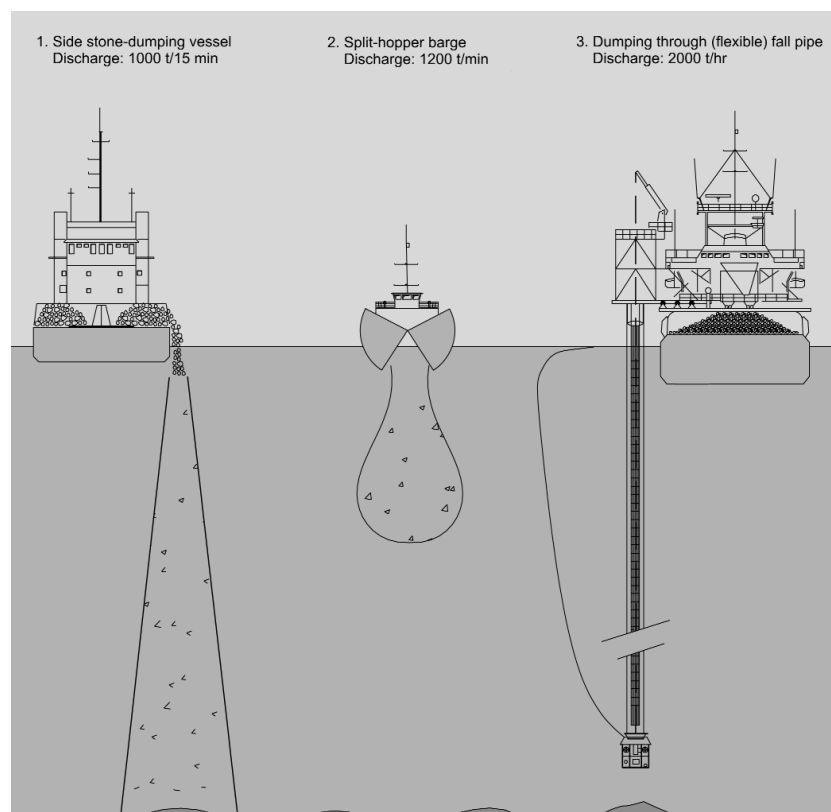

Figure 9.27 Placement of armourstone from different types of floating equipment

- **Waves and wind**

Locally generated short-period waves ($T = 2$ s to 6 s) and associated short wavelengths have less impact on the vessel or barge, and on the armourstone dumping process, than swell conditions characterised by long-period waves. Generally dumping is possible when wind waves do not exceed a height of $H_s = 1$ – 1.5 m, roughly corresponding with wind force six on the Beaufort scale, whereas under **swell conditions** wave heights beyond $H_s = 0.5$ m can impose restrictions on the dumping from vessels or barges, although dumping through a pipe is possible in swells up to 1.5 m.

When working with barge-mounted cranes, the maximum wave height is limited by the presence of the rigger mechanisms and derricks. Cranes are not usually designed to take any lateral forces such as swinging loads caused by barge motions and for this reason maximum allowable tilts should not exceed 5–10°.

Table 9.6 summarises limiting wave conditions for workability for various vessel types. A distinction is made between bulk dumping of materials, eg core, and controlled placement. Bulk dumping involves larger volumes of material and lower accuracy than controlled placement, which involves smaller volumes of rock or even individual stones.

Table 9.6 Summary of limiting wave conditions for various types of vessel

Type of vessel	Size	Size	H_s limit for dumping	H_s limit for placing
Large crane barge	60 × 20 m	150 t crane	0.80 m	0.60 m
Small crane barge	40 × 15 m	75 t crane	0.65 m	0.50 m
Large excavator on barge	35 × 12 m	70 t excavator	0.65 m	0.50 m
Side stone dumper	650 t		1.25 m	1.00 m
Side stone dumper	1400 t		1.50 m	1.25 m
Split hopper	800 t		1.50 m	N/A
Split hopper	2000 t		2.00 m	N/A
Flat-top barge and wheel loader	2000 t		0.80 m	N/A
Fall-pipe barge	50 × 17.5 m		N/A	0.65 m
Fall-pipe vessel	10 000 t		N/A	3.50 m

Notes

The values given above are only an indication and can be influenced by factors including:

- the wave period – this is an important factor; for short-period waves the acceptable significant wave height H_s can be higher than for long-period waves
- the position of the vessel – when the bow or stern is facing the waves the acceptable significant wave height H_s can be higher than when the side of the vessel is exposed to the waves
- the significant wave height – this can be higher when dumping or placing small materials; the chance of damage with larger armourstone is higher
- keeping rock barges alongside a crane barge in the above conditions might require constant tension winches.

- **Water depth**

The water depth is a major factor that affects the **spreading width**, y (m), of the armourstone mass on the sea bed (see Figure 9.28). The behaviour of the falling stones during the direct dumping process differs from that with controlled placement.

For **controlled dumping**, the fall velocity of individual stones (V_e) is a major process parameter, whereas for **direct dumping** the bulk of the falling stones will behave as a high-

density stone/water mixture ($\Delta_{sw} = 1.0\text{--}1.2$). The high fall velocity of this mix, which may exceed V_e , causes a hard impact on the sea bed. After hitting the bed, the material usually slides and is pushed away to the sides, leaving a minor quantity at the desired spot (see Figure 9.28b). It is inadvisable to use this dumping process for jobs requiring accurate placement of stone, such as the protection of pipelines or cables in deeper water. The use of split-hopper barges and other methods of direct dumping is limited to the dumping of large quantities of stones in shallow water, where accuracy is not a high priority.

More accurate placement can be achieved by **controlled dumping** from side-dumping vessels, cranes or fall-pipe systems. Here, the accuracy of the dumped layer thickness or height can be improved by dumping several thin layers of armourstone, in the order of 0.3–0.5 m, depending on the total required structure height and average size of armourstone. The stone will spread in directions parallel and perpendicular to the barge as a result of mutual interaction between the stones and the ambient water. After impact, the stones will spread farther along the bed. The extent of this spread depends on the method of dumping, the bed slope and the characteristics of the stones and the bed. An impression of the total dumped width, y , of stone placed from a side-dumping vessel as a function of water depth, h , has been obtained from model tests performed on construction of the bed protection for the Eastern Scheldt storm surge barrier in the Netherlands (Delft Hydraulics, 1989). Equation 9.3 gives the approximate relationship for this type of controlled dumping between the spreading width, y (m), and the water depth, h (m).

$$y = a\sqrt{h} \quad (9.3)$$

where $a = 1.9$ for quarried armourstone and $a = 2.1$ for rounded stone (approximate values).

NOTE: the value of y for direct dumping is considerably larger than for controlled dumping.

● Currents

For the displacement, x (m), of the centre of the armourstone mass relative to normal launching or discharge position, x_0 (m), the fall velocity of individual stones is the governing factor. This can be schematised in three stages: (i) falling through air, (ii) falling through water and (iii) hitting the bed. First (i), the stone, when dropped from a certain elevation, z (m), above the water, will accelerate from zero velocity to the fall velocity in air, V_{air} (m/s), according to Equation 9.4:

$$V_{air} = \sqrt{2gz} \quad (9.4)$$

Second (ii), after hitting the water surface, the velocity of the stone will either increase or decrease, from V_{air} to the equilibrium fall velocity in water, V_e (m/s) (see Section 6.4.2.4).

Finally (iii), the stone with nominal diameter, D_n (m), relative buoyant density, Δ (-), will hit the bed or the previously dumped stones with the equilibrium velocity in water, V_e (m/s), calculated with Equation 9.5:

$$V_e = \sqrt{\frac{4}{3C_D}} \cdot \sqrt{g\Delta D_n} \quad (9.5)$$

where C_D is the drag coefficient (-); values generally in the range 0.5–1.5, depending on the Reynolds number ($Re = V_e D_n / \nu$) and the armourstone shape.

Comparing Equations 9.4 and 9.5, and considering that $4/(3C_D)\Delta \cong 2$, it can be shown that the impact in water of a stone of a certain diameter can be compared with the impact of the same stone falling in air from a height of approximately its own diameter ($z = D$). When the impact associated with the fall velocity, V_e , is expected to cause unacceptable damage, eg to the falling stone itself or to anything lying on the bed, an alternative is to either place a cushion layer of small material or to place the larger stones near the bed by using a clamshell

or orange-peel grab, which is possible when small quantities of stone are required.

A major process parameter related to V_e is the displacement, x , of individual stones by the current and the resulting central displacement of dumped profile (see Figure 9.28). In a current with velocity, U (m/s), and water depth, h (m), acting on an individual stone with a diameter, D_n (m), and relative buoyant density, Δ (-), the resulting displacement, x (m), on the bed can be estimated from the falling time, h/V_e (s), with Equation 9.6:

$$x = C \frac{hU}{\sqrt{g\Delta D_n}} \quad (9.6)$$

where C is a coefficient, the value of which depends on the position of the vessel.

For dumping with cross-currents $C = C_{uc} = 0.86/\sqrt{\Delta}$ (-); common values for C_{uc} are 0.9 to 0.6 ($\Delta = 1$ and $\Delta = 2$ respectively). For dumping with a head-on current, a smaller value applies: $C = C_{ul} = 1/3 \cdot C_{uc}$. Referring to Equation 9.5, it should be noted that the coefficient C is equivalent to $1/2 \cdot \sqrt{3 C_D}$.

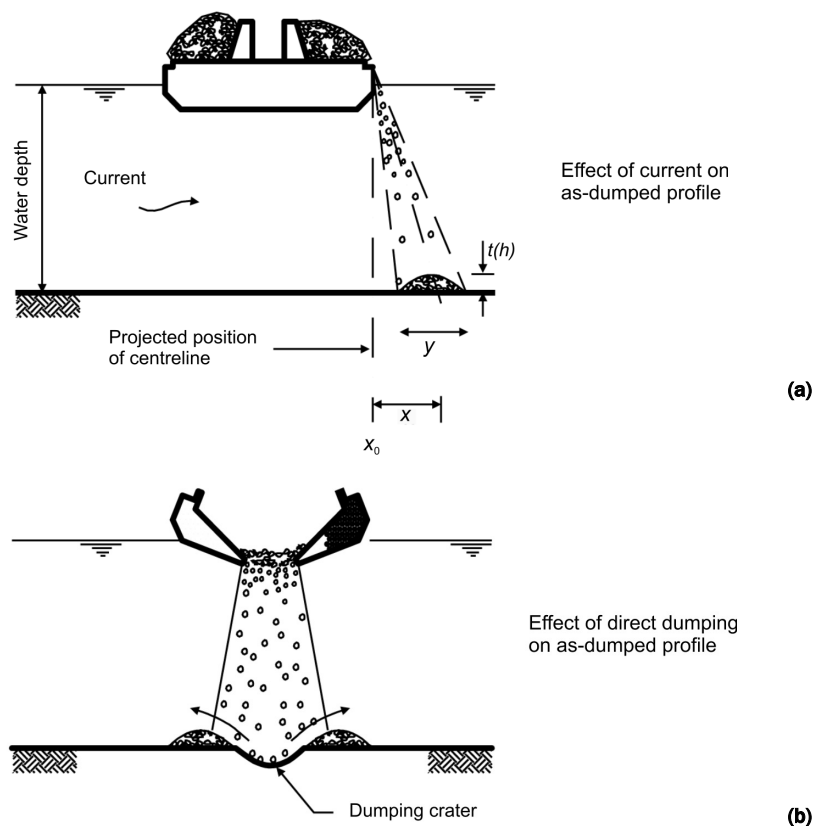

Figure 9.28 Control of dumping process

The final location and distribution of an armourstone grading dumped in a certain water depth with specified current velocity can also be computed, taking account of the physical interactions between the falling stones and the surrounding environmental conditions, including current, depth and density. Dumping accuracy in terms of height, width and location is dependent upon the water depth, the wave response of the vessel, the vertical current velocity profile, and the grading and specific density of the armourstone. Dumping a narrow grading in a water depth of 20 m and a current of 0.7 m/s results in the distribution shown in Figure 9.29a. Most of the stones are deposited about 10 m downstream of the dump location. When dumping heavier and wider grading in a depth of 20 m with a current of 0.7 m/s, the distribution results are illustrated in the pattern shown in Figure 9.29b. Here, the bulk of the material is deposited about 5 m from the dump location and segregation of the finest fraction is seen.

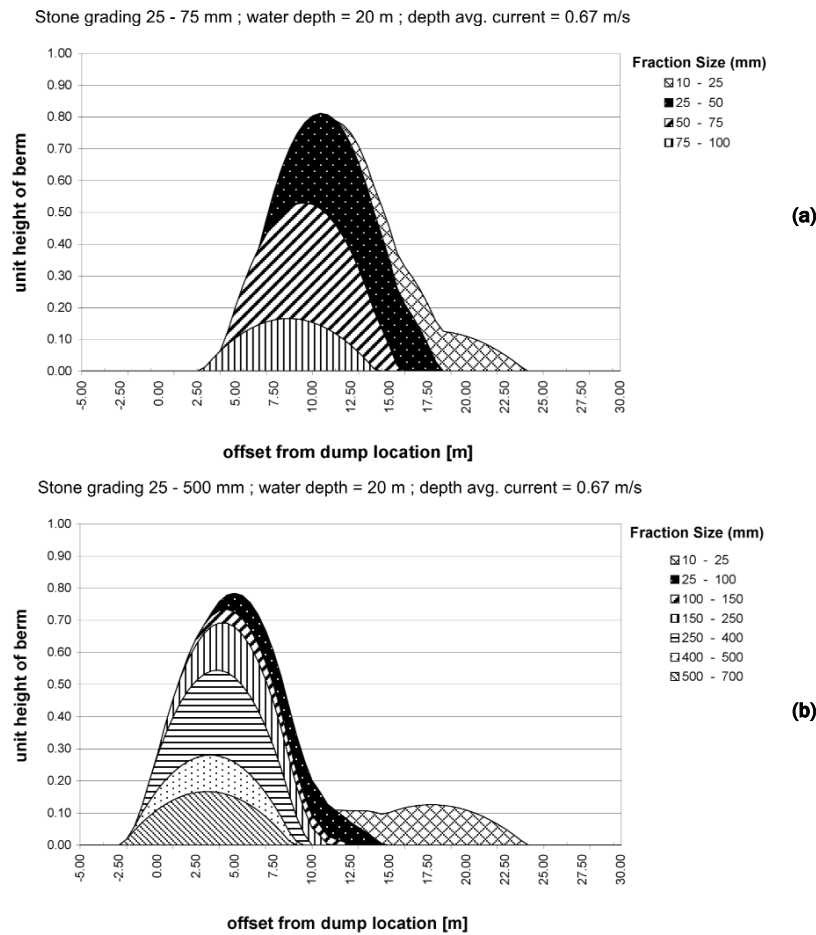

Figure 9.29 Computed distributions of dumped armourstone grading: (a) narrow grading, (b) wide grading

9.3.7 Tolerances

The term *tolerance* relates to the extent of deviation from the ideal that can be accepted or tolerated. Different definitions can be put forward based upon the following criteria.

- What is possible** Virtually anything is possible, but sometimes this can lead to great expense, take a long time and lead to the use of over-sophisticated methods.
- What is required** Since the technology exists to construct to very small tolerances, the specified requirements may reflect this and over-emphasise certain aspects of the works.
- What is necessary** Specified tolerances should reflect what is necessary for the structure to perform its designed function.
- What is affordable** The effect of tolerances on economic considerations can be profound. Often accepting a standard of finish that is functional rather than precise can lead to savings without which the construction may not be viable.

The setting of tolerances and the scale of deviations from the prescribed profile requires a careful balance of the above factors.

Tolerances for land-based operations

The acceptable tolerances for armourstone placement are determined primarily by the functional requirements of the structure so the strictness with which they are applied may vary. These requirements relate to:

- stability of the structure, eg currents and waves
- smoothness of the filter layer, eg foundations for caisson-type structures
- guaranteed navigation depth in the case of bed protection works
- visual aspects.

The construction method should be selected accordingly.

Example 1 For architectural reasons, rather strict accuracies of placement of the outer layer of a waterfront structure may be imposed, whereas the accuracy applied to the primary layer of a breakwater structure exposed to ocean swell will be dictated mainly by functional requirements.

Example 2 A gravel layer underneath a caisson requires strict accuracy, whereas underneath an underlayer or armour layer the average thickness is more important than the accuracy in relation to the required profile.

The tolerance that can be achieved depends primarily on the type of equipment and method of placing used, and on the size and shape of the armourstone (see Table 9.7). When using standard types of equipment, the following approximate tolerances apply in practice, using the nominal diameter D_{n50} .

Table 9.7 Practical, achievable vertical placing tolerances with land-based equipment

Depth of placing relative to LW	Bulk-placed armourstone		Armour layers and individually placed stones, with $M_{em} > 300$ kg	
	$M_{em} < 300$ kg	$M_{em} > 300$ kg (not armour layer)	Individual measurements	Design profile to actual mean profile
Above LW = dry	+0.2 m to -0.2 m	+0.4 m to -0.2 m	+/- $0.3D_{n50}$	+0.35 to $-0.25D_{n50}$
0 to -5 m	+0.5 m to -0.3 m	+0.8 m to -0.3 m	+/- $0.5D_{n50}$	+0.60 to $-0.40D_{n50}$
-5 to -15 m		+1.2 m to -0.4 m		
Below -15 m		+1.5 m to -0.5 m		

Notes

- 1 M_{em} = effective mean mass (see Section 3.4.3).
- 2 Tolerances apply even if the gradings being placed are not standard gradings.
- 3 All tolerances refer to the design profile and to the actual mean profile unless stated otherwise.
- 4 The tolerances on two consecutive mean actual profiles should be positive.
- 5 Notwithstanding any accumulation of positive tolerances on underlayers, the thickness of the layer should not be less than 80 per cent of the nominal thickness when calculated using mean actual profiles. Where an accumulation of positive tolerances arises and is acceptable to the designer, the position of the design profiles will need to be adjusted to suit.

In slope protection works, the cross-sectional tolerance is defined as the variation perpendicular to the designed slopes of the different layers.

Stricter tolerances than indicated in Table 9.7 – ie 0.10–0.15 m – can be achieved only with carefully selected stones, specific placement of the stones (see Section 9.8.1) or pitching and, for land-based operations, usually with manual assistance. This is applied when:

- high degrees of accuracy are required for aesthetic reasons or
- friction losses have to be minimised.

For slope protection and breakwater construction the average thickness of the armour layer, which is usually a double layer, is designed as $2k_l D_{n50}$, both below and above water. Typical values of the layer thickness coefficient, k_l , are given in Section 3.5.1 for different stone shapes and construction techniques. Some practical data are also provided in Section 9.8.1. Lower values of the layer thickness ($1.6D_{n50}$) have been achieved when pitching is carried out.

NOTE: a thickness of two armour stones would be equally acceptable as specification, despite the fact that a thickness of $2D_{n50}$ is traditionally the used value, ie without taking the k_r -value into account. In that case, there are some disadvantages associated with this slightly “over-specified” thickness, such as increased stability at the expense of increased run-up, toe scour and overtopping. The formulae used to calculate these hydraulic properties are largely based on model testing with two layers of armourstone, which rarely if ever reach $2D_{n50}$.

Tolerances for waterborne operations

As previously mentioned, the placing tolerance should be related to the functional requirements of the structure and the working method should be selected accordingly. The stricter the requirements, the more sophisticated the working method should be.

The measuring techniques play a role in defining achievable and acceptable tolerances particularly under water (see Section 9.9.9.2).

Although visual or aesthetic aspects are irrelevant in the case of underwater structures, smoothness may be important. For example, a navigational requirement may be that for the finishing of a bed protection that is stabilised by using a specified mass of armourstone (kg/m^2) individual stones should not protrude beyond the design level. Tolerances related to the layer thickness are important to ensure sufficient draught for vessels is provided. For filter requirements, a minimum layer thickness must be ensured (see Section 5.4).

When using the correct waterborne equipment, the vertical tolerances given in Table 9.7 for land-based operations should be possible. Vertical tolerances for the construction of profiles and layer thicknesses for core, underlayers, and armour layers using waterborne equipment are given in Table 9.8.

Table 9.8 Vertical placing tolerances that can be achieved in practice for work with waterborne equipment (CROW, 1999)

Grading	Side stone-dumping vessel and crane barge	
	Individual	Bulk
Coarse	N/A	+/- 0.20 m
Light	N/A	+/- $1D_{n50}$
Heavy:		
300–1000 kg	+/- $0.8D_{n50}$	+/- $1D_{n50}$
> 1000 kg	+/- $0.8D_{n50}$	N/A

Notes

- 1 The above values are indicative, up and down (+/-) and depend on the quality of the equipment, the skill of the operator and the circumstances, including swell, currents and steepness of a slope.
- 2 The values are the total of construction and measurement tolerances.

The horizontal accuracy of placement depends on:

- the type of equipment used, manoeuvring characteristics, presence of dynamic positioning system etc (see Figure 9.30)
- accuracy of positioning system
- external conditions such as waves, currents and water depth (see Figure 9.28).

In sheltered water, ie with no currents and waves, a horizontal accuracy of about 1 m can be achieved. In exposed conditions the accuracy will be lower and will decrease with increasing water depth (see Section 9.3.6.2 and Figure 9.28).

To reduce the probability of spots being left without, or with insufficient, armourstone cover, the flow of material leaving the vessel should be as continuous as possible and dumping in adjacent sections should either be overlapping or, when possible, be carried out in layers in a *stretching bond* fashion. Computer-assisted dumping or placing ensures that the theoretically required quantity is placed.

Other tolerances to be taken into consideration in the design are related to interface activities, ie where dredgers make the underwater sand slope or where dredgers dump the first layer of gravel. Achievable tolerances are:

- dredging by cutter dredger: 0–0.5 m vertical and horizontal
- dumping gravel by trailer dredger: vertical 0.5 m; horizontal 3.0 m
- levelling with the draghead of a trailer dredger: +/-0.2 m.

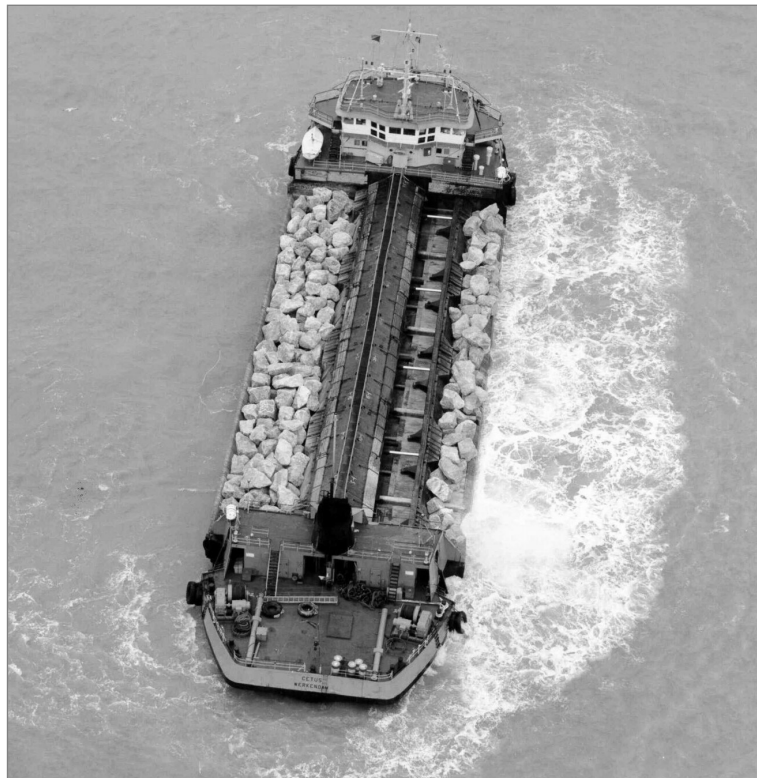

Figure 9.30 Dynamic positioning of side stone-dumping vessel *Cetus* with bow and stern thrusters (courtesy Royal Boskalis Westminster)

9.4 TRANSPORT

The transportation of materials used for coastal works is carried out by road, railway or water. Furthermore, each transport method can be subdivided into:

- one which merely delivers materials to a particular site
- one in which the means of transport is used as a method of construction.

Examples of these include: materials delivered to the site by rail, unloaded at the site and reloaded on to dump trucks for transport to the point of placing; marine deliveries, wherein materials are delivered to the vicinity of the site in a large-capacity transport vessel and then transhipped into smaller vessels that can move closer inshore and even assist with the placing of materials.

The choice of transport system is fundamental in planning the construction phase of the works, so the decision process should not be based solely on price, but should also consider factors such as:

- distance from the quarry source
- existing infrastructure at the site
- location and geography of the site
- preferred rate of delivery
- environmental constraints
- total quantity required and grading of stone
- availability of suitable means of transport
- timing or season (summer or winter) of the works.

Each factor should be considered carefully when a project is being planned if environmental, economic, health and safety aspects are to be optimised.

It is essential that whichever method of delivery is selected, all parties are aware of the requirements of armourstone delivery. Its abrasive nature, which can quickly destroy unsuitable equipment, can often catch out an unwary operator, so the selection process should carefully examine the track record of prospective transport companies and their contingency plans to deal with breakdowns and breakages.

9.4.1 Road transport

The following vehicle types are commonly used for the transport of quarried rock.

Flat-bed lorries

Flat-bed lorries only carry individual pieces of armourstone and tend to be used for blocks heavier than 3 t (see Figures 9.31 and 9.36). The maximum payload permitted on the lorry varies from country to country.



Figure 9.31

Flat bed lorry used to convey large armourstone during repair of Cherbourg breakwater (courtesy Service des Infrastructures de la Défense)

Unloading should be arranged at the delivery point and is carried out using a hydraulic excavator with a grab, or by a wheel loader with forks (see Figure 9.32). Flat-bed lorries are usually articulated trailers towed by tractor units, which may have difficulty accessing the site. Slings and chains can be used, but this is not a preferred option because of health and safety issues (trapping and possible unforeseen damage to equipment), and after risk assessment such methods will normally be discounted in favour of the others above (eg a wheel loader).



Figure 9.32

Flat bed lorry used to convey concrete armour units during the construction of Barcelona breakwater (courtesy CETE de Lyon)

Possible damage to the flat-beds must be considered; they should be carefully checked to ensure that individual stones are tied down so as to prevent their loss in transit and subsequent risks to the public.

Steel-bodied tipper and on/off-road dump trucks

These may be used for all materials, but the degree of care required depends on the size of blocks involved. A balance has to be made between the strength of the tipper body and its mass since payloads may be restricted owing to the mass of the body. Unloading is carried out by either tipping on to the stockpile or vessel (see Figure 9.33), or directly into the works (see Figure 9.34). Rigid vehicles with sub-frames may be used to haul filled rock trays. Particular care must be taken when tipping to ensure that the vehicle does not overturn.



Figure 9.33 *General view of Barcelona stockpile where trucks deliver stones to stocks or to a barge for onshore dumping (courtesy CETE de Lyon)*



Figure 9.34

Example of delivery trucks used to convey armourstone from the quarry directly to position on site (courtesy TPPL)

Despite all precautions, damage to the steel bodies is inevitable and regular maintenance is essential. The cost of damage is usually not included in the haulage rate or otherwise covered in the hire conditions, so the contractor has to pay for any damage.

Conventional aluminium alloy tippers

The majority of tippers used in Europe now have alloy bodies to optimise the net weight in the transport of non-abrasive bulk cargoes such as grain or aggregates. It is unlikely that material over 60 kg can be carried without damage to the tipper body of these vehicles.

The risk of damage to both steel and aluminium tippers can be minimised by using a backhoe excavator to load the armourstone. A wheel loader gives higher shock loads. To reduce the likelihood of damage to equipment it is essential to employ an experienced machine operator in loading this material.

On-site vehicles

These can be of any size and configuration, according to the relevant conditions. Modern preference is for articulated, all-wheel-drive dump trucks (AWDTs), usually with a capacity of 25–40 t. These provide fast transport of materials over rugged terrain and have proven extremely manoeuvrable in restricted site conditions (see Figure 9.35). They are also widely available and, to reduce downtime caused by damage, they often have tipper bodies plated with hardened steel. All-terrain all-wheel-drive vehicles should be considered, as they may be required to drive in locations with limited grip and traction.



Figure 9.35

Example of a dump truck transporting armourstone from temporary stockpile to breakwater section (courtesy Port of Le Havre)



Figure 9.36

Sling being placed on heavy armourstone before flat bed lorries leave the quarry (courtesy Carrières du Boulonnais)

9.4.2

Rail transport

Only the largest projects will justify the installation of a new railway siding for stone delivery. This form of transport can be attractive when a quarry is identified that has its own railhead, and where the project is able to make use of a nearby rail facility that is able to accommodate the discharge of trains.

The size of the unloading facility often dictates the length of train which can be used and thus the total amount of material that can be delivered at one time. The net weight to be loaded on to each railway wagon will depend on the local railway operator and infrastructure authority. Possible restrictions on the use of railway networks because of conflicts with the timing of passenger trains and other goods traffic should be investigated early in the planning process. In the UK, for example, goods trains are often only allowed to travel at night, when it may not be possible to unload at the railhead or work site.

The contractor should pay particular attention to the unloading requirements for railway wagons. These will depend on the siding layout, the types of wagon used, the size of the stones to be transported and the unloading equipment available. To minimise the risk of damage to wagons and to ensure the right equipment is present, the wagon operating company should be contacted at an early stage. Larger boulders are likely to necessitate the use of flat wagons or wagons with demountable sides.

Flat wagons

Flat wagons have been employed for the transport of individual stones. The use of low-sided vehicles or wagons specially designed for armourstone carrying eliminates the need for securing straps. Flat wagons are usually loaded and unloaded by grab (see Figure 9.37).

High-sided open wagons

The use of conventional high-sided open wagons (also known as box wagons) is usually restricted to armourstone up to 100 mm in size because of difficulties with unloading. Side- and bottom-discharge wagons are available, but, to prevent bottlenecks in unloading, the contractor should ensure sufficient plant and vehicles are on hand at the receiving end.



Figure 9.37

Loading of train at local terminal at the quarry (courtesy Carrières du Boulonnais)

Self-discharging trains

These trains have a built in conveyor system, capable of very rapid discharge. They are designed to handle aggregates, so are suitable for small armourstone.

9.4.3 Waterborne transport

Waterborne transport can often be utilised to bring in quarried materials to work sites. The main benefit of this method is that large quantities can be brought to the site relatively quickly and with little disruption to the local onshore environment. This section outlines the means of transport available and highlights the vital operation of bringing materials from deep-water transshipment zones to positions where they can be handled by construction equipment.

Inland waterways, such as rivers and canals, can be convenient for the transport of materials to the site from either inland or overseas quarries. Stone to protect the inland waterways themselves is a prime candidate for waterborne transport. The armourstone is commonly transported in conventional dry-bulk vessels and push-barges. Flat-top barges are seldom used.

The abrasive nature of armourstone means that all vessels should be designed specifically for the purpose. Such specialised plant is usually employed on projects throughout the year, so early in the planning process it is important to ensure it will be available at the required time.

Although adaptation and even the building of new vessels is an option for larger projects, the contractor needs to assess carefully the costs of mobilisation, preparation, insurance and repair for any vessel purchased or chartered directly, and to view these costs subjectively. It is advisable for the contractor to contact a specialist marine transport company with its own equipment and expertise that is prepared to include in the quoted delivery rate all risks until the armourstone is delivered. A cheaper alternative is to charter the vessels and services from the transport company, but this may leave all risks – including weather and possible damage to the vessel – with the contractor.

9.4.3.1 Marine transport

From quarry source to offshore close to the site, the armourstone is transported by sea on ships or flat-top barges. Common to each of these transport methods is the need to provide adequate side and deck protection to the vessels. Armourstone pieces stacked on the deck to a height of several metres can become dislodged during transit and may drop on to the deck, with the potential for serious damage, or shift, risking a capsized.

Flat-top barges

Barges of between 5000 and 20 000 DWT can transport large quantities of armourstone to a location offshore. They have a draught of up to 6.5 m fully laden – see Figure 9.38 for an example.

Discharge equipment can be stationed on the barge and can travel with it for use during loading and unloading, but it is advisable to transfer this equipment on board at the transshipment location. The discharging equipment should be an excavator with both bucket and grapple available and should be of an appropriate size to cope easily with the material being carried. There can be major difficulties if the machine breaks down at the discharge end. The machine's electrical systems are the greatest potential weakness and should be thoroughly sealed against salt air.



Figure 9.38 Flat-top barge carrying 20 000 t of armourstone (courtesy Stema Shipping (UK) Ltd)

Once the barge is safely anchored in the transshipment area the sea tug may depart, weather permitting, minimising the risk of demurrage. However, as a result of several incidents of a barge dragging its anchor, national regulations in many countries, eg the current UK Defra requirements, state that a suitable tug must be on station or locally available while the barge is at anchor.

Self-loading and self-discharging coasters

These are fitted with onboard discharge equipment in the form of a hydraulic excavator with adequate capacity to load and discharge armourstone (see Figure 9.39). Such excavators are often equipped with a range of handling equipment to suit material of all sizes and are often mounted on board the vessel in such a way that they can travel over the length of the hold. The use of this onboard equipment allows greater self sufficiency in loading and discharging ports, avoiding dependence on shore-based cranes and restricting loading operations to trained crew members who are familiar with the vessel.



Figure 9.39
Self-loading and discharging vessel MV Mari (courtesy Sillanpää)

Vessels between 1000 and 5500 DWT are available, but, as with flat-top barges, they need to be suitable for the intended purpose and have adequate deck and side protection. Although the vessels are smaller than the flat-top barges, they have a higher sailing speed, permitting quicker turnaround times. The loaded draught can be up to 7 m, dependent upon vessel size.

9.4.3.2 **Transshipment to the shore**

With a view to protecting local habitats and wildlife, vessels and nets, the choice of transshipment location is a detailed process involving construction and delivery teams as well as local environmental interests and fishermen.

Among other things this discussion will be based upon:

- required depths of water
- local fishing grounds
- suitability of seabed conditions for anchor holding
- navigation channels
- environmental features on the sea bed
- protection from weather and sea conditions
- leisure activities.

Rigorous conditions relating to seabed surveys, methods of transferring materials from vessel to vessel to avoid spillage, timing constraints and other matters are frequently imposed. These conditions are stipulated in the licences that the contractor or client must obtain before work can start. As this process can be lengthy it should be initiated at the earliest opportunity, allowing the necessary notices including the Notice to Mariners, informing all parties of what is to take place, to be issued and circulated.

Once the marine transport vessel has safely anchored offshore at the agreed location the material is transhipped on to a smaller, shallow-draught craft to be brought ashore (see Figure 9.40).



Figure 9.40 Offshore transshipment (courtesy Stema Shipping (UK) Ltd)

A range of specialised plant is available but this section concentrates on the most common equipment and the methods. The choice of equipment can play a large part in the overall construction planning, as the transport vessel can often be used to assist with the actual building of the works.

In areas where the tidal range is small or the foreshore is too steep to receive the material, it may be necessary to construct temporary moorings and jetties. Alternatively, material can be landed at nearby local harbours and transported to the site by road.

Split-hopper barges and bottom-dumping vessels

A description of these vessels is given in Section 9.3.4.

Side stone-dumping and geostationary vessels

A description of these vessels is given in Section 9.3.5.

Side-tipping stone-dumping vessels

These vessels employ special twin propulsion units and are fitted with large dump truck bodies along the length of the deck (see Figure 9.41). The vessel brings the armourstone to the agreed unloading location close to the foreshore where hydraulic rams tilt the individual truck bodies until the stones have been tipped. These vessels have a laden draught of around 2.20 m and are limited to about 500 t per load. They are not able to discharge with the same accuracy as the geo-stationary vessels, but they can carry larger stone sizes, up to 12 t, can discharge quickly and are ideally suited for breakwater and sea defence deliveries. During discharge these vessels are susceptible to sideways movement and the skill and experience of the crew is paramount to ensure accuracy.

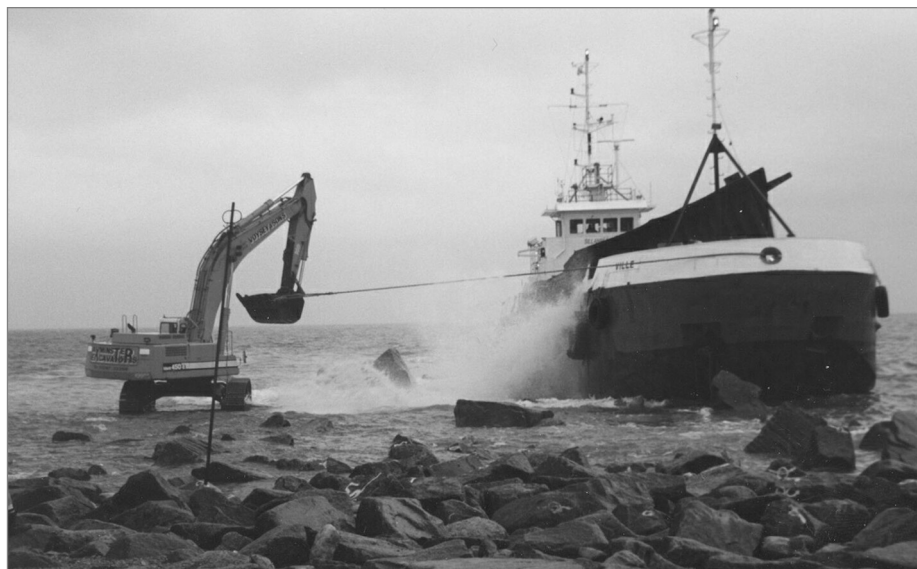

Figure 9.41 Side-tipping vessel *MV Ville* (courtesy Sillanpää)

Flat-top barges

The barges have no propulsion unit and are brought to the shore by an assisting tug. The barge may need to use shore wires or shore anchors to assist in the final approach to the beach and to keep it in position. When using shore wires, barges can discharge into the agreed location with a high degree of accuracy. Draught and trim depend on the size of the barge, the payload carried and the assisting vessel, and material is discharged either over the stern or over the side. Armourstone is discharged using an onboard loading shovel, there is

no limitation in the armourstone grading. The barges are ideally suited for breakwater and sea defence deliveries. Draught limits are often dependent on the tug used rather than the barge itself. Alternatively, if the foreshore is suitable, flat-top barges can be beached on the foreshore. This method will require careful beach preparation and inspection, ramps formed to provide access on to the deck of the barge and ballasting of the barge may be necessary to reduce buoyancy as the armourstone is removed.

9.5 CONSTRUCTION RISK AND SAFETY

9.5.1 Introduction

Coastal, maritime and estuarine construction is particularly hazardous because of the hostile and sometimes unpredictable nature of the environment. Research-based guidance documents by Simm and Cruickshank (1998) and Cruickshank and Cork (2005) have examined these issues for the coastal environment, and work by Morris and Simm (2000) has included them with respect to river and estuarine environments. The subject of risk management has received increased attention from industry, academia and government, as it can help to:

- identify and question the assumptions that affect the success of the project
- concentrate the effort into controlling the risk through risk prioritisation
- balance the costs and benefits of the risk controlling measures
- protect the health and safety of the operatives and the public.

Since 2000, guidance manuals have been prepared at the prompting of experienced marine contractors concerned about the reputation of the industry and aiming to promote good practice. Some of the topics discussed in the *Coastal engineering manual [CEM]* (USACE, 2003) include:

- uncertainty in environmental conditions and its influence on the risks associated with coastal and riverine projects
- how risk assessment and management throughout the project can help to mitigate the occurrence and consequences of these risks
- the influence of procurement process and insurance, as well as safety, time, cost and environmental objectives, on the procedures or protocol that should be adopted.

The following sections summarise the key risks and safety issues and potential mitigation measures. It is to be noted that fatal accidents are most likely to happen when the key hazards described below are occurring.

9.5.2 Key hazard sources and their delivery

The key sources of hazards are depicted in Figure 9.42. They derive from:

- an uncertain environment – wind, waves, currents, water levels
- the physical dynamic environment – the effects of the above together with poor ground conditions
- the users of the coastal or riverine environment – lack of containment of the site.

The above items influence the works, the choice of equipment, the disposition of operatives and the activities of the public.

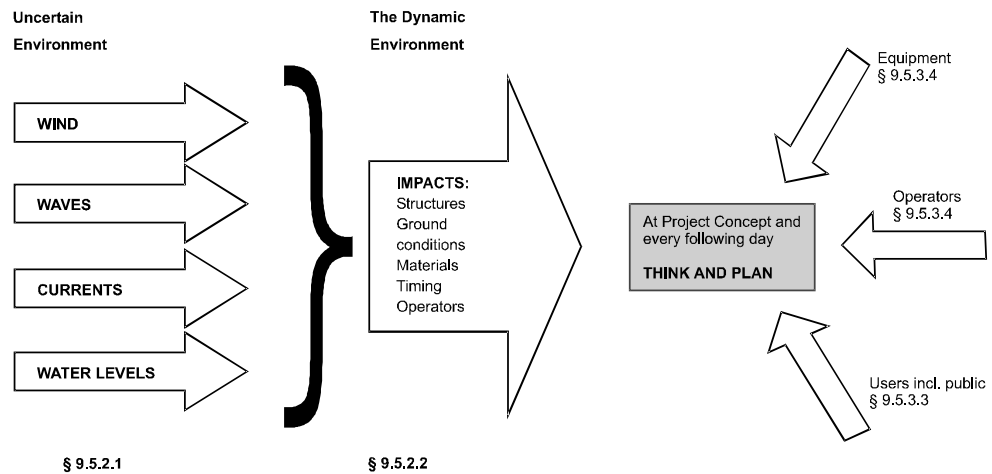

Figure 9.42 Key hazard sources in coastal engineering

9.5.2.1 The uncertain environment

The coastal and marine environments can be highly volatile and at times unpredictable, presenting a major challenge to those engaged in construction work. This section describes the basic parameters that can influence the planning and execution of construction works in such environments, namely:

- wind climate
- wave climate
- currents
- water levels
- a combination of the above probabilities.

These parameters are discussed briefly below. Further details are available in Section 4.2, as well as from Godfrey (1996), USACE (2003) and Simm and Cruickshank (1998).

Contractors need to be fully informed of the meteorological conditions on site. All design information should be passed on to the contractor at tender stage.

Wind climate

Apart from the influence that the wind climate can have on the wave climate, winds can also have an important effect on floating craft and on the operation of the contractors' plant. The effect of strong and rapidly varying wind speeds, along with local pressures, may cause significant motions of marine craft, with consequences for safety. In addition, wind may significantly affect lifting operations on shore, on floating crane barges and by cranes on jack-up platforms.

Wave climate

Waves can provide the single most important hydraulic parameter in coastal marine engineering construction. Technical terms defining wave conditions are described in Section 4.2.4.

The impact of waves on construction activities is wide-ranging and can:

- affect the delivery of materials to the site, eg preventing barges from leaving port, causing them to seek a harbour or other shelter, delaying them in transit, preventing them from unloading

- suspend progress of works until wave conditions reduce to workable values
- damage plant, through beaching, overturning or impacts on the works
- damage temporary works
- result in personal injuries to operatives through wave impact
- compromise effective rescue procedures
- damage completed parts of the works while permanent protection is not yet fully in place
- draw down beach levels, which can affect both the works and deliveries
- prevent access and egress to floating or offshore equipment.

The impact of waves is dependent on the constituent factors, principally wave height and wave period: long-period waves tend to cause more problems for vessel movements and greater overtopping and run-up. Other important factors include wave direction, storm duration, storm persistence and sequencing, and wave conditions from passing ships.

Tidal currents

Excluding circumstances where construction utilises caissons or pitching and driving piles in strong currents, the impact of currents on construction risk is limited particularly if currents are predictable, for example around the European coasts. In some cases, however, such as the Gulf of Khambat in India, currents can be strong and/or unpredictable because of the influence of surges. It is important to take this into account when considering submerged construction activities using remote-operated vehicles (ROVs) or divers. Currents can:

- affect the ability of a vessel to hold position offshore
- affect the ability of a vessel to approach the site safely, especially in restricted water depths
- affect rescue procedures and the ability of rescue craft to operate
- affect the ability to place materials within tolerance
- affect the ability to pitch piles and require immediate pile bracing after driving
- affect the incident wave conditions
- erode partially completed works
- apply loading on temporary works.

Water levels

Water levels may:

- define what works can be carried out in dry conditions and the access time available to those works
- prevent deliveries from reaching the site
- flood the works where excavations or cofferdams are used
- affect the wave and current climate that reaches the site
- affect groundwater levels and pore water pressures behind quays and retaining structures.

Sections 4.2.2 and 4.3.1 describe the components of water level that need to be considered. Often the major factor determining water level is the astronomical tide, which can be predicted accurately in advance. Meteorological effects can be predicted only to a limited degree, and then only a few days in advance and with a level of uncertainty. Seismic effects in general remain unpredictable although tsunamis can be predicted to a limited extent provided that the required technology is available and the source is very far away from the site. All these aspects should be considered, as they can pose a risk to the construction works.

9.5.2.2 *The dynamic physical environment*

The previous section discussed how uncertainties in the hydraulic environment can affect construction works. In addition, the hydraulic environment can interact with physical and other factors to affect the buildability of coastal works through:

- seabed changes
- changes in ground conditions
- changes in material quantities
- access and working space
- reliability of material supplies.

Any of these will affect the stability of partly completed, temporary and permanent works. Further details are given in Simm and Cruickshank (1998).

9.5.3 Principles of good practice for risk management

9.5.3.1 *Protecting the works*

Key features for protecting the works are summarised in this section, based on guidance in Simm and Cruickshank (1998).

a) **Stability of partly completed works and temporary works**

The daily conditions of wind, waves, tides and water levels that influence construction processes differ from the design conditions, the latter being mostly governed by extreme events. For the design of temporary works and for the assessment of the risk of damage to partly completed permanent works, the daily weather conditions are more important than extreme events. At sensitive stages, works can be susceptible to damage from quite mild wind, wave, water level and river flow conditions. The duration of these conditions can be critical. For example, a breakwater with only the core material placed may not be significantly damaged by a two-hour storm with an $H_s = 2$ m, but if that storm were to last for two days the damage could be serious. Given knowledge of these conditions, contractors can define the duration and sequencing of calmer periods and the work to be done then. For example, they may work in conditions of lower wave action or reduced river flow but be unable to proceed during stormier periods, when they may also need to protect the partly completed permanent works. Designers need to gather basic weather information and make it available, as it is impractical for contractors to obtain such data during a short tender period. To reduce the susceptibility to damage of the partly completed works, the designer should, where possible, consider the construction method when gathering the relevant weather data and designing the works.

b) **Methods of estimating site conditions for tender purposes, for real-time forecasting and site control during construction**

Reference is made to Sections 4.2 and 4.3 for detailed information on methods to estimate the conditions on site for coastal and inland areas respectively.

c) **Operational limits of plant**

The limits for plant operation depend on the type of plant used, local conditions and the skills of the operator. For example, the threshold conditions up to which a barge can successfully approach a temporary berth to unload are as dependent on the wave period, wind direction, currents, tide state and the skill of the beach master as on the actual wave height.

d) Temporary works and partly completed permanent works

Such works are often designed to, or assessed against, an arbitrary return period event, often 10 years, without regard to the probability of its occurrence during the construction period. The return period used in the design of temporary works or an assessment of the vulnerability of the structure should not be confused with the construction period. For example, if the return period of an extreme event is five years and the construction period is also five years then there is a probability of 67 per cent ($1 - (1 - 0.2)^5$) that this event will occur during the construction period (see also Table 2.4 in Section 2.3.3.2).

e) Seabed and riverbed changes

Unlike most civil engineering works, in hydraulic engineering the surface layers – ie the sea bed, river bed or beach profile – can be highly mobile, changing from day to day and season to season. These changes can be caused by natural effects, the presence of existing structures and by the presence of plant and temporary works, including partly completed permanent works and stockpiles. The changes may affect construction activity by altering:

- the intensity of wave action or flows immediately adjacent to the structure, which can affect the stability of the temporary works
- the draught available for floating plant at the works and for floating access
- the *dry time* available at the works and for land access to the works
- the accessibility to land-based plant of surfaces exposed at low tide conditions.

f) Timing of works

Tender documents issued by clients should have a specified contract duration, although an exact start date is rarely given. The requirement for three months' validity for tender reflects a corresponding uncertainty on the start date. As a result, the weather statistics during the contract may reflect a stormier or less stormy period than anticipated, especially if the contract is of only six to nine months' duration.

Where the client is uncertain of the start date because of lack of confidence in the availability and timing of funding, or for any other reason, it is advisable to specify a minimum 12-month duration of contract. In many cases, contracts can be combined or extended to stretch over a three- to five-year period, giving the contractor a choice over the precise period for carrying out the works and thereby reducing overall risk – bad weather restrictions in one year can be offset by better conditions in another.

Occasionally the contract is timed to run through the winter because of concerns about damaging trade or tourism in the summer months or to tie in with availability of plant and labour. Fixing the timing in this way automatically increases the hazards to construction and inevitable downtime. The associated incremental costs should be justified at the project appraisal stage (see Section 2.4) by appropriate incremental benefits.

g) Uncertainty about groundwater conditions

Monitoring groundwater levels requires proper understanding of the water pressures actually being measured, the strata in which they occur and the effect of this on soil strengths and imposed loading. Groundwater levels can be variable in the vicinity of rivers and estuaries and are closely related to sea or river water levels, even if the works are not inundated by tides or river floods. Problems that may arise when trying to dewater construction works include:

- unfeasibility of dewatering if the ground is too permeable, eg running sand in river situations and many situations in coastal engineering.

- drying out of a stream and/or downstream flooding when pumping for dewatering adjacent to the stream.

h) Variations in quarry geology

An unreliable armourstone supply can create a high risk of escalations in time and costs of construction. The key issue is the yield of the quarry (eg the percentage of armourstone above 1 t). Estimation and planning assume a certain yield value from the quarry (see Chapter 3). The designer may prepare this yield value if the tender time is short and also to ensure the same base of estimation for the competing tenderers.

Since the quarry's products form a major part of the project cost, any change in the assumed yield value has a major effect on that cost and on the completion time. To reduce this risk and even (in the case of an improvement of the quarry yield) make it beneficial to both client and contractor, a risk-sharing mechanism can be agreed that will share both additional costs and savings.

i) Other construction risk issues

- uncertainty of ground conditions
- achievement of construction tolerances – particularly when operating under water
- uncertainty of the condition of existing structures
- reliability of materials supply (see also Paragraph **h**) above)
- surface changes resulting from sediment transport, settlement and, for armourstone, the packing regime adopted
- availability and suitability of access to the works
- infilling of excavations and dispersal of spoil heaps by action of the water
- maintaining commercial or pleasure navigation
- vessel impact
- works causing adverse impact on surrounding environment
- effect of actions of pressure groups seeking compensation for, or cessation of, the works
- increased risks to safety through working in or over water (often avoidable by implementing basic mitigation measures)
- specific risks to safety, including working within cofferdams or within a pressurised environment such as caissons, use of different and floating plant, working with divers and the use or discovery of explosives
- environmental risks, such as surface water runoff and refuelling plant.

j) Risk management for cost and time control

Recent initiatives, including those described in Sections 2.3, 2.4 and 2.5, have endeavoured to formalise the risk management process for the convenience of engineers. The steps involved start with risk assessment procedures that mirror those required by law in the area of safety.

An excellent starting point is to use a risk workshop, the procedures for which are given in Simm and Cruickshank (1998) together with examples of workshop outputs. The brainstorming and prioritisation procedures enable systematic detection of risk issues and initial identification of risk mitigation measures.

Risk mitigation and/or control measures fall into one or more of the following categories of risk management:

- remove

- reduce
- transfer
- share
- insure
- accept.

Each of these options is discussed in Simm and Cruickshank (1998), with the optimum control strategy depending on the risk, the ability to manage it and the organisations involved.

Clients budgeting their works, and contractors looking to control their costs, should make estimates of any additional costs and/or time they may incur on coastal, river and estuary engineering construction projects that are attributable to risk factors. Many methods of estimating project budgets are available. The simplest involves preparing risk registers in which each risk is represented by a single probability and the cost of the consequences. More complex methods can extend this principle to a systematic description of all risks based on separate identifiable consequences: minimum, most likely, maximum. When the number and/or interaction between risk elements are such that a hand calculation would be difficult or time-consuming, use can be made of the Monte Carlo analysis technique for calculating a risk distribution from a given set of risk elements. See Vrijling (2001) and Schiereck (2001) for further guidance.

9.5.3.2 **Protecting the operative**

Health and safety provisions

In addition to the health and safety issues discussed in Section 2.6, a few typical items are discussed here. Coastal and fluvial construction sites are often situated in remote parts of the world where few welfare facilities exist. In such areas few or no records may be kept of lost time due to sickness and general poor health and absenteeism caused by unsociable hours and poor working conditions. It is therefore essential to decide how:

- best to provide basic welfare and cleaning facilities for the operatives
- to protect against disease and contamination risks, eg contaminated dredged material, Weil's disease
- tidal working or unsociable hours might affect operatives' health
- to manage overall site health and safety
- to ensure the safety of any operations by lone workers in remote areas
- to avoid fatigue and stress and to manage mitigation measures.

Specific health and safety provisions (Cruickshank and Cork, 2005)

- Platforms and gangways
- ladders
- site tidiness
- illumination
- weather conditions
- first aid equipment
- protective clothing and equipment including personal buoyancy equipment
- visibility of other personnel by operators of large equipment
- means of access: water transport
- access over partially completed structures

- rescue equipment
- lifebuoys and rescue lines
- grab lines
- inter-vessel and ship-to-shore transfer
- diving operations.

Delivering health and safety at the project planning stage

Health and safety should be considered at an early stage, as often the decisions made before the start of the formal design process have H&S consequences. By 2005 one marine consultant was including in all its reports a short section on the health and safety implications of choosing options from project inception through feasibility stages to detailed design. Simple risk assessment tables were incorporated where applicable, which enabled health and safety issues to be considered early on and provided a systematic way to record the decisions made.

Full and detailed risk assessments should be undertaken at later project stages (Simm and Cruickshank, 1998).

9.5.3.3 Protecting the public during construction

In the coastal and fluvial environment it can be difficult to separate the construction process from the public and other users such as fishermen. The high costs associated with coastal and fluvial defence projects are often only economically justifiable where significant assets are at risk, and those assets tend to be used by large numbers of people.

Key issues that raise hazard levels when working close to the public include:

- the difficulty of fencing off large areas of coast or riverbank during construction work; this particularly applies across beaches in the tidal zone
- the public are often attracted to coastal and fluvial areas in their own right and also to construction works, and they may not realise that the construction site is operational
- dog walkers often use the beach or riverbank in the early morning before safety personnel or security guards are monitoring the site
- a variety of users may be expected, from riders of quad bikes to kite flyers on beaches
- leisure boat users may be attracted to the construction works and not be aware of notices to mariners
- jet skiers and surfers in particular may try to get close to floating plant
- fishermen and anglers often operate outside daylight hours when the site may not be fully manned and they may not be fully aware of restrictions or notices to mariners.

Experience indicates that members of the public are less likely to pose a safety risk if they are thoroughly informed. The risks to public safety can be mitigated by hotlines, newsletters, newspaper articles and advertisements, notice-boards and by incorporating safe viewing stations. Other measures include organising school visits and consultation meetings and setting up project websites.

For many coastal or river engineering projects protecting the site boundaries can be difficult because of the dynamic environment. Consideration should nevertheless be given to using security fencing where practicable, perhaps targeted to protect active working areas and plant parking or maintenance areas, while also ensuring non-active areas are safe for public use. Employing security guards is another option.

9.5.3.4 **Selecting and using plant and equipment**

Plant used in coastal and river construction works falls into three categories:

- land-based plant, including earthmoving plant
- marine plant
- other specialist plant.

It should be recognised that much of the equipment used is not specifically designed to operate in a coastal or estuarial environment. Some equipment has been modified to help it meet these exceptional conditions, but when it is used in estuaries and along the coast it may nevertheless present greater risks than apply when it is being operated in its original design environment.

Risks can be reduced with care in selection and use of plant. Good control and co-ordination of marine plant in this hazardous environment is essential. While the use of some plant – eg jack-up and spud barges – can reduce one set of hazards, it may also introduce new ones, such as collapse of jack-up legs or wave slam under jacked up platforms.

9.5.3.5 **Summary of good practice**

New guidance manuals are available to help identify and manage construction risks in coastal, estuary and river engineering. This guidance is based on current good practice and includes the following recommendations:

- ensure that clients understand construction risks by participating in risk workshops and preparing cost and time risk registers as well as statutory safety assessments
- select optimum procurement routes and risk management strategies
- ensure that risk is managed by the organisation most capable of controlling it. Contractual arrangements should clearly define and allocate risks to those best able to manage them
- select and appoint consultants and contractors with appropriate experience to foresee, minimise and manage risks associated with the project, including foreseeable project variations or alternatives
- permit financial returns on work that allow time for risk management
- ensure robust methods of working that minimise risk and reward the acceptance of risk
- base the selection of most economically advantageous tender on probable out-turn cost as assessed using client's own risk cost model
- provide greater flexibility in the contract period to mitigate weather risk
- allow scope for alternative tenders and value engineering
- make reasonable provisions for weather and ground risks in the contract. Clients should provide all information available at time of tender, including detailed information on the duration and number of storms/floods and calms/dry periods. In particular:
 - *high wind, wave, water level and river flow events* should be clearly defined, probably in terms of a specified maximum event – for example a 10-year return period over a particular month of the year – to enable the contractor to price the project properly. Vague definitions such as “normal action of the sea” and “normal river flows” should be avoided in favour of precise formulations such as that adopted for compensation events under the engineering and construction contract
 - *ground condition risks* can be transferred to the contractor. However, it is advisable to reduce the risk to a manageable level by carrying out sufficient site investigation (see Section 4.4) early on in the project, when it can be cost-effective and timely and, if several projects are involved, allow achievement of economies of scale

- follow good risk management practice when adopting insurance as a risk transfer mechanism. Open discussions with insurers at an early stage to improve their confidence in the project. Better risk management will improve insurance results and bring down market premiums. For the individual contractor, it will ensure fewer incidents, reduce cost escalations and diminish the potential for penalties when delays occur. The insurer will gain confidence in the contractors' professionalism, and contractors will benefit from lower individual premiums.
- consider health and safety issues at an early stage and where possible remove the risks at source.

9.6 GROUND AND SOIL ISSUES

9.6.1 Ground conditions

For all work methods it is necessary to ascertain the stability of both the structure and the subsoil. This information is derived from a preliminary geotechnical soil investigation (see Section 4.4). Soft soil conditions can cause the structure to settle or may induce slip failures. Where this is likely, soil improvement should be applied, either by removing and replacing the soil or by vertical drainage. Sand that is loosely packed or susceptible to liquefaction may have to be compacted or removed. The possible need for these measures should be allowed for at the design stage. Geotechnical analysis methods are discussed in Section 5.4.

Even when soil improvement is not required or after it has been performed, the stability of the soil should be noted throughout the construction. Sufficient time should be allowed for the subsoil to settle during the construction of the different layers of the structure. Depending on the thickness of soft soil, this may take up to a year, in which case temporary protection against erosion should be installed. Alternatively, settlements can be allowed for by surcharging or overfilling to compensate. To prevent local instabilities – eg flow slides of susceptible layers in an embankment – sand should be placed in layers.

There are two types of settlement: short-term or primary, and long-term or secondary. Primary settlement may be alleviated by adding surcharge material, waiting for the settlement to stabilise over several months and then completing the structure to the final construction levels. One way to tackle secondary settlement, over a period of years, is to construct the whole structure with a certain overfill, so that the correct final levels are obtained after the settlement has stabilised. Both solutions should be agreed in writing by the designer and the contractor so that appropriate payment is made for materials. Where primary settlement is higher than expected, additional materials will be required.

9.6.2 Erosion and sedimentation

Core material and/or underlayers that are prone to erosion should be covered early to reduce to a minimum the losses caused by current and wave action. Based on the expected conditions during construction, the risk of such losses should be evaluated. In addition to this, from a morphological point of view, preference should be given to carrying out the construction by working downstream in order to reduce undesirable siltation in the work area prior to stone dumping.

Soil erosion may occur during construction because of flow contraction around progressing structures such as breakwaters, groynes, closure dams and bridge abutments. Both the designer and the contractor should be aware of the consequences this erosion has on material quantities. For this reason it is advisable to install a bottom protection – with waterborne equipment if necessary – before starting construction with land-based equipment.

9.7 WORK METHODS

This section discusses construction aspects for a number of hydraulic structures that involve the use of rock. First, the work methods and related construction issues for bed and bank protection works are analysed, as the construction of most structures starts with these parts. The equipment used for the hydraulic rock structures, the working conditions and the tolerances for this equipment are described in Sections 9.3.1–9.3.7.

The focus of this section is on coastal works, mainly because of the varying and sometimes adverse environment, which can be affected by storms and extreme tidal conditions. Construction of rock structures in sheltered areas such as ports and inland waterways, such as rivers and canals, uses similar techniques. In even more protected areas, smaller equipment is utilised. Typical river works that require specific techniques are examined in Section 9.7.5.

9.7.1 Bed and bank protection works

9.7.1.1 Types and functions

Bed and bank protection works protect a bottom or shore against erosion by waves and/or currents. These may fulfil various functions:

- as a foundation layer for a structure
- to prevent scour near a structure
- to prevent erosion of a river bed
- to stabilise a closure gap.

Bed and bank protection works are generally composed of various layers: a top layer of relatively large stones to withstand the erosive action of waves and currents, placed over one or more filter layers. The gradation of these layers should be such that migration of material between layers – and eventually out of the structure – is prevented. These filter rule requirements are discussed in Section 5.4. These protection works may consist of:

- a granular top layer and multiple granular filter layers
- a granular top layer (possibly some filter layers, if the top layer is too coarse to place directly on the geotextile) and a geotextile. The geotextile performs the filter function of the finest filter layers on the bed and reduces the number of filter layers required
- a prefabricated filter mattress ballasted by a loose granular top layer
- a prefabricated filter mattress ballasted by fixed ballast such as concrete blocks
- a gabion mattress.

The construction aspects of these different types of protection are described in the following sections. Construction is performed by positioning and installing a geotextile or filter mattress on the bottom and dumping armourstone on top of it.

For most bed protection and for large bank protection works (ie those with a large horizontal distance between the shoreline and the toe of the slope) waterborne plant is used. However, if land-based equipment with sufficient reach is available, its use will be more economical.

For working conditions and tolerances see Sections 9.3.6 and 9.3.7. The tolerances for underwater construction are generally determined by:

- filter requirements sufficient layer thickness
- minimum segregation of armourstone in the subsequent layers
- stability requirements sufficient mass of the total armourstone layer
- navigation requirements navigation depth to be guaranteed.

The need for geotextiles in the marine environment should be carefully assessed during the design phase since it can be difficult to place and secure the material to an acceptable accuracy. The geotextile is lightweight (it floats), large and very difficult to control in moving water. Nevertheless, techniques have been developed to achieve placement and the designer should discuss placing methods with specialist contractors and geotextile manufacturers.

9.7.1.2

Bed protection works

Full granular bed protection

The layers are often constructed by controlled placing, for example by using a side stone-dumping vessel (see Section 9.3.5), although for river works or works within ports, placing can be done by land-based plant. During construction, segregation of the armourstone and discontinuities in the layer thickness should be prevented. This can be achieved by:

- moving the vessel over the section to be covered while uniformly dumping the stones
- constructing each layer from multiple thin layers to correct the discontinuities of the previous dump
- dumping from both sides of the vessel while moving the vessel sideways
- creating an overlap between the sections to be covered.

To ensure filter stability the thickness of the different granular layers should be above $2k_t D_{n50}$. In terms of construction the minimum layer thickness is typically 0.5 m. Smaller coarse grading can be placed by trailing suction hopper dredgers equipped with systems to pump a gravel-water mixture back through the suction pipe. After dumping, the layers can be levelled with the draghead, also known as a bed leveller.

Strong currents can lead to segregation of the falling stones, depending on the gradation and water depth. When current velocities exceed 0.5 m/s care must be taken to ensure a suitable layer is placed or to await calmer conditions before dumping. Such current velocities do not affect the positioning accuracy of the vessel, but they do affect the quality of the dumped layers. Wave action, on the other hand, evens out irregularities during stone dumping and can yield a good-quality stone layer. As wave action affects the positioning accuracy of the vessel, the operability of the vessel is the limiting criterion for wave action.

As the first layers on the bed will be fine, these should be placed only when there is little current and wave action. To avoid erosion of filter layers during construction, the first fine layers should be quickly covered by the coarser layer(s). This is carried out by using a side stone-dumper with compartments that can be loaded with different gradings for the subsequent layer(s) where floating plant is used.

Bed protection using geotextile covered by armourstone

The geotextiles are supplied in rolls. They may be sewn together into practical shapes that can be placed directly on to the bottom, creating sufficient overlap for continuous coverage and taking into account the possible settlement and deformation of the soil. Sufficient flat space on land should be available near the site to permit the geotextiles to be unrolled and sewn together.

The geotextile can be placed by unwinding it from a roll that is pulled over the bottom or by immersing a frame (or sinker beam) to which it is attached. The geotextile can be temporarily stabilised with stones or sandbags that are placed by divers, until the armourstone layers are dumped on top. This method can be used when wave and current action is limited and for small-scale projects. On larger-scale projects the textiles can be pre-weighted on a grid pattern over the fabric and re-rolled on to metal tubes with appropriate pull ropes and then unrolled on the sea bed.

When dumping the first layer of armourstone on top of the geotextile, care should be taken not to damage the geotextile. The performance of the filter function may be compromised if the geotextile is damaged during installation. The geotextile can be torn or punctured by the angular gravel of a drainage trench or if armourstone is dropped on to it.

Several laboratories have undertaken experimental programmes on real sites to evaluate the damage on geotextiles by dropped stones (Caquel *et al*, 1999; Chew *et al*, 1999). The results of these tests are summarised as follows:

- the drop energy of the block is an important parameter to assess damage
- the soil stiffness plays a major part in dissipating this energy by deforming; the soil stiffness should therefore be taken into account in the design phase
- the elongation at maximum strength is very important for soft soils as the geotextile must penetrate the soil with the stone without tearing. In the design phase the geotextile properties should be based on the expected soil conditions.

A standard grading that is often dumped directly on to geotextile is 10–60 kg. A non-standard grading, 1–10 kg (material from the quarry that otherwise would not be used for the project), is also used as first (protective) layer.

The 10–60 kg grading is only an indication, as the maximum allowable armourstone grading that can be dumped directly on the geotextile depends on:

- the characteristics of the geotextile
- the water depth
- the equipment used
- the base soil – surface soil stiffness, grain size distribution
- the stone shape
- the revetment structure – one or several granular underlayers.

By taking these parameters into consideration, armourstone of a few hundred kilogrammes may be dumped on to the geotextile. The mechanical properties of the geotextile (pyramid puncture resistance, elongation, tensile strength level) should then be designed accordingly. The designer may also choose to specify an armourstone drop test to carry out a site-specific performance test as part of the geotextile selection process (see also Appendix A1, Model construction specification).

In all cases, the revetment above the geotextile filter must be thick enough to prevent the geotextile being directly exposed to ultraviolet light.

Before placing the geotextile, the bed should be cleared of anything that may cause damage, such as stones and tree roots. The first layer placed on the geotextile needs to be sufficiently thick to keep the material on the bottom and to prevent damage during the dumping of the next, coarser, grading. Placement of subsequent layers can be performed as described above.

Bed protection using filter mattress covered by armourstone

A filter mattress consists of a geotextile connected to a grid of stiffeners. These stiffeners may be made of fascines (ie bundles of willow twigs, a typical in Dutch practice), synthetic materials or bamboo. They facilitate the transport of the mattress by increasing its buoyancy and by preventing it from folding. They also serve to stabilise the armourstone during ballasting, preventing the stones from rolling down the mattress to the bottom.

The mattresses are fabricated at a construction site, preferably near the project site and completely above water. The site should be clear of obstacles and on a slope no steeper than

1:3. When the geotextile has been unwound and sewn to the desired size of the mattress, the stiffeners are attached. The mattress is carefully removed from the construction site by pulling the geotextile, distributing the pulling forces uniformly by the use of a pulling beam.

The mattress is transported by means of a sinking beam or pontoon and is attached to the bollards of a pontoon by sinking ropes via a simple I-beam (see Figure 9.43). The forces on the fabric from currents may be some 30 per cent greater than with waves only (assuming typical wave heights of 0.5–0.8 m). Where land-based plant is used, the mattresses are placed by crane using a lifting frame (see Figure 9.51).

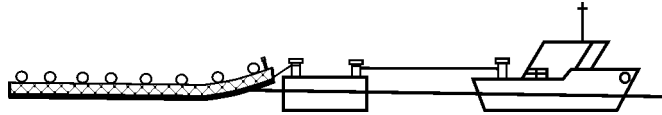

Figure 9.43 The use of a sinking beam for transport

After positioning, the mattress is sunk by dumping light armourstone on to it (using typically 1–10 kg or 5–40 kg). Damage to the geotextile should be prevented as above. In addition, protective mats can be sewn on to the fabric. Thereafter rockfill dumped on to the initial ballast material can consist of heavier armourstone of about 60–300 kg, depending on stability requirements and the filter rules.

To achieve an evenly spread armourstone load on a bed protection mattress a reliable plotting system or a floating framework should be used during sinking, and additional armourstone dumped by crane. Figure 9.44 shows the use of two pontoons to stabilise a mattress during sinking.

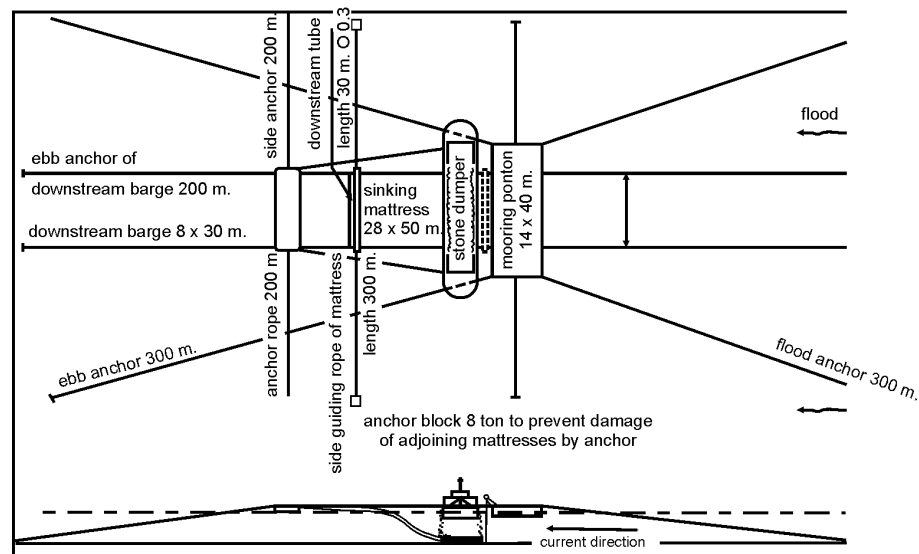

Figure 9.44 Sinking of a mattress with two pontoons typically in tidal areas

When a bed protection mattress is sunk, the loose fabric flaps are connected to the sinking beam at one end and to the tail beam at the other. To install the mattress at the required location, it is manoeuvred between the front and the tail pontoons, which need to have been accurately positioned in advance. After the sinking beam has been lowered, there is space for a stone-dumping vessel to move in. The front part of the mattress is kept in position on the bed by ballasting, after which the remaining part of the mattress is sunk. By controlled movement of the stone dumping vessel between the two pontoons, a uniform layer of stones can be placed on the mattress. The mattress should remain in the correct position and under tension by means of anchor winches from the tail pontoon (the downstream barge in Figure 9.44), thereby preventing the slope of the mattress from becoming too steep to retain the dumped stone.

An alternative sinking method is possible when the functions of the stone-dumping vessel and front pontoon are combined. The stone dumper is provided with winches, which can be used to lower the sinking beam of the mattress. After the beam has reached the bed, the stone-dumping vessel moves over the mattress. During this process the lines attached to the sinking beam may be adjusted. The tail pontoon keeps the mattress under tension (see Figure 9.45).

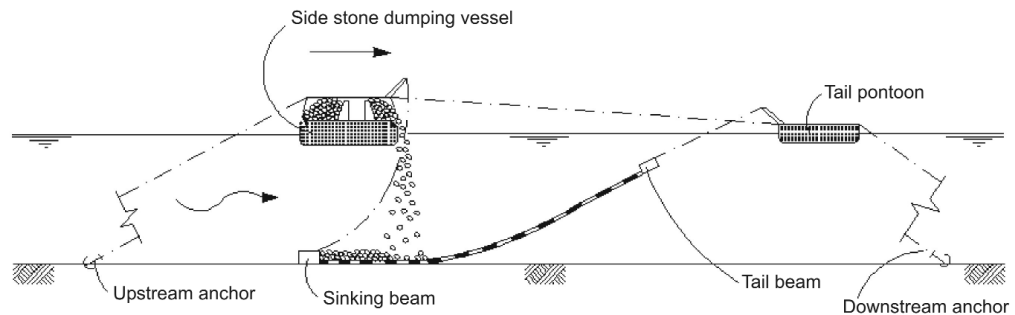

Figure 9.45 Sinking of a mattress with one pontoon (courtesy CUR/NGO)

After the mattress has been placed, additional armourstone is dumped by stone dumping vessels or floating cranes.

Instead of wooden stiffeners, occasionally a grid of reinforcement steel or scaffold poles is used, threaded through factory-fitted loops in the geotextile. The grid provides the stiffness required for handling and placing the mattress. As this mattress combination is not buoyant, it must be placed by a floating crane. This method is similar to the small-scale method described in the next section. Corrosion of the steel can damage the geotextile, so steel stiffeners are unsuitable for use in permanent structures where the geotextile must retain its filter function throughout the lifetime of the structure, but they may be quickly recovered by divers.

Bed protection using prefabricated mattress with fixed ballast

Prefabricated filter mattresses with fixed ballast are used as bed and bank protection and as covers for pipelines. The mattresses consist of geotextile with concrete blocks attached. During production, care should be taken to ensure a good quality of bond between the blocks and the geotextile. Another option is a geotextile mattress filled with sand as ballast.

For large-scale projects, the mattress can be rolled out on to the bottom from a pontoon, as shown in Figure 9.46. The pontoon is hauled while the cylinder is unwound. This method requires special equipment and is used when strict filter requirements must be met.

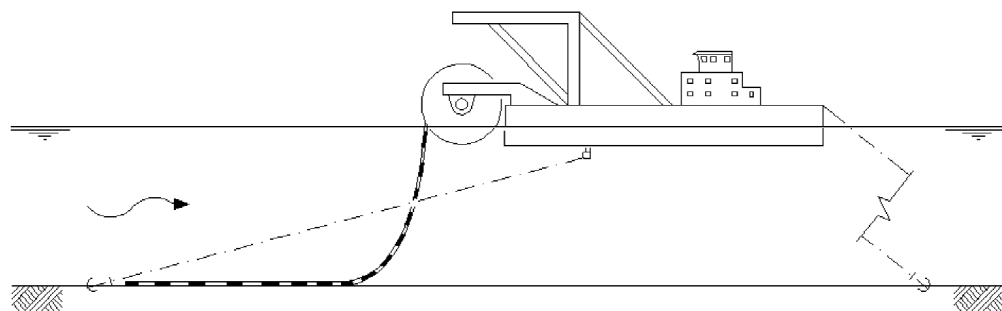

Figure 9.46 Unwinding a mattress from a pontoon (courtesy CUR/NGO)

Alternatively, rolls can be unwound on shore and weighted by evenly attached short lengths of rebar. The textile is then re-rolled on to a metal tube and the whole roll lowered to the sea

bed. Unrolling is achieved by pulling on ropes that are also rolled into the geotextile. The ends of the ropes are taken up to the surface to the barge, which unrolls them from the surface. This requires only the standard equipment shown in Figure 9.45.

When fixed ballast is used, extra ballasting after placement on the bottom may be unnecessary if the mattresses are stable under severe current conditions. When no stone layers are placed over the mattresses, the connection or overlap between the separate mattresses is important. Attention should be paid to the positioning of the pontoon. Usually no ballast is attached to a 1 m strip on the edge of the lowest mattress. This geotextile is stabilised flat on the bottom before the next mattress is placed on top, creating a sandtight joint between the two mattresses.

For small-scale projects, the mattresses can be placed by a floating crane equipped with special frames (see Figure 9.47). In these cases the maximum size of the mattresses is determined by the capacity of the crane and the deformations of the mattresses.

Where gabion mattresses are used, they may be filled *in situ*. Alternatively they may be placed as above except that the individual mattresses can be clipped together by proprietary fixings and so do not need to overlap. This method calls for a diver to be in continuous attendance to ensure close butting between units and to apply the clips. A geotextile can be built into a gabion mattress as part of the filling procedure. One advantage of this system is that completed units can be stacked, so filling operations can be carried out in a much smaller area, which can be remote from the placing site.

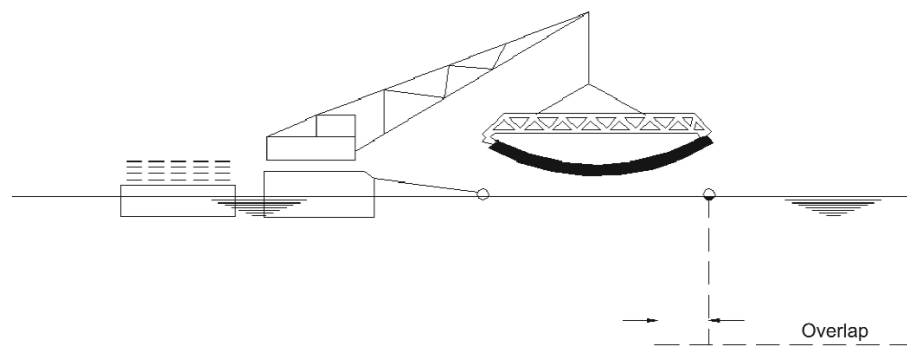

Figure 9.47 Placing a mattress with a crane from a pontoon

9.7.1.3

Bank protection works

Bank protection works are carried out on underwater slopes and can extend to or above the water level (see Sections 8.2.3–8.2.7). Waterborne operations close to the structure are limited by the draught of the floating equipment. In tidal waters the work can be co-ordinated with the tidal state, especially when working at the top end of the slope. The operations can either be waterborne, land-based or a combination of both.

Full granular bank protection

Although geotextiles are often used for bank protection because they are easy to place from the shore, completely granular filters are also applied. As the first filter layer is generally fine, the construction of this layer requires calm conditions, especially around the waterline. This also applies to the use of geotextiles. Considerations other than the occurrence of turbulent water conditions apply, therefore, when constructing a completely granular bank protection, eg sufficiently coarse sub-base material.

The various armourstone layers can be placed by land-based plant if within reach. Where this approach is insufficient, a floating crane may be used. It is good practice to start placing at

the toe of the slope and work upwards to ensure good interlock patterns. Working down the slope should be considered only for very shallow gradients and needs very tight placement.

Bank protection using geotextile covered by armourstone

Geotextile placed using land-based methods is unwound downwards from the top of the slope, after the slope has been trimmed and graded. After unwinding, the geotextile is fixed at the lower end of the slope with sandbags, stones or pegs placed by divers. For waterborne placement, the geotextile may be unrolled from a pontoon in a downward direction (see Figure 9.48).

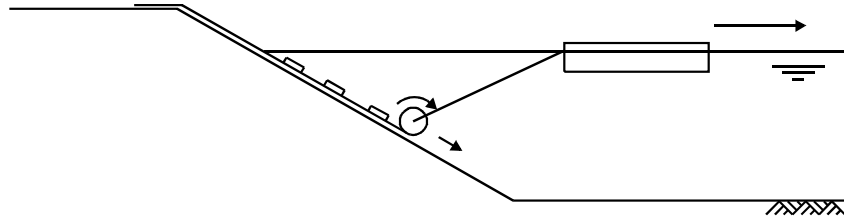

Figure 9.48 Placement of geotextile by unwinding it down the slope

After the geotextile has been placed, stone layers can be added as ballast with land-based plant if its reach is sufficient. If not, a floating crane or a side stone-dumper can be used. Placing should be performed from the lower end of the slope in an upward direction (see Figure 9.49).

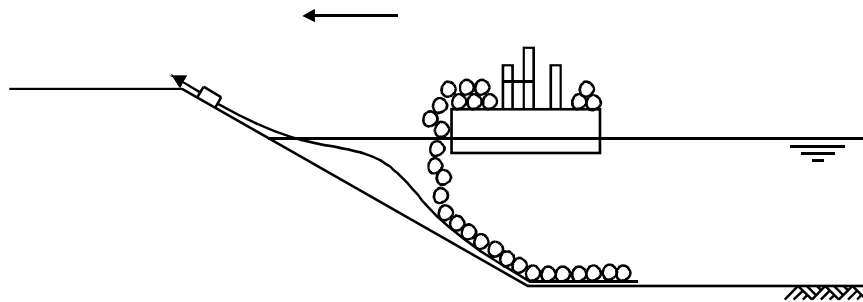

Figure 9.49 Covering geotextile with armourstone in an upward direction

Bank protection using filter mattress covered by armourstone

Filter mattresses with stiffeners such as fascines are floated into position above the required position, during sufficient high tide. The mattress is then anchored to the shore at the top end of the slope (see Figure 9.50). The lower end of the mattress is kept in position with a beam or a sinking pontoon, often when there is a current. Non-buoyant mattresses can be placed by a crane with a frame, as described in the following section. When the mattress is anchored in position it is ballasted with armourstone, again in an upward direction.

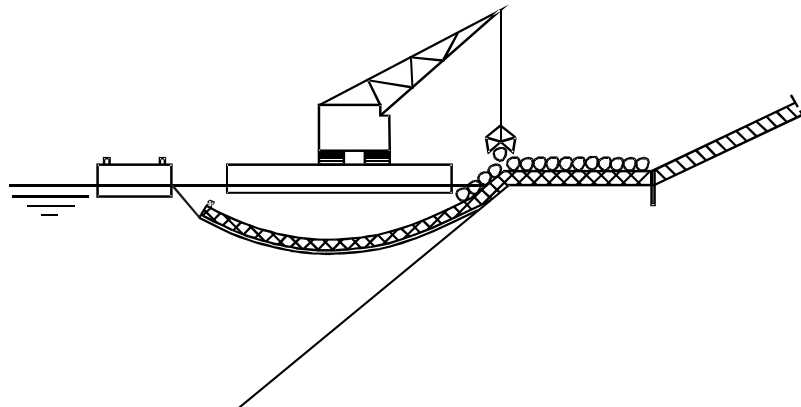

Figure 9.50 Anchoring the top of the mattress

Bank protection using prefabricated mattress with fixed ballast including gabion mattresses

Prefabricated mattresses can be placed either by a floating crane or by a land-based crane with a frame (see Figure 9.51). If the fixed ballast is sufficient to withstand the current and wave action, dumping stones on to the mattress may be unnecessary.

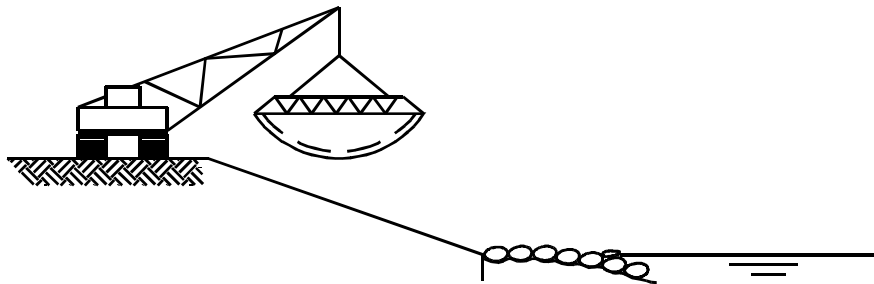

Figure 9.51 Placement of prefabricated filter mattress by crane provided with a special frame

9.7.2 Construction of breakwaters

9.7.2.1 General

Characteristics of rubble mound breakwaters include:

- they are usually constructed entirely of armourstone, but may incorporate concrete armour units
- they have to be constructed under exposed conditions.

The construction method should ensure that damage arising from wave attack during construction is minimal and that exposed underlayers are covered by protective layers as soon as possible. A common distance between the workfront for layers of different materials is 25–50 m, depending on the speed and the method of construction, as well as on the degree of exposure of the site.

Breakwater construction requires large quantities of quarried rock (see Figures 9.52, 2.5 and 6.31), which often have to be supplied from distant quarries. The availability of suitable armourstone near the site can affect the design and transport methods as well as the construction method of the breakwater.

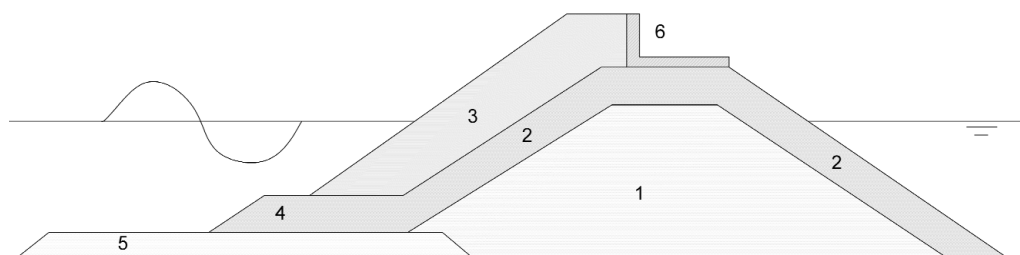

Figure 9.52 Typical cross-section of breakwater structure

The typical components of a breakwater are shown above in Figure 9.52.

- 1 Core.
- 2 Underlayer.
- 3 Armour layer.
- 4 Toe, or possibly a berm.
- 5 Scour protection.
- 6 Crown wall.

The following sections examine the construction of these breakwater components and compare land-based with waterborne operations. A further section is devoted to the placement of concrete armour units, which are often applied in breakwater armour layers.

Detached breakwaters and groynes are two other types of structure with construction aspects similar to those of breakwaters. The functional requirements for groynes and detached breakwaters permit a relatively narrow crest. In many instances, however, the use of land-based equipment for construction requires a wide crest for plant access. Groynes can be constructed on sandy beaches and in the tidal zone. Construction is restricted because of the limited depth and exposed conditions. If wave conditions permit, floating equipment may be used to construct the offshore section. Land-based equipment is used to construct the onshore section and, at low water, part of the seaward section. For the construction of detached breakwaters either waterborne equipment or land-based equipment can be used. In the latter case, access is provided by means of a temporary causeway or a landing facility.

Crown wall

Breakwaters can be provided with a crown wall (see Figures 9.52 and 6.27). These may consist of either precast concrete elements placed on top of the rubble structure, or elements that are cast *in situ*. A stationary heavy-duty crane is used to place precast elements and may be the same crane that is used for placing heavy armour units.

9.7.2.2 Land-based breakwater construction

For a land-based operation, the construction equipment must be able to gain access to the crest of the core, and this criterion can dictate its elevation and width. The width should be sufficient for practical execution of the works. The temporary crest should rise above high water or, in a tidal location, be accessible during a significant part of the tidal cycle. If the core material is placed around and above the waterline, it is vulnerable to wave attack during construction and the next layer may need to be placed shortly after construction of the core.

It may not be possible to drive vehicles with rubber tyres over rockfill. However, by spreading fines over the surface with a bulldozer it should be possible to maintain access on stones up to 1 t. If the design does not permit such an impermeable layer to remain in place, the fines may have to be partially removed afterwards by water jetting. This is a costly operation and should be implemented only when absolutely necessary for stability reasons. Access can also be obtained by using crawler mats or by creating a temporary roadway next to the breakwater.

In spite of these restrictions, land-based construction is normally more economic than marine placing, particularly if material is transported from the quarry to the construction site by land.

A typical plan view of a land-based operation is shown in Figure 9.53, split into six phases.

- 1 Placing of quarry run core by dump trucks.
- 2 Placing remainder of core by crawler crane and/or excavator.
- 3 Placing scour protection with a crawler crane.
- 4 Placing of underlayer by crawler crane or excavator.
- 5 Placing of toe on seaward slope by crane or excavator.
- 6 Placing of armour layer on seaward slope by crane or excavator.

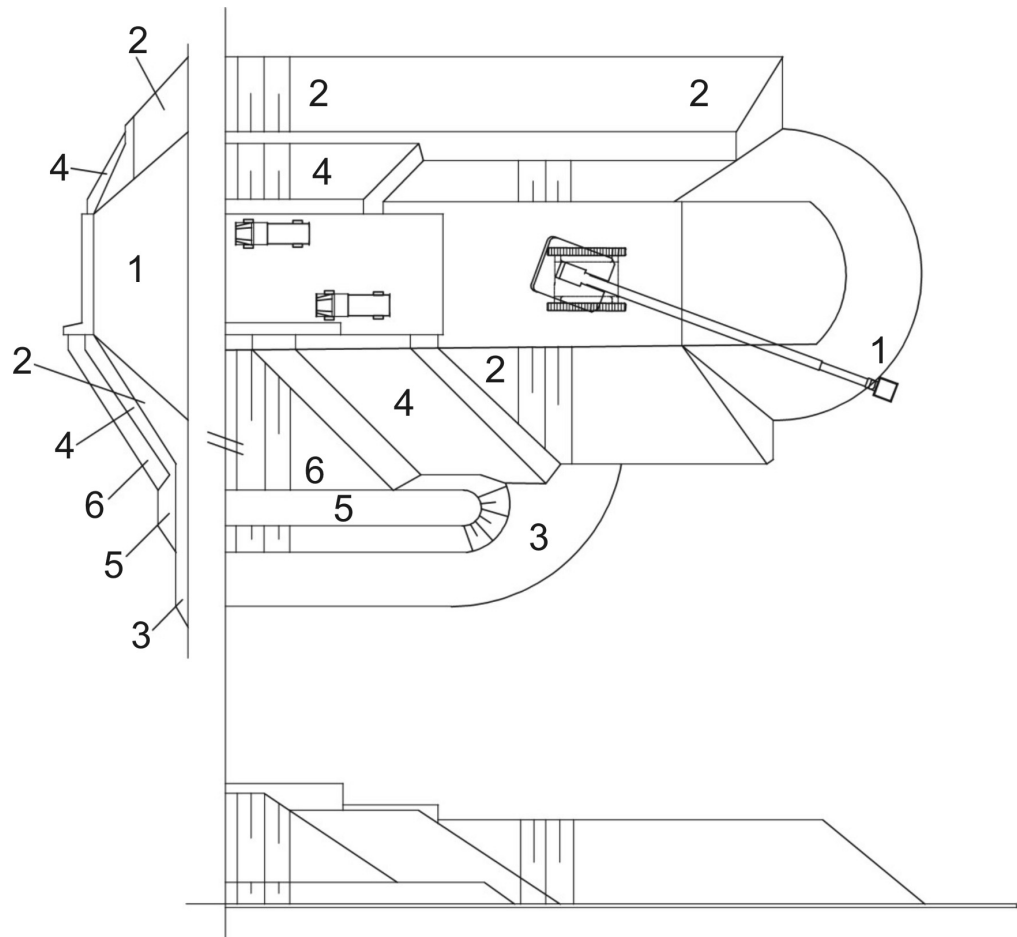

Figure 9.53 Typical plan view, side view and cross-section of land-based breakwater construction

Land-based core construction

Rockfill can be placed either by direct dumping from trucks or loaders, or by using a crane. Direct dumping of wide gradings can result in segregation, as larger stones will roll down and smaller fractions will stay on top. This gives a poor filter structure on the sea bed. Furthermore, a steep side-slope of about 1:1.3, depending on stone angularity, will be achieved. It will be necessary to place any core material required outside that slope line by crane. Direct dumping is the most economic method.

In the case of land-based construction, the crest width of the core is usually dictated by the space needed for safe and smooth use of the equipment on the crest. Dump trucks should be able to pass cranes and other trucks and to tip and turn. Indications for minimum crest dimensions dictated by the equipment are given in Figure 9.54. In many cases the type of crane required for the construction of the toe and armour layer dictates the crest width (see Figure 9.56 in Box 9.1). Figure 9.55 shows an example of a breakwater construction with expansions along the core to enable passing and turning of construction vehicles.

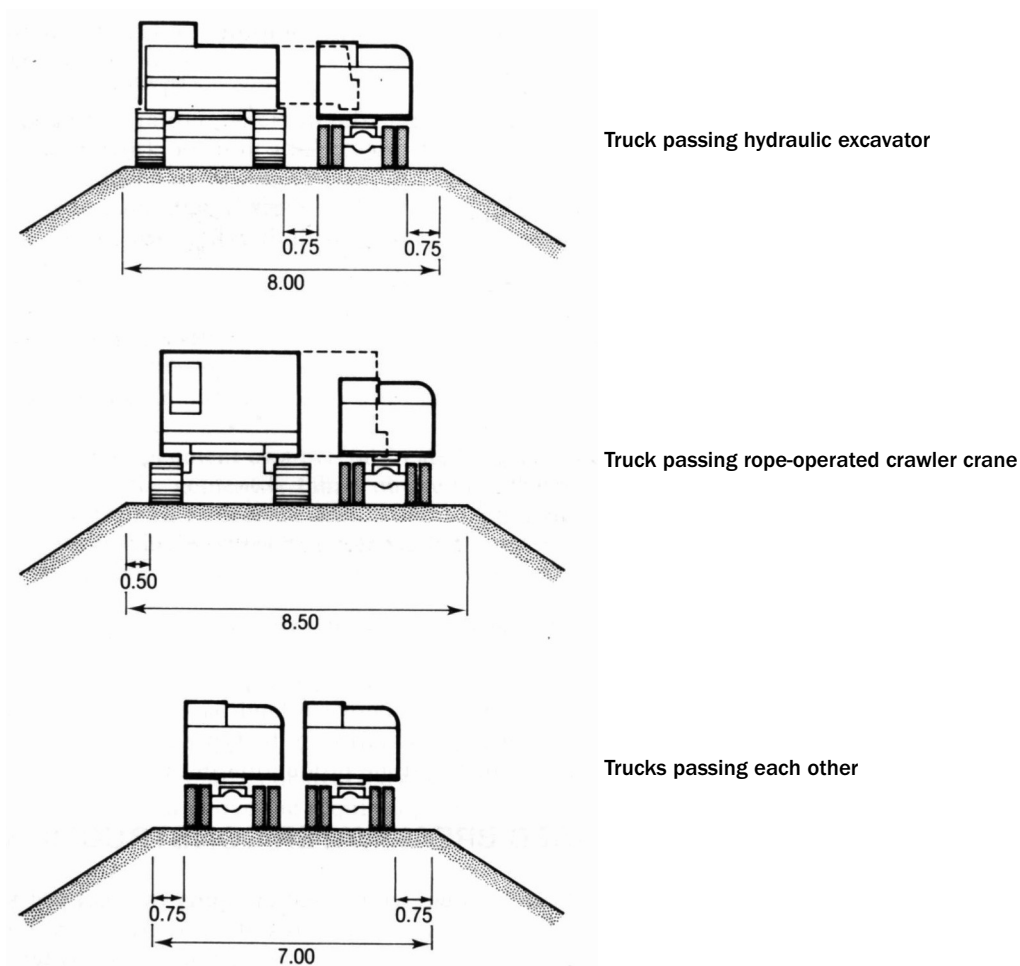

Figure 9.54 Space requirements at breakwater crest (dimensions in metres)

Core material placed by cranes is usually supplied by dump trucks and the capacity of the crane will determine the progress of the work. Cranes can use an open-tine grab or a cactus grab or clamshell to dig into the stock of core material dumped by trucks, or work with skips or rock trays which are filled by a loading shovel or directly by dump trucks. In the first case, space should be provided for a shovel or front-end loader and a truck. In the latter case, heavy cranes are required, which need considerable space on the breakwater.

It may be possible to use sand as a core material. To avoid wide cross-sectional profiles in this situation, rock bunds are placed to contain the sandfill. Alternatively, if economics and the wave climate permit, a wide substructure of sand can be made with gentle slopes. In many cases, the slope on the seaward side is covered with a scour protection as construction progresses.



Figure 9.55 Placement of armour layer, showing expansions for turning and passing along the crest of the core (courtesy Van Oord)

Box 9.1 Widening the crest by reducing the crest level during construction

In the case of the Zeebrugge breakwater (see Figure 9.56), the 10 m wide crest was not wide enough for dumpers to turn and pass the crane during the stage of armour units placement. Either a wider structure would have to be designed or a wider construction road established at a lower level. However, a lower level would result in more downtime because of overtopping waves. A compromise was found at level of +6.8 m, where the total width of the core plus the adjacent filter layers was 13.7 m, enabling an American Hoist-11.310 crane to work and dumpers to pass. This lower level also reduced the reach of the crane necessary to place the concrete blocks at the toe of the slope.

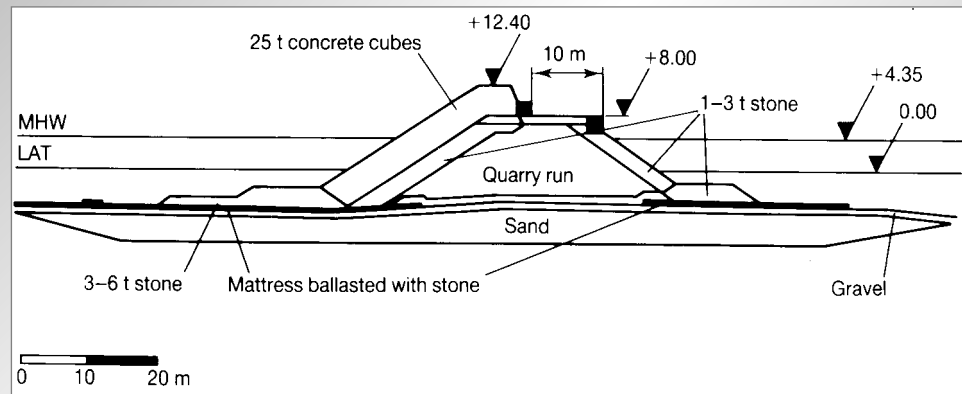

Figure 9.56 Cross-section of Zeebrugge breakwater

Land-based placement of the underlayer

The underlayer can also be placed by dump truck, but it will need to be trimmed afterwards to bring the material to the required profile. Excavators, which require a work platform at least 5 m wide, may be used for this. Long slopes and heavy armourstone of more than 2 t are the limiting factors. The underlayer may also be tray-placed.

Land-based construction of the toe, berm, scour protection and armour

If construction is purely land-based, the scour protection will be placed after construction of the core. However, considerable scour may occur during the construction of the core as a result of the contraction of the current around the advancing head of the structure. This

scour may necessitate the use of larger quantities of core material but can be prevented by providing protection with a stone-dumping vessel before the core construction.

In a land-based operation, the scour protection, toe, berm and armour all demand cranes with sufficient reach. Excavators cannot be used, so rope-operated crawler cranes are necessary. The smaller armourstone in the berm and scour protection is placed using a skip or tray.

The capacity of a crane is determined by the maximum mass of stones plus container at the longest reach, ie *EUL* of the stone grading. Ultimately, the stones at the toe and the berm of the structure determine the type and size of crane required. For large breakwaters in deep water two cranes can be used. First a large crane can place the toe and the lowest part of the underlayer and armour layer, after which a smaller crane can follow to place the top part of the underlayer and the armour layer.

It is important to note that the mass of a grab for core and armour respectively used by these cranes is 30 per cent of the maximum payload. To avoid this loss of lifting capacity when handling large armour stones, eyebolts can be provided. Diligence is required to ensure that the eyebolts are adequately designed and certified for the task. If core material for bed protection is tray-placed, the mass of the container is about 15 per cent of the payload. The relationships between masses, reaches and hoist moments are discussed in Section 9.3.3.

The buoyancy of the stones can be used to extend the reach (see Figure 9.57). This figure illustrates the lifting capacity as a function of the horizontal distance to the crane axis. By keeping the element under water during the placing operation, the reach in this example can be extended by some 12 m.

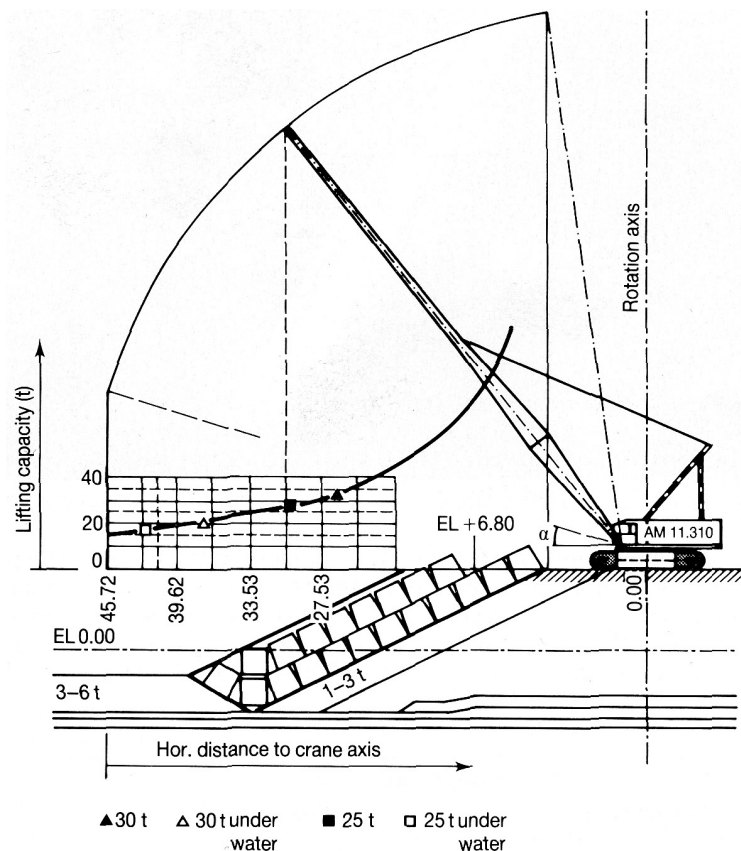

Figure 9.57 Extending the crane reach by making use of buoyancy

The capacity, the lifting speed, the vertical movement of the boom and the swing speed are important properties of a crane suitable for placing armourstone. Typically, lifting cranes have one main drum for the lifting rope, which is usually reeved, plus a smaller drum for the

jib rope, so the load is lifted relatively slowly. These cranes can be used for placing heavy concrete elements. Grab cranes have a double main drum, one for the grab lifting rope and one for lifting the closing rope, which should be able to lift the load of the grab plus contents. The operation is carried out with a single rope so that the lifting speed is much higher. Lowering is often possible in free-fall mode, which is unsuitable for placing concrete elements. Single-rope operation means that much less lifting capacity is available. Guide ropes are useful to prevent the load from swinging too much and to allow quick positioning of the grab. The most suitable cranes for this kind of operation are derrick cranes, which have the same lifting capacity over the full reach of the boom. This makes it possible for the boom to move quickly up and down, resulting in easier and quicker positioning of the load into the works.

The capacity of a crane required to place heavy armourstone elements, whether land-based or placed on a pontoon, is illustrated in Figure 9.58 – breakwaters constructed in Zeebrugge, Arzew and Ras Lanuf. In the diagrams the crane capacity is shown in tonne-metres (tm) as a function of the crane reach operating either from the breakwater crest or from a pontoon.

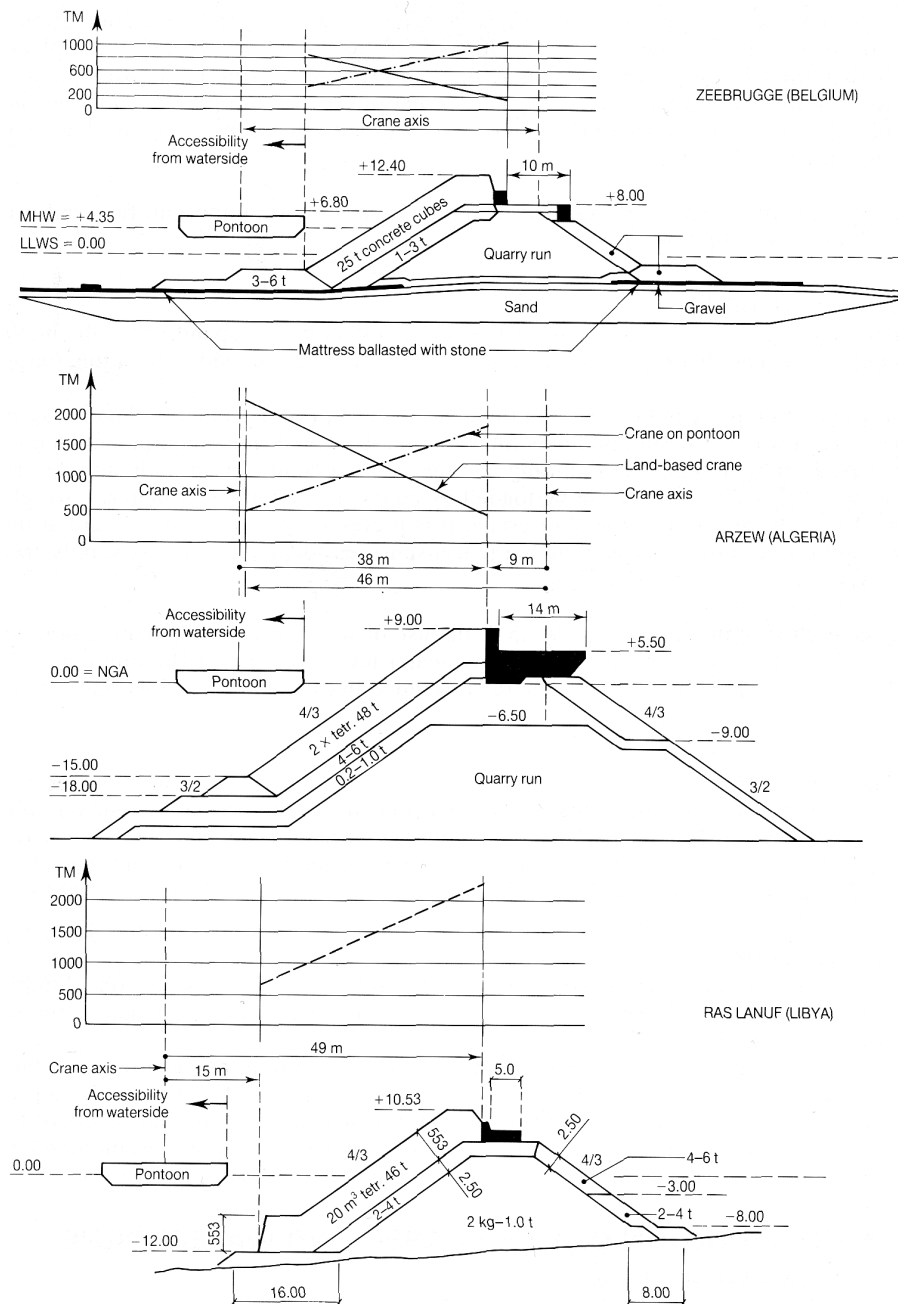

Figure 9.58 Examples of operational conditions for placing armour units by crane for rubble mound breakwaters at Zeebrugge, Arzew and Ras Lanuf (dimensions in metres)

9.7.2.3 Waterborne breakwater construction

Principal reasons for adopting waterborne transport and placing include:

- insufficient available width and/or level of the crest of the breakwater
- congestion problems on the breakwater when using land-based equipment if large volumes of stone have to be placed under water
- economics – depending on the quarry's location (inland or coastal) and the transport distance, marine operations may be more economical than land-based operations
- crane reach – for breakwaters in deep water with long slopes or narrow crests or for placing berms, the crane reach needed may mean that it is impractical to use land-based plant operating from the crest of the breakwater. In these situations, direct dumping from barges is often possible. Floating cranes may be used to overcome reach problems, using rock trays if appropriate.

For floating equipment, the water depth and the exposure to swell and/or waves and currents are important factors affecting overall downtime during construction.

A typical plan view of a waterborne operation is shown in Figure 9.59, which comprises five phases.

- 1 Placing scour protection, from side stone-dumping vessels for example.
- 2 Placing of quarry run core from split-hopper barge (up to 3 m below water level), then tipping with wheel loader from flat-top barge or by floating crane.
- 3 Trimming of slopes and placing of underlayer by floating hydraulic excavator and/or floating crane.
- 4 Placing of toe on seaward slope by side stone-dumping vessel or floating crane.
- 5 Placing of armour layer slope by floating crane.

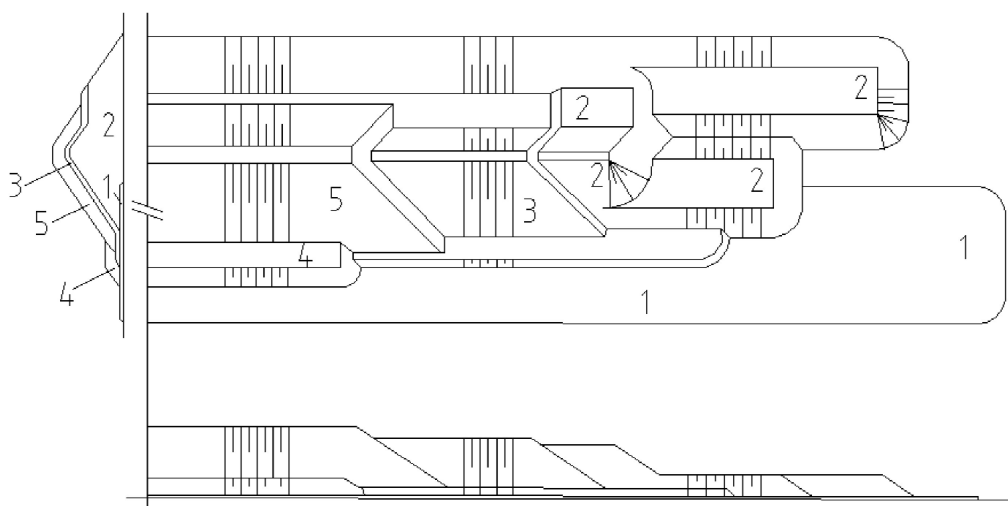

Figure 9.59 Typical plan view, side view and cross-section of waterborne breakwater construction; equipment not shown

Waterborne scour protection and filter construction

Before placing the core material, bed protection may be required to prevent scour from contraction of the current around the core. The construction aspects of these structural elements are described in Section 9.7.1.

Waterborne core construction

Waterborne construction of the core is performed by self-unloading barges such as split-hopper barges or side stone-dumping vessels. To supply the armourstone, floating cranes can be used in combination with barges. However, if they are not sheltered by the newly constructed structure, the workability and accuracy of floating cranes is limited.

Depending on the draught of the vessel, the use of self-unloading or split-hopper barges to dump the core can continue up to some 3 m below low water level. If the tidal variation is large, further dumping can be performed during high tide to create a higher core. When this method is used the core will be more vulnerable to wave attack during low tide. The dumping of the core by a split-hopper barge is uncontrolled, so it may be necessary to use floating cranes or side stone-dumpers for trimming or placing extra material. Side stone-dumpers are more suitable for construction of the core because their accuracy is greater at higher outputs.

Waterborne toe construction

The toe construction requires high precision because the quality of the toe affects the placement of the armour layer. A side stone-dumping vessel or a crane barge can provide such precision. Gravel-size gradings can be placed using modern trailing suction hopper dredgers (see Section 9.3.5).

Waterborne construction of the underlayer

If the underlayer is made of the smallest *heavy armourstone grading*, 300–1000 kg, a side stone-dumping vessel can be used. It may be necessary to trim the underlayer to ensure accurate placement of the following armour layer. If large stones are required, a floating crane should be used.

Waterborne construction of the armour layer

A side stone-dumping vessel may be used for construction of an armour layer of relatively small size heavy grading, 1–3 t. No precise limit to the maximum stone size can be given, as practicality also depends on the sea conditions in which the vessel can operate. Often specifications do not permit the use of this method, as armour stones need to be placed individually in order to build the armour layer up into a proper two-layer construction. Dumping may be a good option for the underwater section, $1.5-2 H_s$ below low water level, as the placement is less critical for this section.

When dumping is impossible because of the required accuracy of placing, pontoon-mounted cranes are common for heavy armourstone gradings (> 1 t). For the accurate placement of large armour units, cranes operate from self-elevating platforms (jack-ups) so they are independent of sea conditions. However, keeping the barge delivering the stones alongside may be difficult. The limiting conditions for such an operation may be stricter than when placing by a crane on a barge.

1

2

3

4

5

6

7

8

9

10

9.7.2.4 Combination of land-based and waterborne construction

Land-based and waterborne operations are often carried out in parallel when planning requirements dictate the need to operate on two or more fronts of a breakwater simultaneously. Another reason for this may be the need to reduce erosion at the working front by placing bedding layers and the lower sections of the breakwater from marine vessels, before building the superstructure by land-based equipment.

To illustrate the various stages in the construction of a breakwater in relation to the types of equipment used, an example of a typical construction sequence for the different layers of a breakwater is given below (see Figure 9.60). It comprises seven phases.

- 1 Placing scour protection from side stone-dumping vessel.
- 2 Placing of quarry run core from side stone-dumping vessel or split-hopper barges up to 3 m below low water level.
- 3 Placing of quarry run core from 3 m below water upwards by dump trucks.
- 4 Trimming of slopes and placing of underlayer by crawler crane or hydraulic excavator.
- 5 Placing of toe on seaward slope by crawler crane.
- 6 Placing of armour layer on seaward slope by crawler crane and/or hydraulic excavator.
- 7 Placing of crown wall using heavy-duty crawler crane or cast *in situ*.

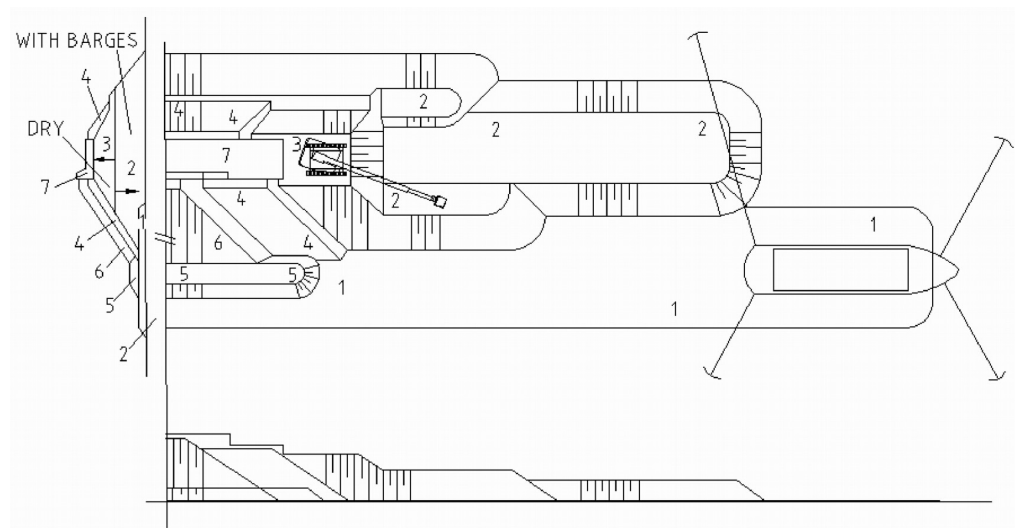

Figure 9.60 Plan view, side view and cross-section of simultaneous land-based and waterborne breakwater construction

9.7.2.5 Use of land-based equipment versus waterborne operations – summary of issues

The following list summarises the considerations for use of land-based or waterborne equipment as discussed earlier in Section 9.7.2.

Land-based operation	Waterborne operation
<p>Cross-section</p> <ul style="list-style-type: none"> ● crest elevation and crest width is determined by the dimensions of the cranes and trucks and acceptable workability due to overtopping by waves and spray ● flat slopes and wide berms may exceed maximum reach of cranes. 	<ul style="list-style-type: none"> ● the crest level is determined by hydraulic stability and overtopping requirements ● the core level is preferably 3 m below LW to allow free dumping of material from barges.
<p>Length-section</p> <ul style="list-style-type: none"> ● the workfront is necessarily short. The various construction phases follow each other closely since works are concentrated around the position of the crane(s). 	<ul style="list-style-type: none"> ● the workfront is extended over a large area to allow for sufficient manoeuvring and anchor spaces.
<p>Logistics</p> <ul style="list-style-type: none"> ● all supplies are over the breakwater; the narrow access limits the daily supply ● short breakwaters are most suitable for land-based operation ● existing infrastructure can normally be used for transport between the quarry and the site ● work is generally restricted to one front. 	<ul style="list-style-type: none"> ● a loading terminal has to be provided for the barges before actual construction can start ● the length of the breakwater forms no logistic limitation ● work may be initiated and proceed at different locations.
<p>Morphology</p> <ul style="list-style-type: none"> ● current concentrations may create scour holes at the temporary head, as it is difficult to construct extensive scour protection. 	<ul style="list-style-type: none"> ● a scour protection can be made in advance to avoid the development of scouring holes.
<p>Limiting factors</p> <ul style="list-style-type: none"> ● reach and capacity of the cranes effectively limit the cross-section and progress of the work ● breakwaters in deep water can become troublesome. 	<ul style="list-style-type: none"> ● a water depth of 2–4 m is required. Sometimes work is only possible in part of the tidal cycle ● barges and other waterborne equipment are not as widely available as land-based equipment and their use requires specialised personnel.
<p>Environmental constraints</p> <ul style="list-style-type: none"> ● available construction time is determined by the freeboard between working platform and water level. 	<ul style="list-style-type: none"> ● available construction time is determined by the allowable motions of barges and floating equipment. Downtime is longer than for land-based operations ● crane pontoons are particularly sensitive. Excessive impact between barges and pontoons, forces on the crane and risk of collision with the breakwater precludes crane operations in waves with $H_s > 0.5$ m to 0.75 m.
<p>Damage during execution</p> <ul style="list-style-type: none"> ● there is a high risk of damage because the core and small-size underlayer extend above the water level ● the length of the unprotected structure is limited ● in the case of an extended construction period the risk of damage increases proportionately. 	<ul style="list-style-type: none"> ● the risk of damage to core and underlayer can be limited by keeping the top of this material at a low level ● if damage occurs, it is generally over a considerable length.
<p>Planning</p> <ul style="list-style-type: none"> ● lead time for construction is determined by quarry preparation ● mobilisation time for land-based equipment can be short ● progress of construction depends on one or two cranes that are critical for a number of construction phases ● equipment is readily available. 	<ul style="list-style-type: none"> ● the lead time for construction might be long if special terminal facilities have to be constructed ● the mobilisation time for marine equipment is longer ● at critical phases production can be increased by introducing more equipment and working in parallel ● large stockpiles or high production rates are required for the efficient operation of marine equipment ● availability is limited because of specialised nature of equipment.
<p>Maintenance and repair</p> <ul style="list-style-type: none"> ● if the breakwater is designed with a sufficiently wide crest element, maintenance from the superstructure can be done with standard land-based equipment. Frequently this is not the case and floating equipment is required. 	<ul style="list-style-type: none"> ● maintenance and repair can only be done with floating equipment.

9.7.2.6 Placement of concrete armour units

Placing concrete armour units can be a time-consuming part of the breakwater construction because of the large number of units that should be placed and the constraints that exist on the placement procedures for slender and highly interlocking armour units. Placement rates typically range between three and 15 units per hour and may vary significantly with the environmental conditions (wave conditions, currents, visibility etc). Suitable and reliable equipment should be selected in order to achieve reasonable placement rates.

The breakwater slope should be properly profiled and, to facilitate placement, the median mass of the armourstone in the underlayer should not exceed 15 per cent of the armour unit mass (see Table 5.36 for details and see Section 5.4 for further discussion on filter requirements and sizing of underlayers). Deviations of the slope surface of the underlayer from design levels and slope should not exceed the nominal stone diameter D_{n50} of the underlayer. Tolerances are discussed further in Section 9.3.7 (Table 9.7).

Armour units are placed with a sling, which is equipped with a quick-release hook operated by a tag line (see Figure 9.61) and a guide line to locate the unit in the correct position, while a clamp is used to place cubes.



Figure 9.61 Use of a quick-release hook (courtesy Interbeton)

Most concrete armour units are placed randomly in relation to the orientation of the units, but are located on a predefined grid. In order to place the units accurately on this grid, the crane should be equipped with a GPS antenna on the boom. Single-layer concrete armour units like Accropode, Core-loc and Xbloc are placed on a staggered grid (see Figure 9.62).

The placement of single-layer armour units starts at the breakwater trunk in a relatively sheltered area with the placing of a triangular section. Subsequently an armour unit is added to the first row, at the breakwater toe, to the second row resting on two units of the first row: the unit that has been placed before and the neighbouring unit, to the third row and so on. The placing of armour units proceeds with the construction progress of breakwater core and

underlayer(s) and can become a limiting factor for the construction progress. Accurate positioning of the armour units at the breakwater toe first row is essential, especially with respect to the horizontal spacing between armour units. Subsequently, the positioning of the armour units further upslope, ie second row, third row etc will be supported by previously placed units in the row below. It is essential that adequate toe stability is provided to prevent the revetment from unzipping and becoming unstable. In the case of double-layer armour the second layer is installed soon after completion of the first layer.

Where slope distances are not too great, armour units can be placed by a hydraulic excavator equipped with a purpose-built rotating grab equipped with a GPS Receiver so as to achieve the required orientation and position.

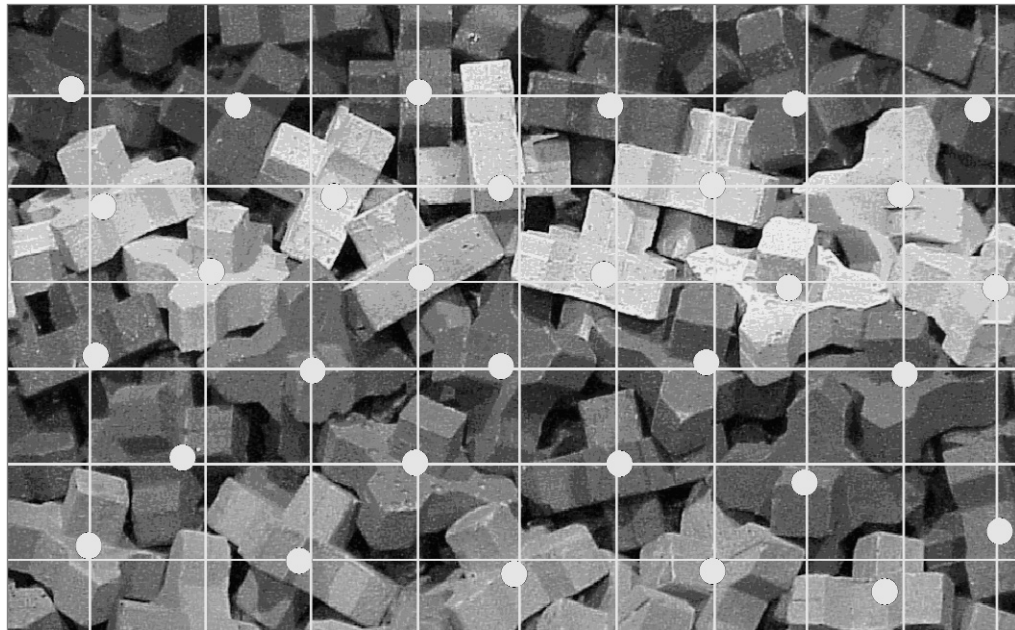

Figure 9.62 Placement of Xbloc armour units in a staggered grid (courtesy Delta Marine Consultants)

Limited visibility complicates the underwater placement of interlocking armour units. Divers may be required to assure proper placement and interlocking of the units. For safety reasons the divers must not participate actively in the placement of armour units, but they can inspect the positioning of the units and, if required, assist in retrieving the sling.

9.7.3 Construction of seawalls

Seawalls are used to protect existing shores and artificial islands (see Section 6.3). In both cases, bunds are put in place and the area behind backfilled with sand. If it is a high construction, several consecutive bunds and backfill layers can be constructed to reduce the volumes required for the bunds (see Figure 9.63). In the case of artificial islands that are surrounded by bunds the ratio of bund material to backfill is small, while for existing coastlines relatively less sand backfill is required. When a new seawall is constructed near the existing shoreline no sandfill is required (ES in Figure 9.63).

Bunds consist of dumped armourstone and, although alternative construction methods using geotubes and geobags are possible, the focus in this manual is on rock bunds.

For seawalls along existing shores, land-based equipment or a combination of land-based and waterborne equipment is used, while floating equipment is used to construct artificial islands.

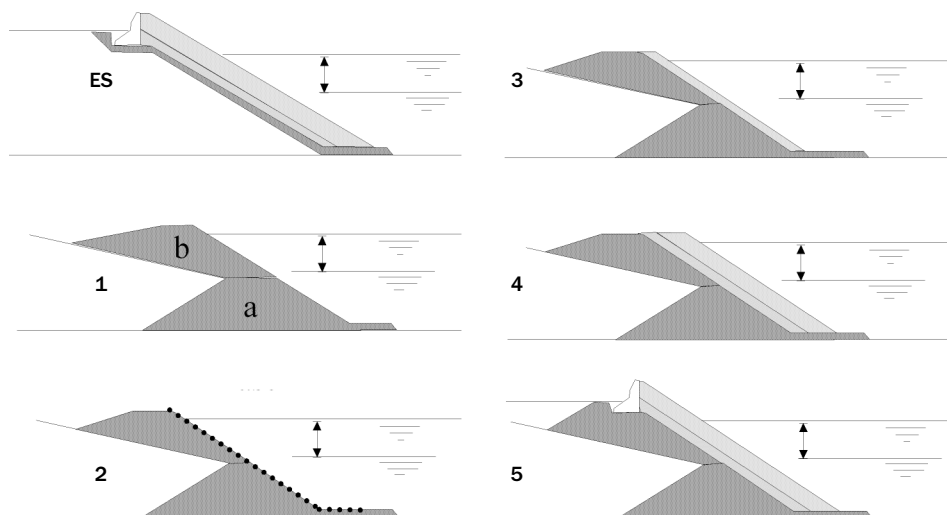

Figure 9.63 Typical construction sequence of a seawall: along existing shore (ES), and along reclamation (stages 1–5)

A typical construction sequence for a seawall protecting an artificial island or a reclamation is shown in Figure 9.63, which illustrates the five stages.

- 1 Placing of stone bunds and sand backfill. Bund (a) is placed by a stone-dumping barge and bund (b) by dump trucks.
- 2 Trimming of outer slope and placement of geotextile. In this example, parts of the stone bund are removed by excavator for use elsewhere in the seawall.
- 3 Placement of underlayer by hydraulic excavator.
- 4 Placement of armour layer by excavator or crawler crane.
- 5 Completion of the top section including crown wall, either precast elements placed by crane or cast *in situ*, and road surface.

Retrieval of bund material

The construction of the bunds can involve an extra volume of quarried rock that is not required for the performance of the structure. Part of this volume can be retrieved by excavators and used elsewhere in the seawall. However, this is feasible only for construction in shallow water and preferably where land-based equipment can be used. At greater depths, retrieving the extra material is not feasible. The volume of extra bund material can be reduced by constructing several smaller bunds. This may not always be feasible, however, as it complicates the construction of the bunds and demands greater accuracy of armourstone dumping.

Degree of exposure to waves

Placement of the geotextile during seawall construction is a complicated procedure. The easiest method is to place the geotextile on the seaward side of the bund, as shown in Figure 9.63 – stage 2. This should be done under calm conditions. If there are likely to be few calm periods, the design and the construction scheme should be changed.

The geotextile should be placed on the landward side of the top bund. The lower reach of the geotextile, and the height of the top bund should be extended only to the level at which washing out of the sand by waves and currents is expected. Below the extent of the geotextile, the washing out of sand can be prevented by constructing sufficiently broad bunds. The turbulence generated by waves and currents, which causes washing out of the

sand, will then dampen out with distance inside the bunds. This construction method is illustrated in Figure 9.64.

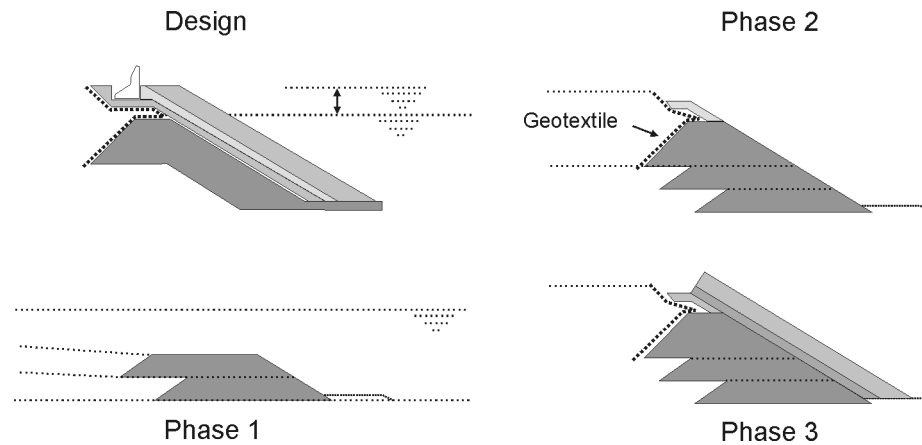

Figure 9.64 Construction of seawall under exposed conditions

The figure shows the first three of the four construction phases.

- 1 Placement of sufficiently broad bunds with waterborne equipment, combined with sand backfill.
- 2 Placement of a quarry run dam up to half tide level with land-based equipment, placement of geotextile on landward side of this dam, placement of sand backfill and of armourstone for the underlayer on upper end of the slope.
- 3 Placement of underlayer and armour layer with a land-based or waterborne crane.
- 4 Completion of top section of the structure (not shown).

9.7.4 Offshore and foundation structures

Bed protection works that are constructed and/or placed offshore require special waterborne methods (see Section 6.4). This involves placement in deep water, working with considerable wave action and solving logistic problems relating to material supply and loading. As a result, dumping from conventional barges may be uneconomic because of:

- wave- or swell-induced movement of barges
- spreading or loss of stone gradings caused by wave and/or current
- segregation of stones.

In such cases flexible fall-pipe vessels (described in Section 9.3.5) can be used. Additional aspects specific to the construction of offshore bed and pipeline protection works are discussed in Sections 9.7.4.1 and 9.7.4.2.

9.7.4.1 Construction of foundation structures

For offshore structures such as concrete gravity structures (CGSs) it may be necessary to prepare a foundation of granular material to ensure that the seabed foundation is devoid of obstructions, pinnacles etc, which could induce high point loads on the CGS after placement. The need for this depends primarily on the stiffness of the CGS. Moreover, the sea bed must be sound enough to avoid differential settlement of the CGS. Depending on the nature of the project, different methods of bed preparation can be used. Ultimately the selection of the desired approach will depend on the structure's sensitivity to earthquake conditions and its stiffness. An example of an approach for foundations using a fall pipe is discussed in Box 9.2.

Box 9.2 A unique approach for a foundation structure utilising a flexible fall pipe

In 2001, a 112 m × 86 m × 52 m-high CGS with a mass of 90 000 t was constructed and installed to supply natural gas to power plants in a water depth of about 45 m. To ensure that reaction forces on the base slab of the CGS were within allowable design limits and no local peak loads could occur, a rock foundation mattress was placed consisting of more than 350 individual mounds of stones, using a flexible fall-pipe vessel (see Figure 9.65). On site, 10 sub-sea transponders were deployed to guarantee accurate positioning of the mounds in the correct place within specified limits of a maximum 0.5 m between the footprint of each mound. Long-range kinematic positioning equipment together with two DGPS receivers was utilised to check the position of the vessel and the lower end of the fall pipe.

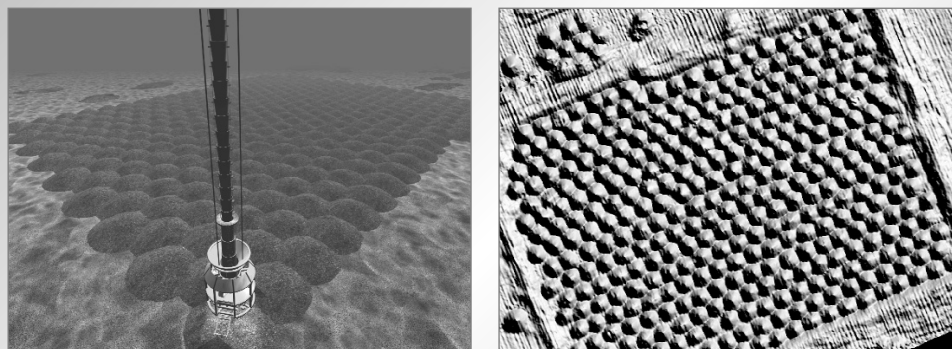

(a) Schematic representation of the dumping process

(b) 3D-terrain model image obtained by multi-beam echosounding of the completed foundation

Figure 9.65 Example of offshore foundation bed constructed by flexible fall-pipe vessel (courtesy Van Oord)

The mounds consisted of 24 000 t of fine gravel. This material was retrieved from a source 200 km away and transported to the site on a flat-top barge, which also acted as the stockpile for the project. Wave conditions at the site were relatively mild: 60 per cent of the time the wave heights were less than 1 m. Currents were also mild, in the order of 0.5 m/s or less. These favourable conditions facilitated the transhipment of the gravel from the barge to the fall-pipe vessel, limiting the downtime attributable to environmental conditions.

Bed and scour protection is often applied around the jack-up legs of offshore platforms and around monopiles for offshore windmills. The design and construction of such rock structures is described in Section 6.4. They are usually constructed in deep water so a fall-pipe vessel can be used to place gravels that are relatively fine (less than about 200 mm). Where larger stones are required the material is placed by any of the methods described in Section 9.3.5. When a foundation structure is placed using side stone-dumping vessels, the accuracy of the placed armourstone will depend on the water depth, rock gradation and the environmental conditions. Layers are dumped by hauling the vessel over the area during dumping. By dumping the armourstone in more than one layer the uniformity of the armourstone layer is also improved, reducing the chance of low spots forming.

9.7.4.2 Construction of pipeline and cable protection

Armourstone is placed to cover pipelines, telecommunications and power cables and umbilicals in offshore locations in deep water. The structure consists of a single armourstone layer or a number of layers forming bunds on the sea bed. These bunds extend on both sides of the pipeline or cable and must provide sufficient cover (see Section 6.4) to protect, stabilise or provide additional insulation. Such cover layers are constructed:

- on the original sea bed in the case of a non-trenched pipeline or cable
- below original seabed level in the case of a pre- or post-trenched pipeline or cable.

The design of the berm structure starts with establishing the size of the armour material, the material that governs the stability of the berm under design environmental conditions or other design loads. If placing the armourstone directly on top of the pipe poses an unacceptably high

impact load on the pipeline or cable, a buffer layer of smaller coarse armourstone can be placed around the pipe or cable. The application of smaller material may be required to prevent erosion of subsoil material through the coarser armourstone, initiating unwanted settlement of the berm structure. When a berm is required to increase the insulation of a high-temperature oil exporting pipeline, specially designed sand-gravel mixtures are placed around the pipeline to minimise heat loss. Consequently, placement offshore requires an accurate positioning system and controlled placement techniques. Side stone-dumping vessels can be used for this in shallow water. Vessels with a flexible fall pipe are commonly used in deeper water (see Section 9.3.5).

9.7.5 Typical river works

Most rock works in rivers consist of bed and bank protection (see Sections 9.7.1.2 and 9.7.1.3). In this section the work method and construction issues of two typical river protection works are examined (see also Section 8.2).

9.7.5.1 Bank protection on sandfill

The work method particularly applicable to a rock-armoured slope to be constructed along the embankment of a canal or river is illustrated in Figure 9.66. The structure is very similar to that of a seawall, but in inland waterways and in tidal areas the construction is carried out in sheltered conditions. This allows trimming of the underlying sandfill to the required slope over the full height and placement of the rock protection in layers on top of the sandfill, rather than the alternating placement of rock bunds and sand backfill (see Section 9.9.3).

The sandfill is often hydraulically placed and depending on the grain size of the sand and the placing method, this results in rather gentle slopes, 1:6 to 1:10, below LW. In the tidal zone, the slope can be as flat as 1:30 for coarse material and up to 1:100 for fine material.

Before the protective armourstone is placed, the sandfill is trimmed to the required slope, about 1:3 to 1:4. Where the lower slope cannot be trimmed from land, it is carried out using a dredger or backhoe placed on a pontoon. As shown in Figure 9.66, the dredged sand may be placed in a temporary stockpile for use in the upper part of the slope, or placed in the works as part of the fill activity. In order to reduce the exposure of the unprotected sand surface to possible tidal and current action, the progress of slope trimming should be adjusted to the progress of placing the armourstone. The armourstone can be placed by using land-based equipment or from the water depending on the length of the slope.

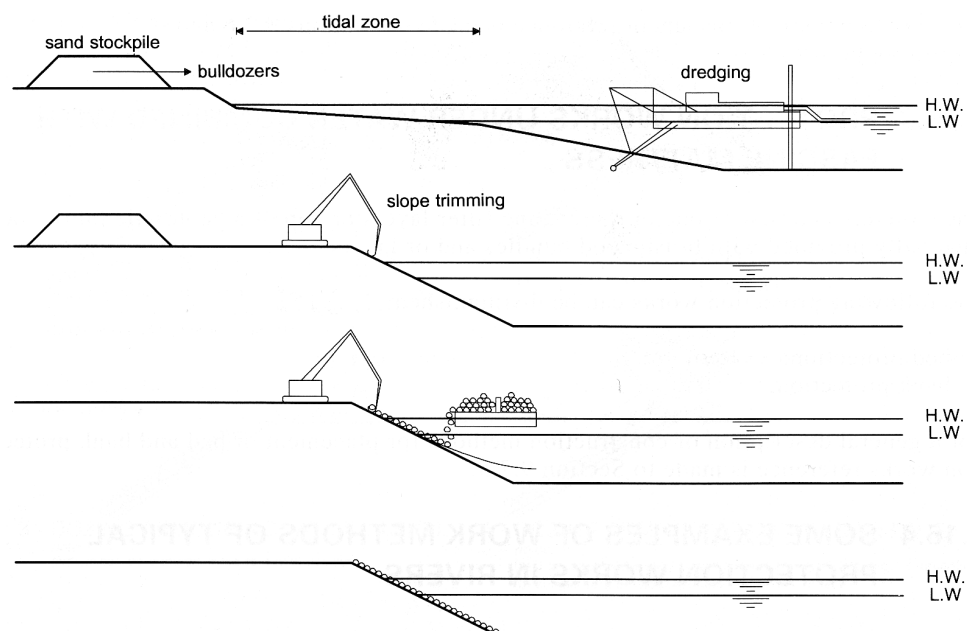

Figure 9.66 Construction of rock armour layer as bank protection on sandfill

9.7.5.2 *Spur-dikes and river alignments*

These structures are found in relatively shallow water and, because of their small size, require small-scale equipment. Spur-dikes consist of sandfill covered by armourstone. Current velocities and the local water depth vary, depending on the river discharge at the time of construction. During periods of low river discharge it may be possible to complete the construction of a spur-dike in the dry. For ease of construction the works should be carried out during the driest season when low river water levels prevail.

If construction cannot be undertaken in the dry, the following construction method can be used. Down to 2 m below water level, sand can be bottom-discharged using small (200 m³ capacity) split-hopper barges. Above this level, sand is placed by a crane mounted on a small hopper dredger. Once the sandfill is above water level, the slopes can be trimmed to the required slope using a land-based hydraulic excavator and the sandfill can then be raised up to the required level. At the head of the spur-dike, sheet piles may be installed in order to resist possible erosion of the soil around the spur head. An excavator is used to push these sheet piles into the sand.

The slope protection can now be placed. At the shore end of the spur-dike, land-based equipment is used to place the geotextile and armourstone. Further into the river and at increasing water depth, mattresses are placed by waterborne equipment. At the sides of the spur-dike, the mattresses are floated into position and pulled up the slope to approximately 1 m below crest level either by hand or using a crane. Care must be taken to ensure that the sections of geotextile fabric overlap each other by at least 1 m. After placing, the mattress is ballasted by armourstone.

Towards the river side of the spur-dike, when sheet piles are used, the mattress is raised to the top. The underlying geotextile should be laced over the top of the sheet piles to prevent sand being washed out. If sheet piles are not used, the procedure described in the first paragraph of this section is implemented.

Finally, a large mattress is brought into position at the head of the spur-dike (see Figure 9.67). This mattress should completely cover its head.



Figure 9.67 *Fascine mattress in position, beginning of ballasting (courtesy Van Oord)*

The capping layer is either constructed by crane, in the case of armourstone protection (see Figure 9.68), or hand-placed when block elements have to be applied.



Figure 9.68 Placement and trimming of spur-dike capping layer (courtesy Van Oord)

To reduce erosion in the construction area, alignment works start at the upstream end and are carried out in a downstream direction. In this case, construction takes place in a more sheltered environment, which reduces erosion. Conversely, where siltation is likely to be the main problem, the order of working is reversed.

9.7.6 Execution of emergency repairs

An emergency repair is performed when a structure is damaged. If the damage is not repaired immediately, severe deterioration or failure of the structure may be expected. When an armour layer is damaged, progressive displacement of the armour layer and washing out of underlayers and core is expected during the next storm event.

Emergency repairs are unplanned and are not a part of the regular maintenance described in Chapter 10. Regular maintenance should be planned in advance and the structure should meet all the relevant design criteria following maintenance.

Emergency repairs generally involve a high level of improvisation, so there are few general rules governing them. As the repair needs to be performed very quickly, the measures applicable depend on the availability of equipment and materials and on the accessibility of the damaged structure. Measures taken in an emergency repair may not always fulfil all design criteria, but they should serve to minimise further damage until a well-planned repair operation can be carried out in the next calm season.

Available land-based or waterborne equipment should be employed for repair work (see Section 9.3). Often land-based equipment cannot gain access to the structure for repair work, even if it was used to build it, so there may be no option but to employ waterborne equipment. As immediate action is often necessary, only the waterborne equipment immediately available can be used and this is not always ideal for the purpose. This may have the following consequences:

- access to the repair area is often restricted, and free movement of equipment is hindered
- as a result, the repair work should be designed as a simple structure
- damage often occurs in the most exposed section of the structure, so even in the following calm period, working conditions may still be affected by the wave and current climate
- placing armourstone may be less accurate than during the construction phase.

Transitions in revetments are contact zones between different types of material in the top layer as well as in the underlayers and, if not accurately designed and built, can be vulnerable to damage. The design should not place transitions in the near-water-level zone, where hydraulic loads are often highest. It may not be possible to restore damaged transitions to their original state during the emergency repair. Filling gaps and holes with filter armourstone, to be covered with heavier armourstone, may be adequate as an emergency measure. Sufficient overlap must be created on top of the undamaged revetment zone around the damaged transition area.

The main requirements to be fulfilled by repair works are:

- to provide stability in order to withstand forthcoming storms
- adequate filter quality to stop material seeping out of the underlayer and base.

Abundant filter armourstone will guarantee a good working filter in these circumstances.

If a bed protection structure is damaged, the result is often a scour hole. Large damaged areas of bed protection consisting of fascine mattresses can be protected by sinking new fascine mattresses. In these cases it is not necessary to connect the new mattresses tightly to the existing ones. Some space between the newly placed mattresses and the existing mattresses is acceptable. The mattresses can easily deform in response to any initial scour of erodible bed material in the relatively small gaps. This reduces the exposure of bed material to hydraulic loads and the erosion process will gradually slow down and eventually stop.

It is not always possible to sink fascine mattresses in the gaps of a damaged bed protection. Repair is completed by filling the scour hole with filter armourstone. Subsequently, the rockfill is covered by a top layer of larger armourstone, or by sinking fascine mattresses. The newly placed mattresses should overlap the existing mattresses by a sufficient amount.

9.8 QUALITY CONTROL

9.8.1 Placing methods and packing

9.8.1.1 *Armourstone*

Core materials, as well as standard and non-standard coarse and light gradings, are said to be **bulk placed** when positioned in the structure by dumping from a range of equipment (see Sections 9.3.2 and 9.3.4). Volumetric (or layer) porosities, n_v , based on bulk filling without compaction can be estimated by using methods given in Section 3.5.1. In this case the grading width, eg D_{85}/D_{15} , is the most important factor.

Heavy armourstone for use in underlayers or cover layers is termed **individually placed** when machines are used to place one stone at a time. Both the stone shape and the way in which the armour stones are placed in the structure affect the tightness of packing, the layer thickness and the stability achieved. Explicit guidance is given in Section 3.5.1. In general, heavy armour stones are individually placed with hydraulic excavators provided with orange-peel grabs, three- or five-tine single-hinge grabs or powerforks, or buckets. Grabs on cranes can also introduce a measure of orientation and placement control through guide cables, but highly skilled operators and slow placement rates are necessary (Wegner, 2004). Controlled placement is discussed further in Sections 9.3.3 and 9.3.5.

Guidance in Section 3.5.1 refers to block shapes and four types of individual placement.

- 1 Random placement.
- 2 Standard placement.
- 3 Dense placement.
- 4 Specific placement.

Random placement is without control of orientation and should not be assumed to be tighter than if the blocks are placed out of view under water by a single cable release from a crane using a spatial positioning grid. Void porosity and layer thickness coefficient values applicable to standard placement may be used, recognising that void porosity may be 0–2 per cent higher.

Standard placement is where minimum orientation control is applied so that the block attitude is effectively governed by its orientation in the stockpile before lifting. However, a minimum of **three points of contact** within the layer being placed should be ensured, ie excluding blocks effectively beneath, so that in some cases the piece of armourstone can be rotated to achieve the three-point contact. This rotation can be achieved with the extra degree of freedom provided by an orange-peel grab and single-hinge grabs or powerforks. This is hard to achieve with an excavation bucket or a grab operated from a wire-rope crane.

Dense placement involves the rotation of armour stones until the orientation achieved is expected to give the maximum number of point contacts and minimum voids. Individual stones are removed and replaced if necessary. This requires multi-tine grabs, ideally the powered rotating orange-peel type (see Figure 9.17).

Specific placement is used when the procedures coupled with stone shape constraints are specified to be other than random, standard or dense. An example is the placement of parallelepiped blocks with long axes normal to the layer, as employed in jetties of the US Pacific North West (Wegner, 2004).

Box 9.3 presents as-placed packing (or bulk) densities obtained from several structures based on land-based surveys. The data illustrate the variability that can occur in as-placed packing densities.

9.8.1.2

Concrete units

Concrete armour units require a specific positioning method (see Section 3.12). Quality control needs to be adapted to each unit type along the following lines.

- 1 Units placed in a double or single layer. Visual check is satisfactory with daily record.
- 2 The units placed according to a given positioning pattern such as rectangular, lozenge or other pattern. Visual check and position recording system are satisfactory, together with the recording of the location of each numbered unit. Recording the location of each unit allows for later retrieval of the fabrication details in cases of breakage.
- 3 Units to be placed in orientated attitudes, with all the units having the same orientation compared against a reference such as the crest line or with the units placed in deliberately varied attitudes, with neighbouring units having different attitudes. Visual check is satisfactory; photographic records are preferable.
- 4 Each unit must be in contact with the underlayer or with the first layer of armour units. Visual check is satisfactory.
- 5 Placing density is stipulated. The number of units in each zone and the surface area of this same zone must be recorded.

Divers need to check that the units have been correctly placed under water, in particular with regard to unit keying.

Box 9.3 Examples of site parameters and summary statistics (Latham et al, 2002)

Site	Apparent rock density $\rho_{app}(\text{t/m}^3)$	As-placed (or bulk) density $\rho_b (\text{t/m}^3)$	Layer thickness coefficient $k_t (-)$	Volumetric (or layer) porosity $n_v (\%)$	Contract payment by mass or volume	If n_v was based on trial panel
East Coast 1	2.73	1.85	-	32.2	V	X
East Coast 2	2.73	1.72	-	37.0	V	X
South 1	2.65	1.71	-	35.5	M	X
South 2	2.60	1.82	-	30.0	M	X
South 3	2.65	1.72	-	35.1	V	X
South 4	2.64	1.82	-	31.1	V	X
South 5	2.69	1.78	-	33.8	M	X
South 6	2.67	1.90	-	28.8	V	✓
South 7	2.75	1.90	-	30.9	M	X
South 8	2.65	1.65	-	37.7	V	X
South 9	2.65	1.70	-	35.8	V	X
South 10	3.10	2.00	-	35.5	V	X
South 11	2.65	1.70	-	35.8	V	X
Beesands	2.76	1.90	-	31.3	V	✓
North Wales 1	2.66	1.81	-	32.0	V	✓
North West 1	2.72	1.77	-	35.0	M	X
North West 2	2.70	1.82	-	32.6	V	✓
North West 3	2.70	1.70	-	37.0	M	✓
Immingham - s	-	1.63	1.03	40.1		✓
Immingham - ds	-	1.65	0.92	39.2		
Reculver - ds	-	1.77	0.94	34.4		✓
Shoreham - s	-	1.90	0.71	30.0		✓
Shoreham - ds	-	1.89	0.77	30.1		
Shoreham - dd	-	1.96	0.76	27.6		
Bardon Hill - s	-	1.84	0.80	34.4		
Bardon Hill - ds	-	1.89	0.88	32.8		✓
Bardon Hill - dd	-	1.93	0.86	31.0		
Torr Works - s	-	1.79	0.82	34.8		✓
Torr Works - ds	-	1.85	0.91	32.9		
Torr Works - dd	-	1.86	0.92	32.5		
Average				33.95		
Standard deviation				2.83		

Notes

-	data not available	M	mass
s	single layer	V	volume
ds	double standard	✓	yes
dd	double dense	X	no

9.8.2 Checking packing density by panel surveys with block count method

The principle of the block count method (Latham *et al*, 2002) is simple. An area is marked out on a surface panel using stretched tapes and the area is calculated or is surveyed more accurately. A systematic method for counting all blocks deemed to be in the top layer of the area is adopted. The number per square metre or surface packing density should be reasonably constant if the material sizes and placement methods have not varied.

$$1 - n_v = Q' \frac{M_{em}}{M_{50}} \frac{1}{n k_t} \quad (9.7)$$

where n_v is the armour layer porosity (-), k_t is the layer thickness coefficient (-), n is the number of layers and Q' is the dimensionless packing density (defined in Equation 9.8) equivalent to the packing density coefficient, ϕ , used to measure the packing density of concrete armour units. For details on the ratio between the effective mean mass, M_{em} (kg), and the median mass, M_{50} (kg), see Section 3.4.3.8.

$$Q' = N D_{n50}^2 \quad (9.8)$$

where N is the number of block counts per unit area ($1/m^2$).

Equation 9.7 indicates that if the layer thickness coefficient, k_t (-), and the grading size and uniformity are constant from one area to another, then variations in Q' will indicate variations in porosity.

Using data for k_t values and effective mean masses, M_{em} , the void porosity in the armour layer of each panel can be predicted (see Latham *et al*, 2002). In practice, the k_t , M_{50} and M_{em}/M_{50} values in a panel are rarely measured, but, as a first approximation, the contract values can be substituted to enable the layer (or volumetric) porosity to be checked. In summary, the block count survey method proposed is a simple and quick method of checking workmanship and there is no reason why it could not be used in combination with good-quality photographs, for example as part of monitoring.

9.8.3 Quality control during construction

This section concerns quality control of materials on the construction site, including on temporary stockpiles, the means of transportation and even the finished works. These controls are part of the entire quality assurance process. Some general aspects of quality assurance are dealt with in Section 9.8.3.1. Section 9.8.3.2 deals with controls on the construction site and advantages and disadvantages when proceeding with such controls.

NOTE: The guidance given below refers in general only to situations where the EU Construction Products Directive (89/106/EEC) [2], as addressed in EN 13383 for armourstone, is not legally binding. Where the Directive applies, the producers of armourstone have to follow its legal requirements to issue CE marks indicating conformity of material delivered to the purchaser (see also Sections 3.7 and 3.10).

9.8.3.1 General aspects of quality assurance

Definitions related to quality assurance are formulated in international standards (BS 5750-1, ISO 9000 to 9004 and ISO 8402), from which some of the following have been extracted.

Quality The degree to which the product, process or services complies with the functional requirements.

Quality system	A documented set of activities, resources and procedures within the company organisation, serving to ensure that the product, process or service meets the quality requirement of the client.
Quality assurance (QA)	The process of implementation, maintenance, review and, where necessary, improvement of the <i>quality system</i> , including activities proving that the quality system meets the required standards.
Quality assurance manual	A document containing the description of the basic elements of the company's <i>quality system</i> .
Quality control	The total of all the specific operational practices, recourses and activities serving to maintain the required quality of a product, process or service.
Quality plan	A document describing the process of <i>quality control</i> relevant to a particular contract or project within the framework of the company, quality system (ie general and special procedures) and requirements.

A product of acceptable *quality* is a product that completely meets the requirements of the client. The realisation and delivery of quality products is the result of accurate control of all activities and concerns all parties involved, namely client, engineer and contractor, as becomes clear from the listed project stages below:

- market analyses and definition of existing needs
- definition and specification of functional requirements
- design process
- work preparation
- construction
- commissioning and testing
- maintenance
- evaluation after completion.

Quality assurance is not restricted to the construction stage, but involves all project stages. Consequently, the design should not only take into account functional requirements but should also be verified by checking practical construction requirements such as tolerances and construction feasibility using standard equipment.

The **quality plan** should include a description of the work methods and procedures to be applied. This should be completed during the preparation of the work, and construction should comply with the descriptions. The quality parameters of the construction activities such as the quarrying of core material and armourstone, transport, stockpiling, and placing into the works also have to be defined. Subsequently, it is necessary to decide how and to what extent these parameters can be controlled, ie work methods, or verified, ie survey and material tests.

Ideally, the contractor should allow the client the opportunity to review the project quality plan and, if necessary, it should be amended to reflect mutually agreed procedures before construction starts. In addition, performance of the works as a whole can benefit if the contractor and client can agree on procedures for the client to perform spot checks to verify that the works are progressing according to the **quality plan**.

Tests for **quality control** of materials in the quarry are discussed in Section 3.10, which presents standard procedures that are used to assess the quality of the placed armourstone. Some additional aspects related to the execution of a project are also discussed.

Selection of contractor

In selecting the contractor, the client should not only consider the price but also verify that the required quality can be met and assured. An important element is the (sub) contractor's **quality plan**, which should clearly indicate the organisation, responsibilities, work methods, planning and reporting system. It should also indicate how the quality of products is controlled within the contractor's organisation and, more importantly for the client, the contractor has to be able to show that the work meets the agreed requirements.

Organisation

Research has shown that difficulty in meeting quality standards is often an organisational, rather than technical, issue. The management organisation is of primary importance during all stages of the project, not just during construction. The specific tasks, responsibility and hierarchical position need to be documented for all those who have an influence on quality at the various project stages, such as the project manager and the quality manager.

At the construction stage, the contractor's company management should ensure that the **quality assurance policy** and objectives will be attained. A quality engineer should be appointed as part of the site team, who, in addition to other duties, should have the organisational freedom to:

- implement the **quality assurance** as presented in the **quality plan**
- identify and record quality problems
- initiate, recommend or provide solutions through designated channels
- verify implementation of solutions.

The quality engineer is charged with reporting to the management any failure to conform in terms of implementing the quality assurance and should keep the management advised of the status, implementation and adequacy of the **quality assurance system**.

The management is responsible for enforcing full implementation of the **quality assurance**. The position of the quality engineer in relation to the project management is illustrated in the organisation scheme set out in Figure 9.69.

Construction

During construction all procedures and work methods, as described in the **quality plan**, have to be executed. These should be standardised as much as possible. Section 9.1.1 gives an overview of items involved in the construction.

Tolerances

An important aspect of the quality is the definition of acceptable tolerances. One type of tolerance relates to size, eg of materials and structure elements. Equipment-related tolerances are discussed in Section 9.3.7.

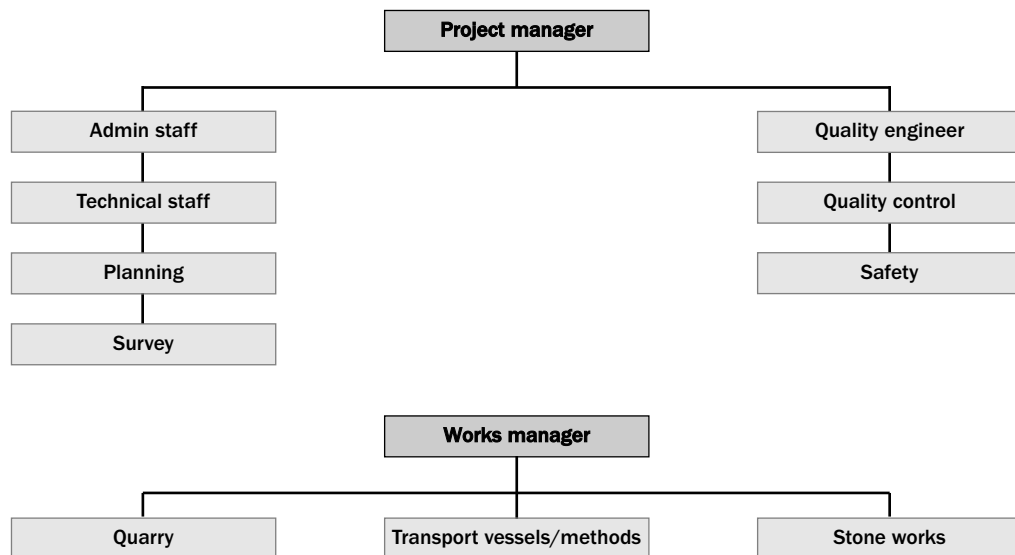

Figure 9.69 Example of site organisation

Another type of tolerance relates to the various activities within the time schedule of the project. Consider which time gaps and overlaps should be defined. The ideal situation is obtained when the design phase and the construction phase are smoothly linked to each other, resulting in a continuous process of exchange of experience, in which minor adjustments lead to final optimisation. The best set of tolerances emerges when continuous consultation takes place between designer, client and contractor.

From a construction point of view the feasibility of a design depends on the ability to realise the structure, preferably by using standard equipment. Site conditions, ie waves and currents, should also be taken into account.

To guarantee quality, the armourstone placement should be in accordance with standard procedures. In this respect, it is recommended that the grid system is presented on an electronic positioning tableau, mounted in the crane driver's cabin or on the bridge of a side stone-dumping vessel, displaying positions in three dimensions. Test panels should also verify the proposed construction method. Standard survey methods are presented in Sections 9.9 and 10.3. The survey frequency is closely related to the work method and should be included in the **quality plan**.

Designers should note that often it is advantageous not to be too specific simply because the technology exists. Specifications should be practical, sensible, achievable and affordable and suit the requirements of the works. It is important to determine whether the complexity of the projected work justifies excluding some contractors if they do not have the latest equipment. In some cases it could be more expensive to survey and work within very strict tolerances than to place additional materials, not taking into account environmental considerations.

9.8.3.2 **Quality control of materials on construction site**

If quality controls have been implemented at the quarry with good results, it should not be necessary to carry out additional verifications at the construction site. Unfortunately, the material that arrives at the construction site may be different from the material that has been ordered and it may also differ from the material that has been passed during the inspection at the quarry.

Reasons for this include:

- poor stone selection by quarry operators
- inaccurate mass estimation during loading, ie hand-picked loading
- introduction of quarry soil material while loading with a power shovel
- addition of smaller stones to reach the full load of a truck or a wagon
- wrong destination of trucks or other means of transport
- breakage during loading, transportation and unloading
- breakage during placement.

Although the first four items listed can be prevented by strict supervision of quality at the quarry, ie until the moment when the materials are loaded, the last three items cannot be verified before delivery.

It may be necessary to inspect the materials arriving at the construction site to compensate for poor-quality controls in the quarry and to take into account breakage during transportation, loading and unloading. Theoretically, the materials should be correctly produced and checked in the quarry, as any corrections are easier to carry out at this stage.

The following types of verification can be made on the construction site and in the quarry (see Sections 3.7 and 3.8 for a precise description of each method of verification):

- size and/or mass distribution
- shape and angularity
- origin of materials
- integrity
- micro-cracks by sonic velocity measurement.

These inspections can be made on temporary stockpiles, during transport on barge, vessel, truck or train or ultimately on the finished work.

If the client wishes to carry out quality controls on the construction site, this should be clearly stipulated in the contract between the client and the contractor. The following items should be stated in the contract:

- which party will pay for the verification tests
- frequency of the verification tests
- location of verification points
- sampling methods, eg one of the methods described in the EN 13383-2
- type of tests
- who supplies the facilities, equipment and/or workers required for the verifications.

Failure to meet the required standards will result in further corrective action taking place to ensure that the desired quality is achieved during further operations. Responsibility for delays associated with corrective action should be clearly defined in the contract. Reference can be made to EN 13383-2 to help in such a situation.

Random checking should be carried out.

For specific tests and/or to settle a disagreement, the producer, contractor or client may require assistance from an independent external laboratory. This requirement should be clearly stipulated in the contracts.

1

2

3

4

5

6

7

8

9

10

Advantages of implementing quality controls on the construction site

- implementing controls near to the construction site ensures that material complies with the required formats and leads to good-quality final work
- when two separate contracts are signed, one for supplying materials and one for placing materials, verification of the quality on the construction site helps to avoid discrepancies between the two contracts: quarry controls are stipulated in the contract between producer and contractor while on-site controls are stipulated in the contract between contractor and client.

NOTE: This is an advantage only if the on-site controls are referring to the same properties as the quarry controls. The quality of the armourstone is the responsibility of the producer and the final application of the materials is the responsibility of the contractor. In this arrangement, the overall responsibility of the quality of the works remains with the contractor.

Disadvantage of implementing quality controls on the construction site

One disadvantage of implementing quality controls on the construction site is the effect these procedures may have on the cost of the materials. Costs can increase for the following reasons:

- additional testing facilities will increase original costs
- well-planned tests on a construction site should not delay works if the results are good. In the case of poor test results, substantial delays may occur depending on the level of non-conformity. The contractor and/or producer should watch out for any risk of delay, as this will affect costs
- if some materials have to be returned because of non-conformity then the producer must bear the cost of the return trip. This risk will be integrated in the prices of materials.

Considering the above factors, the impact of on-site quality control procedures on both costs and scheduling is profound. For example, if armourstone is being sourced from Norway for a project on the French coastline then the implication of rejection on site is enormous. The regime for quality control throughout the supply chain should be considered by all parties and a system set up whereby possibilities of rejection on site are reduced to almost zero the closer the product is to incorporation in the work.

9.8.4 Test panel calculations and payment issues

The test panel is referred to in Appendix A1 Model construction specification. It is usually a 10 m length of a new section of a rock structure where the quality of placing of all layers – including the core, scour apron, underlayers, and armourstone or concrete cover layers – is demonstrated for approval by the engineer. Once approved, it provides the baseline for acceptable construction practice. This section addresses potential difficulties with armour layer quantities. To extract maximum benefit from the test panel exercise it is recommended that key measurements are made on the armour layer. This data can provide the calculation template for payment of materials once the panel is accepted as it then constitutes a small but well-quantified part of the works.

The test panel is an effective means of avoiding delays and disputes over acceptability of armour layer construction workmanship. Furthermore, it can be incorporated into the contract agreement as a basis for avoiding disputes over payment for materials.

It has been stressed that in the design process new guidance on layer thickness and as-placed density, especially of individually placed armour layers, as presented in Section 3.5.1, should be adopted in finalising design profiles. The mass of armourstone that the contractor has purchased and placed in the armour layer is then more likely to be close to the designer's estimate of required mass calculated from the design volume. The designer or client requires quality workmanship without liability for paying for fluids when rock was wanted, and without liability for paying for overly tight armourstone when less material was intended. The contractor wants speedy execution and full recouping of the cost outlay on materials. It is important to recognise a balance between the two parties' legitimate concerns. This requires that the designer's assumption for the armour layer porosity, n_v , applicable to the spherical probe survey method, is known, and that the validity of this assumption is checked during approval of the test panel.

It is recommended that the client declares in the contract:

- the payment rate for the mass of armourstone placed in each class of armourstone
- the assumed armour layer porosity, n_v , in each class of armourstone
- the assumed design layer thickness coefficient, k_t , for armour layers.

The test panel should form part of a larger completed section within realistic boundaries. Blocks falling on the boundaries of the panel are treated appropriately so as not to bias results. Particular care should be taken to ensure the test panel armourstone is representative of the specified grading. If necessary, adjustments to the trial panel are made until:

- grading is within specification
- final survey heights are within tolerance limits of the design drawing heights. Any serious difficulty in meeting these tolerances suggests that stone shape characteristics have not been accounted for and/or that inappropriate estimates of the k_t factor were assumed in the design. These problems can be resolved by rebuilding, resetting the design drawing surface levels or resetting tolerances
- in the eyes of the engineer, the visual appearance reflects the designer's intention as implied by the placement methods referred to in the contract and classified as random, standard, dense or specific.

This trial panel is then termed visually accepted and is subject to further analysis.

Given the placement method referred to in the contract on the one hand, and the blend of on-site factors (materials characteristics, placement machinery, operator training and experience, working conditions, time constraints) on the other, the trial panel exercise may point to a need to revise the most appropriate layer (or volumetric) porosity assumption for use in the payment calculation if payment is on a basis of armourstone tonnages deduced from surveyed volumes and target layer porosity.

Data obtained from the visually accepted test panel include:

- individual masses of all blocks in the panel. This provides further on-site control of heavy gradings. Individual weighing is preferred to the alternative of mass estimation from density and volume assessment using suitable block dimensions and shape factors. The total mass of armour in the panel is divided by apparent rock density, ρ_{app} (kg/m^3), to give the volume of armourstone in the panel, V_r (m^3)
- the surveyed armour layer volume, V_{bs} , corrected to spherical end $0.5D_{n50}$ probe method. The chainage length is multiplied by the average area enclosed between the upper and lower surveyed surface of the armour layer (see Equation 3.24, $V_{bs} = A_{cs}L$). Normally it should be sufficient to have four profile lines surveyed across the structure at 2.5 m intervals, making sure the end points of the survey line are included

- the number of blocks placed in the armour layer per unit of slope area covered. This should be presented both for the visible upper layer of blocks and for the total number of blocks.

Equation 9.9 gives the relation between the armour layer porosity (expressed as a fraction) of the visually accepted test panel and the relevant armour layer volumes.

$$n_{vp} = (1 - V_r / V_{bs}) \quad (9.9)$$

If there is less than a 2 per cent difference in value between n_{vp} and n_v assumed in the design (ideally also indicated in the contract), the panel is in every way acceptable as a construction benchmark to be followed for the contract.

If the difference is more than 2 per cent, another attempt might be made to construct nearer to the design armour layer porosity, without an unreasonably onerous burden being placed on the rate of build, given the classified placement method originally specified.

If after this rebuild the new surfaces surveyed fulfil tolerances and are visually accepted, but the test panel still has more than a 2 per cent difference, the contractor and engineer should agree that this panel becomes the benchmark for acceptable construction practices.

For those contracts where payment is based on a tonnage placed calculated from volume surveys, it is also an opportunity to validate and if necessary, revise the armour layer porosity assumption. If the contract states a pay rate for tonnage of armourstone placed in the works to be a tonnage calculated from surveyed bulk volume, assumed armour layer porosity and apparent rock density, then an appropriate basis for payment of the panel (see Equation 3.26: $V_r = V_b (1 - n_v)$) is given by Equation 9.10, an expression for the total mass of the armour, M_t .

$$M_t = \rho_{app} \cdot V_{bs} (1 - n_{vp}) \quad (9.10)$$

Placement workmanship at sample areas throughout the structure may be compared with the test panel(s) on visual criteria and also by comparing the number of blocks per unit area with results from the test panel(s). Major variations in block count results should be explained and removed by reworking if necessary. As the finished profiles of the entire works are normally checked for tolerances, the bulk-placed volumes of the entire armour layer in the completed structure can be similarly computed and bills for placed tonnages prepared accordingly. Precisely worded clauses usually exist to exclude liability for the client having to pay for armourstone determined by survey to be on average above an upper tolerance line.

Alternative simple schemes for payment based directly on tonnages placed exist. For example, contract payment for armour materials may be based on a rate per tonne delivered to site given satisfactory criteria for proof of delivery to site.

9.9 SURVEY AND MEASUREMENT TECHNIQUES

Because of the direct relationship between survey techniques and payments, all parties to a works contract should ensure that an accurate, fair and pragmatic approach to surveying is adopted that will lead to the correct method of payment for the work done. To suit the requirements of the works, tolerance levels should be practical, sensible, achievable and affordable. The various definitions of the term *tolerance* are set out in Section 9.3.7.

In addition to discussing the various survey techniques, this section also provides tables with information on achievable vertical tolerances for land-based and marine equipment, for both bulk and individually placed armourstone and concrete armour units.

9.9.1 Survey control

Construction is continually related to a nearby datum, control point or benchmark that co-ordinates with a local or national grid system. The client should provide the control points located in a safe position on stable ground close to the site. These should be checked regularly, particularly when long-term projects are involved. The control points should be protected from plant, and additional back-up or secondary benchmarks should be installed at the start of the project both to provide some redundancy in the survey system and to allow instrument set-up points to be established. Special care is required to ensure that no confusion occurs between the local reference level and chart datum.

When GPS is used for survey and setting out, a single base station location can usually cover the entire site. Ideally this should be within 3–4 km of the working area and should provide a radio line of sight for the entire project. Optical systems such as total stations require more control points that are more closely spaced, typically 500–600 m apart, with line of sight. Selection of the base station site is very important. When construction takes place on an embayment, the base station should ideally be located on an adjacent headland, providing line of sight across the water. The advantage of this is that a surveyor working on the lower section of a steep armour slope is less likely to lose the radio link than if the base station is located inland, with the armour face in radio shadow.

A series of intermediate control points should be established close to the working area and these should be examined regularly for damage throughout the project. Survey best-practice dictates that an initialisation and closing check on known points should be implemented on each survey. These intermediate checkpoints should be conveniently located to the structure and should be secure and safe from plant damage.

The most common method for surveying control points uses static GPS observations on a network of several control points, with simultaneous observations at remote co-ordinated sites. Typically, to achieve a high accuracy co-ordinate, these observations need to be of several hours' duration. Statistical analysis within the survey software indicates the accuracy achieved. Intermediate control points can be quickly established by using fast static or kinematic techniques. It is essential that the contractor and the client use the same control system.

9.9.2 Pre-construction survey drawings

Without adequate survey data it is difficult to set out a new structure. The designer should provide a detailed co-ordinated pre-construction illustration of the site that identifies irregular topographic features and any existing structures that must be removed. The construction drawings should identify all co-ordinates to be set out. In dynamic areas, such as beaches, it may be necessary to repeat this process immediately before construction starts. A digital XYZ survey is very valuable as it can be used to generate a ground model that can be integrated with the proposed construction geometry.

If the contractor is required to set out lines of 10 m apart, typical of many specifications, all necessary co-ordinate information should be made available at this stage. The contractor is required to build the structure to a defined crest and slope: the toe position can vary, according to levels at the toe. A common setting out problem is the determination of the excavation line for the toe of the structure in conditions where the bed topography is highly variable. This can be achieved by superimposing the co-ordinated construction drawing on the topographic survey. Ground modelling software can quickly provide the co-ordinate positions for the intercept of the toe of the structure and the existing topography; these positions can then be staked out using the survey system.

9.9.3 Alignment of structure

Kinematic GPS is the ideal way to establish alignment points on a structure. The accuracy provided lies well within that required for construction of armourstone structures. Kinematic GPS provides vertical accuracy of approximately ± 30 mm + 0.2 per cent of the baseline length. Plan position accuracy is often twice as good. Modern systems provide a stake-out mode by which the surveyor can navigate quickly to the plan positions of key change points to be marked on the ground. This is a simple process provided that both adequate survey data and a co-ordinated construction drawing, identifying all change points, are available in digital form.

9.9.4 Setting out of profiles

After the plan position of profiles has been established, with the aid of a co-ordinated survey system, the profiles of the structure can be set out. A range of techniques is available for this.

Levels or co-ordinated survey equipment can be used to fix batter rails to identify the construction slope. This is an awkward process, as it is often difficult to fix the rails in the armourstone on the slope, while the batter rail system needs to be large and is therefore unwieldy. Windy conditions often cause damage.

Rotating lasers improve the degree of control available during construction, as do the RTK (real-time kinematic) backpack and Pole systems (see also Section 9.9.8.2). Lasers emit an infrared beam that in some cases can damage the eye – warning signs illustrating potential eye damage should be displayed.

Ideally, lasers should be set up on reference points of a known height, Z m; the reference point to the beam level is measured at 1.5 m so that the laser is set up at $Z + 1.5$ m. If the top level of the armourstone is designed at $Z - 1$ m then the beeper can be put on the 2.5 m mark on the staff. The staff is moved up or down until the beeper sounds, indicating the required level and whether the armourstone in question falls within the required tolerance. This method can also be used for slopes by ensuring the designed slope is the same as that set for the laser; the beeper is set on the staff at the required height.

Most steep-slope lasers can be used on slopes up to 1:1 in both directions and at least 50 m in length and width. Advantages of dial gauge infrared lasers are that they:

- can be used at night (though not in strong winds or during fog, rain or snow)
- have a tolerance of ± 2 mm for short distances
- can be set up well away from where the plant is working, but may lose accuracy over greater distances
- are freely available from all hire shops
- are maintenance-free and come fully calibrated; calibration should always be checked.

9.9.5 Armour unit pattern placement

Armour units are normally pattern-placed to a predefined placing density and for this purpose a grid relative to a baseline can be set out. Co-ordinated placement of armour units is provided by computer-designed grid systems that are transferred to the placement plant, typically cranes.

Less sophisticated techniques include a layout alignment painted on the underlayer surface and operator controlled placement above water. More effective techniques above and below water level include crane-mounted electronic or mechanical positioning devices, the crane itself being positioned on a targeted location on land. Grid data must be available for the grid positioning of the crane and the angle position plus the distance from the crane to the cable.

Another technique used by land-based equipment and on barge-mounted cranes is to target the suspension cable with adapted land-based survey equipment. However, the most effective technique is a DGPS or GPS-RTK relative positioning system using a reference on land and another antenna on the boom end for a precise and quick target of the block positioning. The limitation of this technique is that the GPS antenna is placed above water and very often on the boom tip far from the actual location of the armour unit. Corrections and adapted quality control procedures must then be implemented to take into account the movement of both the barge and the armour units.

9.9.6 Roundhead setting out

The principles for setting out a roundhead are identical to those used for the trunk of the structure. The main difference is that the profiles are set out on a radius and at intervals different from those applicable to the trunk. As a basic rule, the roundhead should be set out to provide adequate spatial coverage at the toe to attain the roundhead plan shape. The geometry and stakeout co-ordinates should be extracted from adequately specified construction drawings. Special attention should be paid to setting-out the toe of the roundhead. The toe is generally more complex than the trunk because the roundhead crosses bed contours at a variety of angles and will be irregular. The idealised roundhead shown on many construction drawings can rarely be constructed at the toe because of topographic variability. Instead an irregular shape may result on the sea bed. The toe of the roundhead is often located below low water and it is necessary to make a detailed bathymetric survey to provide the geometric information required to ensure correct setting out of the toe with regard to both correct slope and crest geometry. Co-ordinated transition slopes on the approach to the roundhead should also be specified in detail by the designer, as abrupt changes of slope cannot be constructed properly.

9.9.7 Underwater construction

Underwater construction and setting out is less precise than that for the above-water section of a structure, although the same principles apply. Bathymetric surveys, combined with detailed construction drawings, are used to determine the required toe position. When armour is placed from the land, to ensure that it is located correctly it is necessary to use a co-ordinated placement system, ie a GPS antenna on the crane jib linked to a logger, or a co-ordinated crane grid placement system. Construction checks can be made by suspending a sounding rod from a crane fitted with either a GPS antenna or an electronic distance measurement (EDM) target (see Figure 9.70). Alternatively, regular bathymetric surveys can be conducted as the work progresses, although this may be hazardous in shallow water conditions.

1

2

3

4

5

6

7

8

9

10



Figure 9.70 Underwater profile checks with a sounding rod (courtesy David Bowie)

9.9.8 Survey techniques

9.9.8.1 Above water

Coarse and light armourstone gradings can be measured by using a probe with a spherical end of diameter $0.5D_{n50}$, which for a land-based survey will be connected to a staff, GPS antenna or EDM target. Measurements should be carried out at intervals of between 1 m and 2 m across the measurement profile.

Heavy gradings should be measured by means of a staff linked to a GPS antenna or EDM target probe, which for a land-based survey will generally be connected to a staff or EDM target. For individually placed double-layered systems of armour, three different survey methods can be used (see Figure 9.71):

- highest points
- spherical foot staff
- conventional staff.

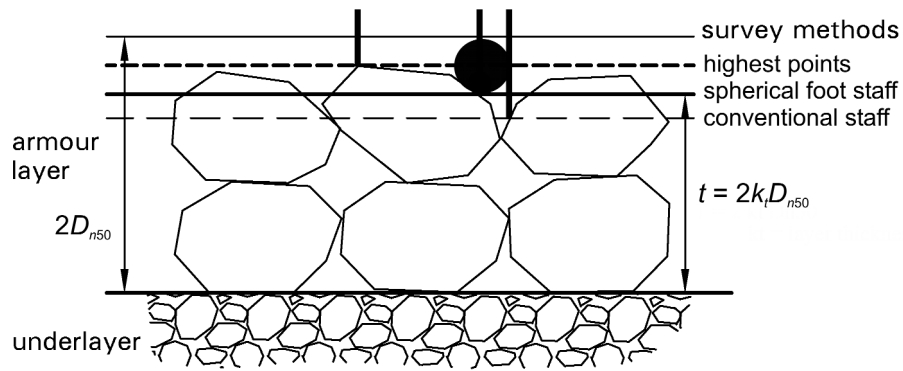

Figure 9.71 Effect of surveying methods on layer thickness for a double armour layer

Each method results in a different measurement of the layer thickness (see also Section 3.5). Research has established that the layer thickness coefficient, k_t (-), and the layer (or volumetric) porosity, n_v (-), depend on the planned shape and the placement method. Section 3.5 gives guidance results that are applicable for use of the reference surface survey method, ie spherical foot staff of $0.5 D_{n50}$. Some practical data (derived from prototype measurements) are provided in Box 9.3 (Section 9.8.1). In practice, health and safety concerns mean that surface surveys for trial panels and, for specification acceptance and payment line purposes, of heavy armourstone, are sometimes not performed with a spherical foot staff scaled to the armourstone sizes. Surveying with a conventional staff placed at recommended regular intervals generates a lower surface, which means that k_t and n_v values will need to be reduced according to a correction factor outlined in Table 9.9. By contrast, surveying by placing the staff on the highest point of every block that falls within a profile generates a higher profile and so also requires the use of a correction factor (also given in Table 9.9).

Table 9.9 Survey method correction factors derived for double layers (Latham et al, 2002)

Location	Highest point correction		Conventional staff correction	
	k_{thp}/k_t	n_{vhp}/n_v	k_{tcs}/k_t	n_{vcs}/n_v
Beesands $D_{n50} = 1.30$ m	1.082	1.176	0.929	0.838
Reculver $D_{n50} = 0.90$ m	1.045	1.110	0.904	0.785
Recommended factors	1.06	1.14	0.91	0.81

Notes

- k_{thp} = layer thickness coefficient obtained with conventional staff, highest point method (-)
- n_{vhp} = porosity obtained with conventional staff, highest point method (-)
- k_t = layer thickness coefficient obtained with spherical foot staff (-)
- n_v = porosity obtained with spherical foot staff (-)
- k_{tcs} = layer thickness coefficient obtained with conventional staff, regular intervals (-)
- n_{vcs} = porosity obtained with conventional staff, regular intervals (-)

Table 9.9 provides correction factors deduced from data obtained from two sites where three surface surveying methods were compared (Latham et al, 2002). The standard layer thickness coefficient, k_t (-), and volumetric porosity, n_v (-), based on surface surveys using $0.5 D_{n50}$ diameter foot can be converted to equivalent coefficients for highest point or conventional staff surveys. In practice, formation levels and final profiles are established with the survey techniques the contractor, in agreement with the engineer, deems the most appropriate of those available. Methods other than a staff with reflecting prism are equivalent to the highest point method.

Measurement profiles should be at intervals along the length of the structure, ie breakwater and seawall, as approved by the designer. These will generally be every 10 m, but may need to be more frequent where the profile is changing rapidly or on tight-radius curves. No layer should be covered by a subsequent layer until the client/designer has approved the profile of the former layer.

9.9.8.2

Under water

Available systems

Structural parts that are below the waterline can be surveyed by using a weighted ball on the end of a sounding chain. If they are too deep, surveys can only be completed by using echosounders or side-scan sonar.

Echosounders measure the water depth by determining the difference in time between the moment of sending the sound signal and the moment of receiving the signal after reflection from the sea bed. Using a preset value for the speed of sound under water, v_s (m/s), and the measured time interval, dt (s), the water depth, h (m), can be calculated as:

$$h = 0.5 v_s dt \quad (9.11)$$

There are two main echosounder systems:

- single-beam
- multi-beam.

Single-beam systems make use of one sound beam so that only the sea bed directly underneath the survey vessel is measured. The circular section of the sea bed measured is called the footprint (see Figure 9.72). The diameter of the footprint, D_f (m), depends on the beam angle, α (deg), and the water depth, h (m), according to Equation 9.12:

$$D_f = 2h \tan(0.5\alpha) \quad (9.12)$$

The beam angle (α) differs according to the system frequency but is in the range of 2.5–3.0°.

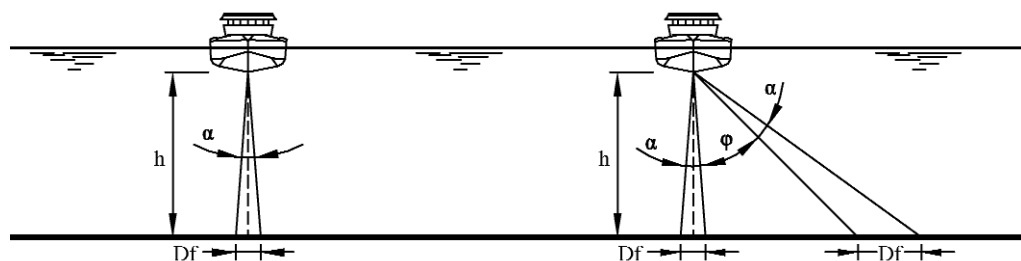

Figure 9.72 Footprint of single-beam and multi-beam echosounders (Rotterdam PWED et al, 2001)

Multi-beam systems use an array of sound beams allowing a line of points to be measured in one measurement sequence. This line of measurements is underneath and to both sides of the vessel but can be directed to one side if necessary (see Figure 9.72). The values of the sound/time measurements are calculated to depth values by the system software. This software is primarily designed for smooth surfaces. When rough or hard surfaces (ie those with bigger armourstones) are being measured, acoustic disturbances will occur, disrupting the processing of the sound beams. This can lead to systematic errors.

Multi-beam sound beams have a footprint that in many cases is smaller than that of single-beam systems. The beam angles, α , are in the order of 0.5–1.5°. Towards the sides the footprint increases when further away from the vessel (see Figure 9.72).

The diameter, D_f (m), of the oval-shaped footprint is given in Equation 9.13:

$$D_f = 2h \left[\tan(\varphi + 0.5\alpha) - \tan\varphi \right] \quad (9.13)$$

where φ is the direction of the beam relative to the vertical (deg) and h is the height difference between footprint and the ship's bottom (m).

In many systems φ can be varied in the range of -75° to $+75^\circ$ in steps of $\alpha = 0.5^\circ$ to 1.5° . The size of the footprint furthest away from the survey vessel might be five times the footprint underneath the vessel.

Sounding accuracy (Rotterdam PWED *et al*, 2001)

In view of the relationship between measurement and payment, it is clear that measurement inaccuracies have a significant effect. Background information regarding the origin of measurement inaccuracies of single-beam and multi-beam echosounding systems is essential. Measurements may contain two types of errors:

- systematic errors
- random errors.

A systematic error will result in all measurements being biased to one side, either too low or too high. Random errors will cause the measurements to vary within a certain bandwidth, the average level being equal to the true value. An example of a systematic error made when surveying rock works is that which emerges from the penetration of the measurement system into layers consisting of large stones. The average footprint levels will be lower than the top of the stones. This problem will not occur with coarse gradings, so a relationship exists between accuracy, armourstone grading and beam width.

The number of measurements per unit of area is also important. Using a levelling staff and sphere will provide only scattered spot measurements. Although a single-beam echosounder will deliver continuous profiles these are still separated by the distance between the survey lines. Measurements made with a multi-beam echosounder provide full coverage of the survey area.

Other influences on the accuracy of the measurements are:

- errors in the positioning of the survey vessel
- errors in the depth measurement (wrong speed of sound setting of the echosounder)
- poor or incomplete calibration of the system
- poor compensation of movement of the survey vessel
- inaccuracies arising from the system itself in relation to the measurement surface (smooth or rough, horizontal or sloping)
- the experience of the personnel.

These are mainly random errors and should not affect the average level.

Table 9.10 presents vertical accuracies of several survey systems in relation to the type of structure to be measured.

Table 9.10 Measurement accuracies (+/-) for the various echosounder systems (source Rotterdam PWED *et al*, 2001)

Bottom	Total station	Single-beam echosounder	Multi-beam echosounder	
			Centre beam	Outer beam
Sand	< 10 cm	< 10 cm	< 10 cm	< 10 cm
Filter layer	< 10 cm	< 20 cm	< 30 cm	< 20 cm
Top layer	< 30 cm	< 40 cm	< 40 cm	< 40 cm

Notes

- 1 The values for filter and top layer are only indicative and depend mainly on the relationship between footprint and stone diameter of the armourstone layer.
- 2 The finer accuracies achieved by the outer beam is the result of the bigger footprint since the smaller footprint of the centre beam will penetrate more into the measured layer.

At the time of writing, several satellite navigation systems are used for the horizontal location measurement, these being:

- global positioning system (GPS)
- differential global positioning system (DGPS)
- real-time kinematic (RTK).

The horizontal accuracies of these positioning systems are summarised in Table 9.11.

Table 9.11 Measurement accuracy (+/-) for various horizontal positioning systems (Rotterdam PWED *et al*, 2001)

System	Correction signal	Accuracy	
		1 σ value	2 σ value
GPS	-	< 5.00 m	< 10.00 m
DGPS	Commercially available	< 1.50 m	< 2.50 m
DGPS	Locally available	< 1.00 m	< 2.00 m
RTK	Locally available	< 0.05 m	< 0.10 m
Total station	-	< 0.01 m	< 0.02 m

Notes

- 1 Locally available means an additional own beacon is installed.
- 2 1 σ and 2 σ values mean: standard deviation with 65 per cent and 95 per cent confidence level.

The total accuracy of the vertical (z) and horizontal systems (x and y) can be summarised as follows:

- Type 1** DGPS + water measurement system (wms) – no test procedures protocol
x and y < 3.0 m; z < 0.40 m
- Type 2** DGPS + wms – using test procedures protocol and test references for x, y and z
x and y < 1.0/2.0 m; z < 0.10/0.20 m
- Type 3** RTK system – using test procedures protocol and test references for x, y and z
x and y < 0.50 m; z < 0.10 m

Little is known about the penetration of the footprint of the single- and multi-beam systems in armourstone layers of different gradings. Information on this aspect is important because it influences the establishment of the layer thickness. To gain more insight, tests with armourstone dumps of two gradings were carried out in the Verolme dry-dock in the Port of Rotterdam (Rotterdam PWED *et al*, 2001). The tests and the results are set out in Box 9.4.

The contractual risks of surveying

Large measurement differences may occur when an echosounder system is used for controlling rock works. It is in the interest of both the client and the contractor to understand these problems.

Systematic measurement errors may lead to large differences between the required levels or layer thickness and the as-built situation, which could result in non-acceptance of the part of the works concerned. Large random survey errors may also occur, eg when unsuitable placing tolerances are stipulated. This may also lead to non-acceptance.

The penetration of the signal from the echosounder into the armourstone layer will result in underestimation of the actual layer thickness. The measured layer thickness may vary between 0.25 and $0.75D_{n50}$.

The writer of the tender documents should be aware of the implications of the following:

- the measurement system to be used to check the works
- the way the measurements are carried out
- the demands placed on the results of the measurements
- the consequences for the client and/or contractor when the demands are not met
- the definition of the placing and measurement tolerances used in the tender documents.

In practice, measurement of the armourstone quantity placed in tonnes is the only hard evidence that reflects the quality of the works. To protect the contractor against large systematic errors, it is preferable to use the combination of quantity placed per area in combination with echosounder measurements.

It is important that the client, designer and contractor all use the same definitions, particularly with respect to the precise definition of what is being measured. For example, which of the following should be used:

- spot measurements or the measurement of an area?
- the accuracy of one value or the average of a number of values with a corresponding standard deviation?
- the standard deviation of several measurements in one area or the standard deviation of several averages of several measurement areas?
- the level of the tops of armourstone or the level defined by a theoretical design line as measured by a predetermined measurement system?

It is imperative that all parties to the contract use the same definitions.

1

2

3

4

5

6

7

8

9

10

Box 9.4 *Practical experience of measurements with single- and multi-beam echosounders (Rotterdam PWED et al, 2001)*

As described, the footprint of the single- or multi-beam system is vital for the penetration into the armourstone layer. When the stones are small enough to fall within the footprint of the beam, the tops of the stones will be measured. When the stones are bigger than the footprint, the beam can penetrate into the armourstone layer, resulting in lower-level readings. The situation for a multi-beam system is more complicated because it is not known how the extra reflection from the rough armourstone layer surface influences the behaviour of the bundles and beams.

A series of tests was carried out inside a dry-dock. Two armourstone layers were placed, with grading 10–60 kg and 40–200 kg respectively. Both layers had a thickness of $2.5 D_{n50}$ and one side of each section consisted of a sloping face.

The following measurements were taken:

- measurement with staff and level instrument, ie dock dry
- measurement with staff with a semi-spherical probe equal to $0.5 D_{n50}$ at the end and level instrument, ie dock dry
- single-beam echosounders, dock submerged, 10 m water depth, beam angles 2.5° and 2.7° , giving a footprint of $1.25\text{--}1.9 D_{n50}$
- four systems of multi-beam echosounders, dock submerged, 10 m water depth, bundle angle 1.5° , giving a footprint of $0.7\text{--}1.1 D_{n50}$.

In conclusion some of the measurements were:

- the semi-spherical head (half ball) gave the highest levels: only slightly below the tops of the stones
- the single-beam system varied little from the semi-spherical (see Section 9.9.8.1) probe measurements: 1 per cent for the average layer thickness of the 10–60 kg grading and 5 per cent for the 40–200 kg grading – the diameter of the footprint must be minimum 3 to $5 D_{n50}$ in order to measure the tops of the stones
- the measurements with the multi-beam system demonstrated the smallest layer thicknesses.

The differences in layer thickness for various systems compared with the semi-spherical probe system are given in Table 9.12.

Table 9.12 *Layer thicknesses measured by levelling staff, single-beam and multi-beam systems compared with semi-spherical probe survey system*

Grading	Measurement system		
	Single-beam	Levelling staff	Multi-beam
10–60 kg	- 3%	- 14%	- 21% ($\cong 0.61 \cdot D_{n50}$)
40–200 kg	- 5%	- 8%	- 11% ($\cong 0.32 \cdot D_{n50}$)

Note

The standard deviation of the beams for the multi-beam echosounder varies with the location of the beam and is highest underneath the boat (7 cm) and lowest towards both sides (3.5 cm). Because of the difference of penetration into the armourstone layer the survey should be carried out with an overlap of 50–100 per cent, so that the measurements will be a mix of centre and outer beam values.

9.10 REFERENCES

- Caquel, F, Claire, J, Fauvre, Y H and Olivier, F (1999). "Behaviour of filtration geotextiles subjected to falling blocks" ("Comportement des géotextiles de filtration soumis à des chutes de blocs"). In: H Girard and J P Courc (eds), *Proc 4th French conf recontres géosynthétique, Bordeaux, Oct 1999*, vol 2, pp 279–286 (in French and English)
- CERC (1984). *Shore protection manual [SPM]*. Coastal Engineering Research Center (CERC), US Army Corps of Engineers, Vicksburg, MS
- Chew, S H, Karunaratne, G P, Tan, S A and Wong W K (1999). "Standardized Drop Test (SDT) to evaluate the puncture resistance of geotextiles in coastal revetments" ("Essai d'impact standard (EIS) pour évaluer la résistance au poinçonnement des géotextiles en protection des berges cotières"). In: H Girard and J P Courc (eds), *Proc 4th French conf recontres géosynthétique, Bordeaux, Oct 1999*, vol 2, pp 303–310 (in French and English)
- Cruickshank, I and Cork, S (2005). *Construction health and safety in coastal and maritime engineering*. Thomas Telford, London
- CROW (1999). *Construction and measurement tolerances in marine construction*. CROW workgroup
- Delft Hydraulics (1989). *Investigation on the dumping result of a side stone dumping vessel, model tests, Part I and II* (in Dutch). Report Q 673, Delft Hydraulics, Delft
- Godfrey, P S (1996). *Control of risk. A guide to the systematic management of risk from construction*. SPI25, CIRIA, London
- Humphreys, B, Coates, T, Watkiss, M and Harrison, D (1996). *Beach recharge materials – demand and resources*. Report 154, CIRIA, London
- Latham, J P, Newberry, S, Mannion, M, Simm, J D and Stewart, T (2002). "The void porosity of rock armour in coastal structures". *ICE water and maritime engineering*, vol 154, no 3, pp 189–198
- Morris, M W and Simm, J D (2000). *Construction risk in river and estuary engineering: a guidance manual*. HR Wallingford, Wallingford
- Rotterdam Public Works Engineering Department, Port of Rotterdam, VBKO and IADC (2001). *Construction and survey accuracies for the execution of dredging and stone dumping works* (in Dutch). Rotterdam
- Schiereck, G J (2001). *Introduction to bed, bank and shore protection – engineering the interface of soil and water*. Delft University Press (ISBN 90-407-1683-8)
- Simm, J D and Cruickshank, I (1998). *Construction risk in coastal engineering*. Thomas Telford, London
- USACE (2003). *Coastal engineering manual [CEM] Engineer Manual 1110-2-1100*, US Army Corps of Engineers, CHL-ERDC, WES, Vicksburg, MS
- Vrijling, J K (2001). "Probabilistic design of water defence systems". *The Netherlands reliability engineering and system safety*, vol 74, no 3, Dec 2001, pp 337–344
- Wegner, B C (2004). "Large jetty construction challenges: Yaquina North Jetty, Oregon". In: J A Melby (ed), *Proc 4th int coastal structures conf, Portland, OR, 26–30 Aug 2003*. ASCE, Reston, VA