

RUBBLE MOUND BREAKWATER FAILURE MODES

Hans F. Burcharth¹ Zhou Liu²

ABSTRACT

The RMBFM-Project (Rubble Mound Breakwater Failure Modes) is sponsored by the Directorate General XII of the Commission of the European Communities under the Contract MAS-CT92-0042, with the objective of contributing to the development of rational methods for the design of rubble mound breakwaters.

11 institutes from the European Union participate in the project. The paper presents an overview of the project background, the research objective, the research methodology and the research results of the project. The outcome of the project is a large amount of formulae describing important failure modes, plus development of related partial coefficients which make it possible to design according to preselected reliability levels. Due to limited space only the major activities are described.

1. INTRODUCTION

The failure modes of a rubble mound breakwater are indicated in Fig.1. It should be stressed that these failure modes interact with each other, e.g. the erosion of the toe berm and the breakage of armour units will speed up the erosion of the armour layer, and excessive overtopping might cause failure of the rear slope.

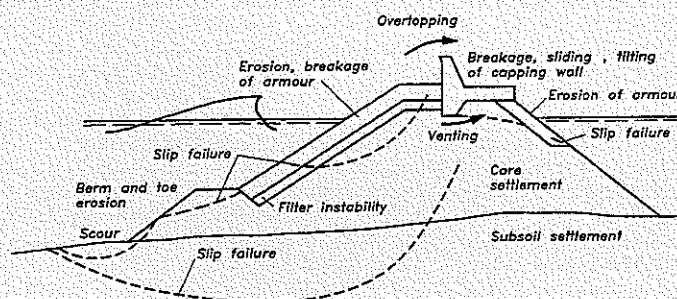

Fig.1. Failure modes of a rubble mound breakwater (Burcharth, 1993).

The RMBFM-Project (Rubble Mound Breakwater Failure Modes) is sponsored by the Directorate General XII of the Commission of the European Communities under the Contract MAS-CT92-0042, with the objective of contributing to the development of rational methods for the design of rubble mound breakwaters.

The project was structured in three main tasks:

- Task I Structural integrity of concrete armour units
- Task II Displacement failure modes
- Task III Design guidelines

¹Professor, dr.techn., Department of Civil Engineering, Aalborg University, Denmark

²Assistant Professor, Ph.D., Department of Civil Engineering, Aalborg University, Denmark

Tasks I and II contained 14 subtasks all dealing with research related to failure modes which had to be investigated in order to establish the necessary background for completion of Task III which forms the synthesis of the project.

In the project participate 11 institutes from Denmark, Germany, Italy, Spain, the Netherlands, the United Kingdom and France. The coordinator of the project is Aalborg University, Denmark.

The project was started on January 1, 1993 and terminated on December 31, 1995. All research activities were completed according to the schedule. All tasks defined within the project have been fulfilled.

In total 6 workshops were held. More detailed scientific results are given in the proceedings of the workshops.

Workshop	Place	Date
start-up	Copenhagen, Denmark	22 June 1993
Scour	Copenhagen, Denmark	21 June 1993
2nd	Bressanone, Italy	20-21 January 1994
3rd	De Voorst, Holland	15-16 December 1994
4th	Aalborg, Denmark	8-9 June 1995
final	Sorrento, Italy	11 November 1995

In the following is presented an overview of the project background, the research objective, the research methodology and the results of the project according to the order of the task structure. Due to limited space only the major activities are described.

2 Structural integrity of concrete armour units and hydraulic stability of armour layers

Wave induced stresses and hydraulic stability of Dolosse and Tetrapods

Many of the recent dramatic failures of a number of large rubble mound breakwaters armoured with Dolosse and Tetrapods were caused by breakage of the units. Breakage took place before the hydraulic stability of intact units in the armour layers expired. Thus there was an imbalance between the strength (structural integrity) of the units and the hydraulic stability (resistance to displacements) of the armour layer.

Due to the stochastic nature of the wave loads, the complex shape of the armour units and their random placement, the problem cannot be dealt with on a deterministic basis, but must be handled as a probabilistic problem.

Consequently, a very large number of situations must be investigated. This can be performed at reasonable costs only by small scale experiments. On this background it was decided in the present project to study stresses in small scale armour units by the use of very sensitive strain gauge load-cells inserted in the units. Fig.2 shows the 200 g Dolos and 280 g Tetrapod with the load-cells which were developed and

kindly lent to the project by CERC, Vicksburg, USA.

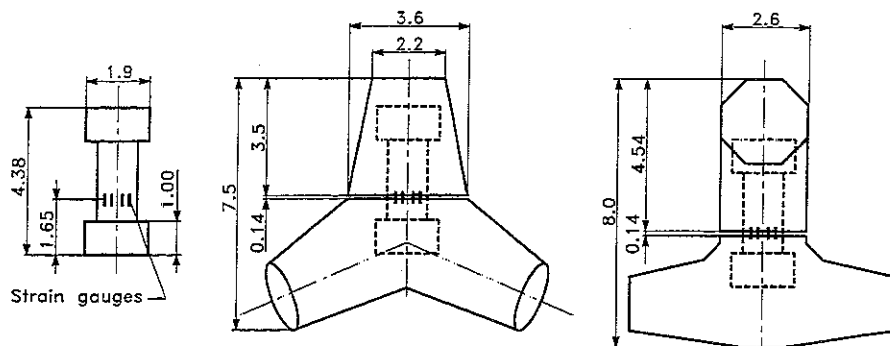

Measuring channels: Two orthogonal bending moments
Torque

Measures in cm

Fig. 2. 200 g Dolos and 280 g Tetrapod with the load-cells.

Static, quasi-static and solid-body impact loads and stresses have been studied as function of the wave action. The small scale instrumented units have been calibrated against the prototype units in order to scale up the model test results to prototype scales. Design diagrams have been produced which, for the first time, makes it possible to design the units as a structural member strong enough to avoid excessive breakage.

The hydraulic stability of Dolos and Tetrapod armour layer were studied by photo and video techniques in the model tests. The displacements were visually registered.

The main conclusions from the model tests are

- Dolos armour layer in a breakwater with a high superstructure is more vulnerable than that in a breakwater with none or a low superstructure, both with respect to hydraulic stability and structural integrity. The hydraulic stability design formula, which was developed before for non-superstructure and non-overtopping breakwaters has been modified into

$$N_s = \frac{H_s}{\Delta D_n} = A (43 - 66 r) \varphi_{n=2} D^{1/3} N_z^{-0.1}$$

where A follows the normal distribution $N(1, 0.20)$.

- Design formula for prediction of the number of Dolosse which will break in trunks

$$B = A C_0 M^{C_1} S^{C_2} H_s^{C_3}$$

Fitted parameters

waist ratio	C_0	C_1	C_2	C_3	σ_A
0.325	0.00973	-0.749	-2.584	4.143	0.188
0.37	0.00546	-0.782	-1.221	3.147	0.200
0.42	0.01306	-0.507	-1.743	2.871	0.176

- The stability of Dolos armour improves significantly (up to 50 %) if the Dolosse are placed in pattern instead of randomly placed.
- Dolosse in the round-head are less stable than those in the trunk. Design formula for prediction of number of Dolosse in round-heads

$$B = A C_0 M^{C_1} S^{C_2} H_s^{C_3}$$

Fitted parameters

waist ratio	C_0	C_1	C_2	C_3	σ_A
0.37	0.025	-0.65	-0.66	2.42	0.075

- The model tests have been carried out on the hydraulic stability of pattern placed single layer Dolosse. A significant increase in the hydraulic stability was observed.

- Wave run-up on Dolosse slope: $\frac{R_{u,2\%}}{H_s} = A (0.75 + 0.11\xi_p)$

where A follows the normal distribution $N(1, 0.10)$

- In cases where the waves are depth limited, the hydraulic stability of the Tetrapods armour will be underestimated by the formula previously developed by Van der Meer for deep water structures. A new design formula is proposed.
- Design formulae for the calculation of the number of broken Tetrapods

$$B = A C_0 M^{C_1} S^{C_2} H_s^{C_3}$$

Fitted parameters

C_0	C_1	C_2	C_3	σ_A
0.00392	-0.79	-2.73	3.84	0.24

Hydraulic stability of hollowed Antifer blocks and hollowed cubes

Besides stresses caused by mechanical and hydraulic loads, another problem related to the structural integrity of concrete armour units is the thermal stress. Cracking takes place due to the temperature differences created by the hydration process during curing. The related tensile stresses increase with the thickness of the units and can easily exceed the very limited strength of the fresh young concrete, thus causing formation of microcracks. In order to reduce the problem some new types of bulky concrete armour units, where a hole has been introduced, have been investigated with respect to both the hydraulic stability and thermal stresses.

The hydraulic stability of hollowed cubes and hollowed Antifer blocks was studied comparatively in 2-dimensional model test and in round-head tests. Wave run-up on the slope was also measured. The main results and conclusions from the test are

- The stability of the hollowed cubes seems better than the hollowed Antifer blocks for the slope 1:1.5, but opposite for slope 1:2.

- When a superstructure is introduced the stability decreases for the slope 1:1.5, but increases for the slope 1:2.
- With respect to the general effect of slope angle on the stability the tests showed that the armour layer of slope 1:1.5 is more stable than that of 1:2 for both types of blocks.
- Wave run-up on hollowed cubes and hollowed Antifer blocks

$$\frac{R_{u,2\%}}{H_s} = A (0.78 + 0.17\xi_p)$$

where A follows the normal distribution $N(1, 0.213)$

- Trunk stability of hollowed cubes and hollowed Antifer blocks

$$N_s = A \xi_p^{-0.1} (3.3 + 0.7N_0^{0.4})$$

where A follows the normal distribution $N(1, 0.35)$ and N_0 is the number of blocks displaced within a strip of width D_n

- Round-head stability of hollowed cubes and hollowed Antifer blocks

$$N_s = A (1.8 + 6.6D^{0.33} \xi_p^{-0.1})$$

where A follows the normal distribution $N(1, 0.15)$ and D is the relative displacement of blocks.

Thermal stresses in Tetrapods and hollowed cubes

The weakening of the concrete units by crack formation due to stresses caused by temperature difference was studied using numerical models. Thermal stresses inside Tetrapods and hollowed cubes during the hydration process were calculated by FEM technique based on both potential flow analysis and flow-stress analysis. The results show

- Micro cracks and related weakening of the concrete occur inside Tetrapods and cubes during the hydration process when conventional concrete mixes and casting procedure are applied.
- Introduction of a hole in the cube reduces significantly the thermal stresses generated during the hydration process and the block weight is over 10 t. Optimization of the diameter of the hole in order to reach a balance between the influence of thermal stresses and the strength of the cube can now be performed.
- The measures for the reduction of the damaging temperature differences and the related tensile stress during hydration process are: use of lower mix temperature and lower cement content, use of retarder and insulation of the units. These measures can now be quantified and optimized.

FEM has also been used to evaluate the stress field in Tetrapods caused by the solar radiation in the in-situ prototype Tetrapods. The results show that the maximum

tensile stress in some part of 10 t Tetrapods under air temperature of 30°C reaches 3 Mpa, which is about the tensile strength of normal plain concrete. Together with the field investigations it is concluded that the solar heating of armour units contributes to the observed deterioration of the concrete.

FEM has also been applied to determine the stresses in Tetrapods under static loading conditions. The concrete is assumed isotropic and elastic. Three types of load have been considered, namely self weight, horizontal wave pressure and horizontal contact force. The results are summarized in formulae for calculation of the maximum compressive and tensile stresses, given the Tetrapod size and types of loadings.

Fatigue and prototype concrete strength

Fatigue of concrete structures should always be considered when repeated stress variations are significant, because concrete shows significant fatigue. The waves will cause pulsating and impact forces on the armour units and thus significant stress variations. Considering the high stress level in the large slender type of units such as Dolosse and Tetrapods it is therefore important to evaluate the fatigue effect. Literature study was performed on the fatigue effect of concrete in general and of armour units in particular. The collected information includes research results on the fatigue under *static+pulsating* and *impact* loading conditions. Fatigue tests have been performed to quantify the effect of loading frequency on the fatigue life of plain concrete in tension. Several fatigue models have been used for the fatigue calculation under estimated typical life time load conditions. The conclusion obtained so far is that only if the prototype concrete quality is good (say a tensile strength $\geq 3 \text{ MPa}$), and the armour layer is designed for marginal displacement, then the fatigue effect is not critical. In order to obtain more realistic fatigue evaluations, the real loading conditions must be determined from some prototype sites.

Due to the importance and lack of knowledge of the strength of prototype concrete units, a concrete property investigation of the prototype units was added as additional work specified in the Technical Annex for Additional Work. UR has performed the analysis on 15 t Tetrapods cast in 1975 at Cagliari Industrial Harbour, and on 15 t Tetrapods and 30 t Dolosse cast in 1979 at Gioia Tauro Industrial Harbour. Some of the units were removed from the armour, and cores were drilled in the yard. For some other units cores were drilled from units still in place in the armour. A special drilling machine was used. Core sample testing shows rather good quality of concrete. After 15 year service the average tensile strength is about 4 MPa, higher than the originally specified value. The results indicate that the weakest point in Tetrapods is near the triple leg intersection and in Dolosse at the mid position of the trunk. UR has further carried out analysis of the cores taken from 24 year old 15 t Tetrapods lifted from the round-head of the south jetty at Chioggia inlet (Venice lagoon). The results confirm the good performance of this aged marine concrete, which achieves a mean tensile strength above 4 MPa and a compressive strength of about 60 Mpa, with the coefficient of variation of 0.2 and 0.25 respectively. The results reveal also that there is no apparent strength difference between the emerged and submerged units.

3 Displacement failure mode interaction

As mentioned before, various failure modes of a rubble mound breakwater will interact with each other, e.g. the erosion of the toe berm will speed up the erosion of the armour layer. Failure mode interaction must be investigated in order to evaluate the overall failure probability of the structure. Due to the complexity of the problem it was decided to focus on the interaction of the displacement failures of the different parts of the structure, i.e. sea bed, toe berm, main armour, superstructure, rear slope.

Before the start-up of the model tests, investigation has been carried out on a theoretical probabilistic model for the determination of failure mode interactions. The model is formulated for toe berm - main armour failure interaction, but can be applied to other failure mode interactions. The model is based on the assumption that the failure of the armour is affected by the failure of the toe if the toe is damaged to a certain degree.

A large amount of previous tests has also been reviewed in order to explore the phenomenon of failure mode interaction. The review shows that without a toe structure the armour layer stability decreases evidently. Moreover, the stability of the rear slope influences the stability of the superstructure significantly.

Toe berm stability

The prerequisite for failure mode interaction studies is that each single failure mode is well described. Because this was not the case for toe berm stability, a parametric study of rock toe berm stability was performed and a stability formula was presented. The test results reveal that the width of berm and the wave period have very little influence on stability. The formula was modified in order to include toe berms made of concrete cubes. The modified formula reads

$$N_s = \frac{H_s}{\Delta D_{n50}} = A \frac{1.6}{N_{od}^{-0.15} - 0.4 \frac{h_t}{H_s}}$$

where A follows the normal distribution $N(1, 0.125)$, h_t is the water depth over the toe berm and N_{od} is the number of the displaced units within a strip width of D_{n50} .

Sea bed erosion

The erosion of sea bed in front of coastal structures might cause damage to the toe berm and was investigated by hydraulic model tests. The investigation includes four parts: flow-visualization, bed shear stress recording, particle tracking and actual scour measurement. A one-component Laser Doppler Anemometer and a two-component hot-film probe were used to measure the flow velocity and the bed shear stress respectively. The scour process around the structures were videotaped, using a underwater mini video camera. The results indicated that, around the head of the rubble mound breakwater, there exists a scour/deposition process induced by the wave generated streaming phenomenon and wave breaking. The scour is much less significant than in the case of a round-head of a vertical wall breakwater. The test results are in good agreement with the field measurement performed by the U.S. Army Corps of Engineers.

$$\text{Steady stream scour depth: } \frac{s}{B} = 0.04 A \left(1 - \frac{1}{e^{4(KC-0.05)}} \right) \quad KC = \frac{U_m T}{B}$$

tensile stress in some part of 10 t Tetrapods under air temperature of 30°C reaches 3 Mpa, which is about the tensile strength of normal plain concrete. Together with the field investigations it is concluded that the solar heating of armour units contributes to the observed deterioration of the concrete.

FEM has also been applied to determine the stresses in Tetrapods under static loading conditions. The concrete is assumed isotropic and elastic. Three types of load have been considered, namely self weight, horizontal wave pressure and horizontal contact force. The results are summarized in formulae for calculation of the maximum compressive and tensile stresses, given the Tetrapod size and types of loadings.

Fatigue and prototype concrete strength

Fatigue of concrete structures should always be considered when repeated stress variations are significant, because concrete shows significant fatigue. The waves will cause pulsating and impact forces on the armour units and thus significant stress variations. Considering the high stress level in the large slender type of units such as Dolosse and Tetrapods it is therefore important to evaluate the fatigue effect. Literature study was performed on the fatigue effect of concrete in general and of armour units in particular. The collected information includes research results on the fatigue under *static+pulsating* and *impact* loading conditions. Fatigue tests have been performed to quantify the effect of loading frequency on the fatigue life of plain concrete in tension. Several fatigue models have been used for the fatigue calculation under estimated typical life time load conditions. The conclusion obtained so far is that only if the prototype concrete quality is good (say a tensile strength $\geq 3 \text{ MPa}$), and the armour layer is designed for marginal displacement, then the fatigue effect is not critical. In order to obtain more realistic fatigue evaluations, the real loading conditions must be determined from some prototype sites.

Due to the importance and lack of knowledge of the strength of prototype concrete units, a concrete property investigation of the prototype units was added as additional work specified in the Technical Annex for Additional Work. UR has performed the analysis on 15 t Tetrapods cast in 1975 at Cagliari Industrial Harbour, and on 15 t Tetrapods and 30 t Dolosse cast in 1979 at Gioia Tauro Industrial Harbour. Some of the units were removed from the armour, and cores were drilled in the yard. For some other units cores were drilled from units still in place in the armour. A special drilling machine was used. Core sample testing shows rather good quality of concrete. After 15 year service the average tensile strength is about 4 MPa, higher than the originally specified value. The results indicate that the weakest point in Tetrapods is near the triple leg intersection and in Dolosse at the mid position of the trunk. UR has further carried out analysis of the cores taken from 24 year old 15 t Tetrapods lifted from the round-head of the south jetty at Chioggia inlet (Venice lagoon). The results confirm the good performance of this aged marine concrete, which achieves a mean tensile strength above 4 MPa and a compressive strength of about 60 Mpa, with the coefficient of variation of 0.2 and 0.25 respectively. The results reveal also that there is no apparent strength difference between the emerged and submerged units.

3 Displacement failure mode interaction

As mentioned before, various failure modes of a rubble mound breakwater will interact with each other, e.g. the erosion of the toe berm will speed up the erosion of the armour layer. Failure mode interaction must be investigated in order to evaluate the overall failure probability of the structure. Due to the complexity of the problem it was decided to focus on the interaction of the displacement failures of the different parts of the structure, i.e. sea bed, toe berm, main armour, superstructure, rear slope.

Before the start-up of the model tests, investigation has been carried out on a theoretical probabilistic model for the determination of failure mode interactions. The model is formulated for toe berm - main armour failure interaction, but can be applied to other failure mode interactions. The model is based on the assumption that the failure of the armour is affected by the failure of the toe if the toe is damaged to a certain degree.

A large amount of previous tests has also been reviewed in order to explore the phenomenon of failure mode interaction. The review shows that without a toe structure the armour layer stability decreases evidently. Moreover, the stability of the rear slope influences the stability of the superstructure significantly.

Toe berm stability

The prerequisite for failure mode interaction studies is that each single failure mode is well described. Because this was not the case for toe berm stability, a parametric study of rock toe berm stability was performed and a stability formula was presented. The test results reveal that the width of berm and the wave period have very little influence on stability. The formula was modified in order to include toe berms made of concrete cubes. The modified formula reads

$$N_s = \frac{H_s}{\Delta D_{n50}} = A \frac{1.6}{N_{od}^{-0.15} - 0.4 \frac{h_t}{H_s}}$$

where A follows the normal distribution $N(1, 0.125)$, h_t is the water depth over the toe berm and N_{od} is the number of the displaced units within a strip width of D_{n50} .

Sea bed erosion

The erosion of sea bed in front of coastal structures might cause damage to the toe berm and was investigated by hydraulic model tests. The investigation includes four parts: flow-visualization, bed shear stress recording, particle tracking and actual scour measurement. A one-component Laser Doppler Anemometer and a two-component hot-film probe were used to measure the flow velocity and the bed shear stress respectively. The scour process around the structures were videotaped, using a underwater mini video camera. The results indicated that, around the head of the rubble mound breakwater, there exists a scour/deposition process induced by the wave generated streaming phenomenon and wave breaking. The scour is much less significant than in the case of a round-head of a vertical wall breakwater. The test results are in good agreement with the field measurement performed by the U.S. Army Corps of Engineers.

$$\text{Steady stream scour depth: } \frac{s}{B} = 0.04 A \left(1 - \frac{1}{e^{A(KC-0.05)}} \right) \quad KC = \frac{U_m T}{B}$$

Wave breaking scour depth: $\frac{S}{H_s} = 0.01 A \left(\frac{T\sqrt{gH_s}}{h} \right)^{1.5}$

where S is the scour depth, B the bottom width, T the wave period, h the water depth and A is the uncertainty of the formulae which follows normal distribution $N(1,0.2)$.

Numerical modelling of scour in front of coastal structures was studied by DHI. DHI applied a linear wave model, coupled with a sediment transport model (including both bed load and suspended load) in order to obtain prediction of the morphological changes in front of partially reflecting structures exposed to head-on regular wave attacks.

Interaction between toe berm and main armour stability

Two-dimensional hydraulic model tests have been carried out in order to quantify the effect of the toe berm conditions on the stability of main armour. The damage on the main armour layer and the toe berm under increasing wave heights were monitored by profiling after each wave attack and counting the number of stones displaced from the armour layer and the berm. The test results showed that moderate damage of the berm has almost no influence on armour layer stability, whereas high damage of the berm reduces the armour layer stability severely. Therefore in practice it is economical to design a berm for moderate damage.

The reliability analysis was performed on the main armour and toe berm interaction based on the experimental data. The analysis of the data showed that the toe berm stability increases due to the armouring effect of the stones displaced from the main armour. Taking into account this protection effect, a formula describing the toe berm stability has been proposed. However, the influence of the toe berm damage on the main armour stability cannot be formulated because the data have no clear tendency. If it is assumed that the damage of the main armour is not influenced by the toe berm, the reliability calculations indicate that the interaction effect is negligible.

As an extension of the 2-D test on toe berm - main armour failure interaction, 3-D tests have also been performed. The model consisted of both trunk and round-head sections. 2-D and 3-D waves with perpendicular and oblique angles of wave attack were applied. The test set-up and test procedure were rather similar to the 2-D tests. Due to the limited knowledge on the stability of armour and the berm at the round-head, some preliminary tests were carried out in order to identify the right stone size to be used in the tests. The damage was evaluated by counting the number of units displaced from the main armour and the toe berm. It appears that as expected the major feature of the interaction process between main armour and toe berm is an increase of armour damage caused by unstable toe berm. The test results of the armour and toe berm stability were fitted to the well-known formulae (Hudson and van der Meer) and thus the uncertainties of these formulae have been obtained.

Interaction between wave wall and main armour

A numerical model has been developed for the dynamic response of a superstruc-

ture. The model is based on a series assumptions, e.g. rigid superstructure and linear elastic and homogeneous soil. The results are presented in the diagrammes which provide the ratio of the maximum dynamic deflection/rotation to the maximum static deflection/rotation as functions of the wave load rising time and the natural frequency of the superstructure. Thus, the diagrams make it possible to estimate the possible dynamic load/deformation amplification.

The failure probability of superstructures on a rubble mound breakwater has been evaluated using a level II FORM reliability analysis. This analysis involves not only the simple failure mode sliding and lifting but also the various soil mechanic slip surface and zone failures. The reliability analysis will be extended to cover the other failure modes studied in the project.

Model tests were also performed in order to study the failure mode interaction between the main armour and the wave wall in a breakwater with front slope 1:1.5. Horizontal wave pressure and uplift forces on the superstructure have been measured by pressure cells. The test results reveal that an increase in the armour damage will lead to an increase in the wave force acting on the superstructure. A relation between wave loadings and armour damage level has been developed.

Interaction between wave wall - rear slope stability

A re-analysis of existing test results of low-crested structures resulted in design diagrams for the front slope, crest, rear slope and the whole structure. Beside this, model tests were carried out with 6 categories of rocks in order to study the influence of rock shape and gradation. A stability curve for each category of rock material has been established.

4 Design guidelines

On the basis of failure modes formulated in the various subtasks and in the previous research the partial safety factors were developed with the design lifetime of 50 years (EUROCODES).

The following failure modes have been considered

Stability of conventional armour

- Hudson formula
- Van der Meer formulae for rock (plunging waves and surging waves), cubes and tetrapods
- Burcharth formulae for Dolos (with and without a superstructure) and parallelepiped block armour
- Berenguer formulae for hollowed cubes and hollowed Antifer blocks in trunk and round-head

Toe-berm stability

- Burcharth (modified Gerding) formula

Run-up

- Hunt-van der Meer formula for rock armour slope
- Burcharth formula for Dolosse
- Berenguer formula for hollowed cubes and hollowed Antifer blocks

Breakage of armour units

- Burcharth formulae for Dolosse in trunk and in round-head and Tetrapods

Scour in front of roundheads

- Fredsøe formulae for scour depth by steady stream and breaking waves

Foundation slip failure and sliding of superstructures

For all the above failure modes, the limit state functions are formulated, uncertainty quantities are modelled by stochastic variables and the design equations are given. The design equations include three partial safety factors, namely

- a strength safety factor γ_R
- a load partial safety factor γ_P to be multiplied to the permanent load
- a load partial safety factor γ_W to be multiplied to the variable load (wave load).

These partial safety factors are obtained by the calibration using the First Order Reliability Methods (FORM), where the reliability is measured by reliability index. The calibration covers the failure probability from 0.01 to 0.4.

In the reliability design against the above mentioned failure modes, one can simply pick up the partial safety factors according to the specified failure probability, insert them into the design equation and obtain the results.

5. ACKNOWLEDGEMENT

In preparing this paper use has been made of the contributions from all the partners in the project. The project is funded by the European Communities under the contract MAS-CT92-0042.

6. REFERENCES

- *Report on the start-up workshop, RMBFM-Project (Contract MAS2-CT92-0042)*. June 1993, Hørsholm, Copenhagen, Denmark, Edited by Aalborg University.
- *Scour at coastal structures workshop report no. 1, RMBFM-Project (Contract MAS2-CT92-0042) and MCS-Project*. June 1993, Hørsholm, Copenhagen, Denmark, Edited by Danish Hydraulic Institute.
- *Proceeding of the 2nd workshop. RMBFM-Project (Contract MAS2-CT92-0042)*. January 1994, Bressanone, Italy, Edited by University of Bologna and Aalborg University.
- *Proceeding of the 3rd workshop, RMBFM-Project (Contract MAS2-CT92-0042)*. November 1994, De Voorst, the Netherlands, Edited by Aalborg University.
- *Proceeding of the 4th workshop, RMBFM-Project (Contract MAS2-CT92-0042)*. Aalborg, Denmark, on June 8 - 9, 1995, RMBFM-Project.
- *Final proceedings of RMBFM-project, (Contract MAS2-CT92-0042)*.

7. NOTATION

A	uncertainty of formula
B	relative number of breakage of armour units bottom width of breakwater rounhead
C	fitted parameter
D	relative number of displacement of armour units
D_n	equivalent cubic length
h	water depth
H_s	significant wave height
KC	$KC = \frac{U_m T}{B}$
M	mass of armour units
N_0	number of armour units displaced within a strip of width D_n
N_s	stability number $N_s = \frac{H_s}{\Delta D_n}$
N_z	number of waves
r	Dolos waist ratio
R_u	wave run-up
S	tensile strength of concrete scour depth
T	wave period
U_{max}	maximum horizontal velocity of water particle at sea bottom
Δ	$\Delta = \frac{\rho_{armour}}{\rho_{water}} - 1$
φ	packing density
ξ_p	surf similarity parameter $\xi_p = (\cot\alpha)^{-1} s_p^{-0.5}$ $s_p = \frac{H_s}{gT_p^2}$