

Archaeological evidence for eustatic and tectonic components of relative sea level change in the South Aegean

by

FLEMMING, N. C., CZARTORYSKA, N. M. G., & HUNTER, P. M.

SUMMARY

Seventy archaeological sites were visited on the coasts of the Peloponnese and south-west Turkey in 1967-69. Relative sea level changes were detected at each site by interpreting the function of remains and foundations and attempting to relate these to the original sea level at the site when it was occupied. The age of sites varied from 2000 B.C. to medieval and modern structures of the past 100 years. The relative displacement of sites varied from relative uplift of 3.0 m to submergence of 5.0 m.

There was no simple correlation between age and displacement of site, and therefore the observations could not be explained by steady continuous movement of either the land or the sea. The average displacement of sites increased towards relative depression with increasing age, but the scatter between sites of the same age always exceeded the average displacement for that age, indicating a high incidence of earth movements between sites. This is to be expected in view of the intense faulting and seismicity of the region.

The data for the Peloponnese were treated with surface fitting programmes. The average rate of displacement for each site was correlated with its geographical co-ordinates on an arbitrary local grid. Third-degree surfaces for the east and west coasts independently produced the best fit, and a smoothing equation was computed for the junction between the areas. The contours of rate of relative displacement indicate that the margins of the Peloponnese are being depressed while the centre is being uplifted. A ridge of relative uplift extends through the Elos peninsula, Kythera and Antikythera towards Crete.

The data from Turkey were both recorded and analysed with a more advanced technique. Estimates of the probability of various displacements other than the most probable were made, and the resulting figures were treated for separation of the factors due to earth movement and eustatic change of sea level. It was proposed that the eustatic change of sea level through time could be represented by a third-degree equation, while the geographical distribution of rate of earth movements could be represented by a fourth-degree equation in local geographical co-ordinates. It was proposed that the observed relative displacement at a site should be the sum of these two factors. The expressions were expanded into their algebraic terms, and a stepwise multiple regression fitted to the combined expression. The best fit equation was separated into those terms in time only, those including geographical co-ordinates, and the two equations plotted separately. The eustatic sea level/time curve indicated that sea level was within a few centimetres of present level at 2000 B.C., dropped slowly to about -30 cm in about A.D. 500, and then rose to present level. This is, of course, a smoothed curve and there may have been oscillations about this mean with periods of a few hundred years. The contours of earth movements showed complex warping and faulting of the Turkish coast, with a general depression to seawards and landwards about the mean coastal axis, and regions of uplift stretching westwards over the Çeşme peninsula and west of south from the Cnidus peninsula towards Rhodes.

In the present paper the archaeological observations are presented with sketch maps, and the mathematical and geological interpretation is summarized with reference to other publications.

INTRODUCTION

COASTAL ARCHAEOLOGICAL sites provide an excellent sea level indicator in the time span 1–5,000 years, with an accuracy varying from ± 1.0 m to as little as ± 0.1 m. To obtain a reliable sample on which to base deductions about earth movements and eustatic sea level changes, it is necessary to locate a large number of sites in the area; this sometimes leads to the discovery of new sites. Even where sites are previously known, often only the briefest descriptions have been published of ruins on the beach or underwater, and the simple survey needed to establish the magnitude of relative sea level change may have original archaeological value in its own right.

In 1967, 1968 and 1969 surveys were conducted on the coasts of the Peloponnese and south-west Turkey, and a total of 69 sites was studied. In spite of the excellent general archaeological publications on the region (Waterhouse & Hope Simpson, 1961; Hope Simpson, 1965; Bean, 1966; Bean & Cook, 1952; 1957; Newton, 1863; Stark, 1956), and the detailed charts and more specific archaeological reports, it was quite difficult to locate some sites, while others were almost inaccessible. In many cases large areas of ruins were noted both on shore and in the water, but it is beyond the scope of the present study to attempt detailed archaeological surveys. It therefore seems desirable to reproduce the sketch-maps of the sites visited, both to substantiate the exact nature of the evidence used to derive sea levels, and as an aid to archaeologists who may be able to deduce from them those sites which merit more professional study or excavation.

The geological and geophysical results of the survey have been published in interim form (Flemming, 1968*a* & *b*), and a fuller analysis is given by Flemming (1972). In the present paper the archaeological observations will be presented, followed by a summary of the mathematical techniques used to separate local earth movements from eustatic sea level changes. Methods for deducing sea levels from archaeological remains near the shore are given by Flemming (1969).

METHODS

Sites visited are shown in Figures 1 and 2. In most cases surveying methods were extremely primitive. Sites were located either from published literature, or by following up local stories, or by searching the coast with polarizing glasses to cut out the dazzle from the water, or on a topographic basis, that is, by deducing likely sites for harbours from the topography of the coast and the offshore zone. The following sites were surveyed in some detail: Elaphonisos (Harding, Cadogan & Howell, 1969); Gythion, with a sextant and tapes; Asopus, with tapes and rules. The remainder were sketched with the aid of pacing, rules, estimation of distances by eye, and measurements from photographs. In some cases the large-scale Admiralty charts provide a good basis for the outline of a site map. Depths were measured accurately by rule, where less than 3 m, and were measured by a diver's depth gauge or taken from the charts, where greater.

The date attributed to a structure from which a sea level is derived is taken from previously published observations, usually based on historical sources and pottery, modified where necessary by approximate judgements based on styles of masonry. Thus, an obviously medieval structure may be the best indicator of sea level changes at a site where the principal archaeological interest is focussed on a much earlier period. Except at Elaphonisos, where the underwater site was fully surveyed in 1968 (Harding,



Figure 1. Archaeological sites in the Peloponnesse studied in 1967 and 1968.

Cadogan & Howell, 1969), no special attempt has been made to obtain dates from pottery or artifacts in connection with determinations of sea levels. Thus, errors in dating are probably of the order of 200–500 years, while errors in estimation of vertical displacement are of the order of 20 cm. In both cases the error is of the order of 10–20% of the value estimated. Probability estimates of the likelihood of different vertical displacements of sites were made for sites on the Turkish coast, as explained in a later section.

For each site visited the following data are given: ancient name or names, modern name or names, latitude and longitude measured on the largest-scale Admiralty chart, Admiralty chart number at the largest scale, classical references, and modern

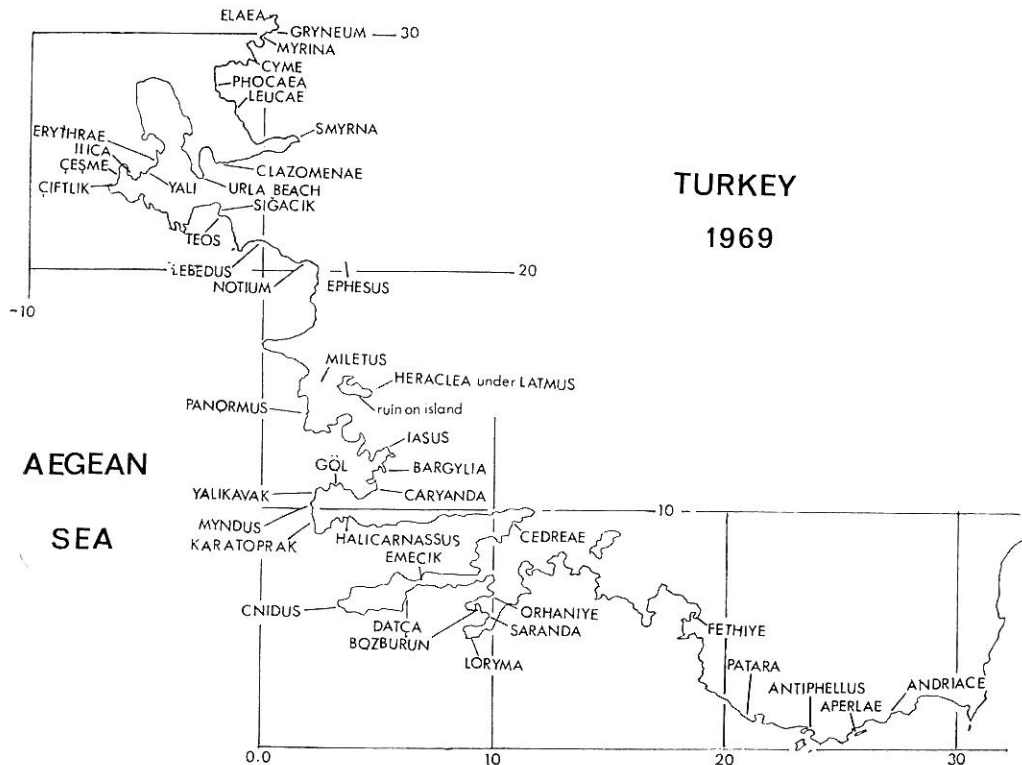

Figure 2. Archaeological sites in South-West Turkey studied in 1969.

archaeological references. This is followed by a brief summary of archaeological observations, with reference to sketch maps, and conclusions about relative sea level change.

SITES IN THE PELOPONNESE

- ✓ LECHAEUM (near Corinth). $37^{\circ} 56' N.$, $22^{\circ} 52' E.$ Chart 1600. Pausanias 2.1.5. Fowler & Stillwell (1932). Figure 3.

Areas of blocks on either side of the harbour entrance suggest training moles to prevent silting or provide additional shelter. Slight submergence of tower foundations along the coast to the west, combined with the relation of the water level to the walls of the entrance channel, suggest submergence of not more than 70 cm.

- ✓ CENCHREAE. Kenchreai. $37^{\circ} 52' N.$, $23^{\circ} 00' E.$ Chart 1657. Pausanias 2.1.5. Scranton & Ramage (1964), Hawthorne (1965).

The southern mole provides the base for the foundations of a number of buildings and interconnecting tanks, all of which are submerged. In particular, a cross wall supports a flight of steps which begins beneath the water and descends 1 metre to the rubble. It is probable that there has been a relative change of level of up to 2 m.

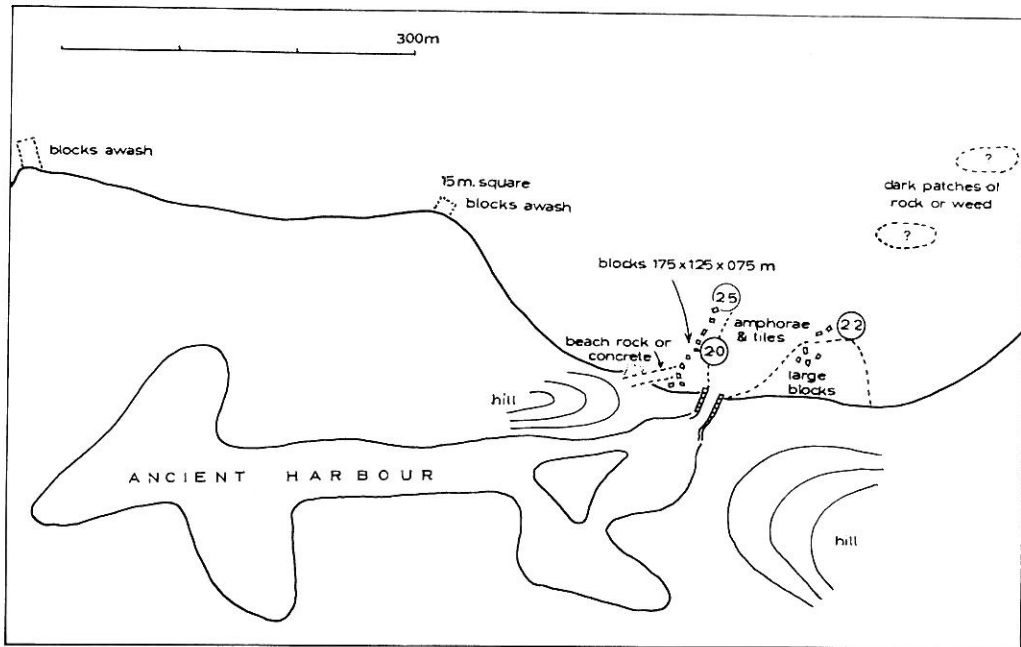

Figure 3. Lechaemum.

EPIDAUROS. Palia Epidavros. $37^{\circ} 38' N.$, $23^{\circ} 09' E.$ Chart 1657.
Pausanias 2.26-9. Figures 4 and 5.

There are foundations underwater on the north and south sides of the peninsula at the points marked A and B. At site A two sets of parallel ashlar walls project at right angles into the sea terminating at a depth of 2 m. At site B a considerable area of house walls is submerged, including a floor *in situ*, and the ashlar foundations of a larger structure. A gutter channel lined with tiles slopes to a depth of 2.5 m near the houses, and there are larger blocks of masonry 75 cm thick, with foundations in 3.0-3.5 m. The gutter must have been above water level when in use, but the thicker walls may have been built in the water as parts of dockside structures rather than houses. The most probable submergence is therefore 2.7 m.

METHANA. Vathi, near Methana. $37^{\circ} 35' N.$, $23^{\circ} 20' E.$ Chart 1518.
Pausanias 2.34.1.

On the west side of the Methana peninsula, south of the fishing harbour of Vathi, is a shallow bay backed by an acropolis heavily built over with large ashlar structures and some rougher stone and mortarwork. At the southern end of the bay a river debouches near a cliff, and there are walls in a depth of 1.0 m. All along the shore of the bay there are cut stones and rubble in the water to a depth of 2.0 m, but no foundations *in situ*. The few modern houses on the shore are partly undercut and collapsing into the water. There is indication of probable submergence by 1.0 m since the classical period.

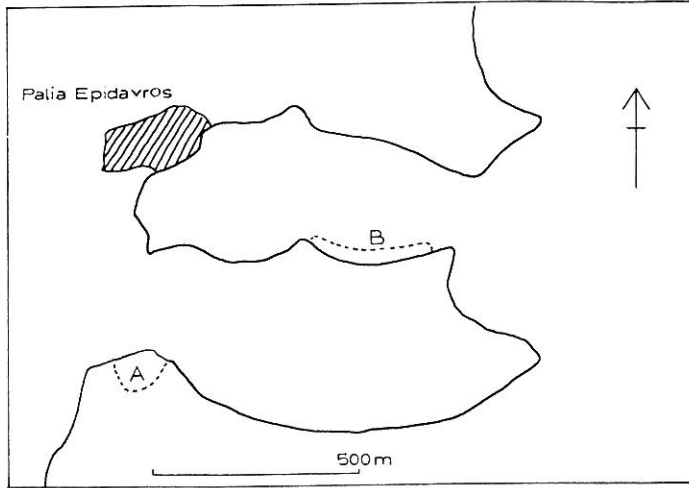

A

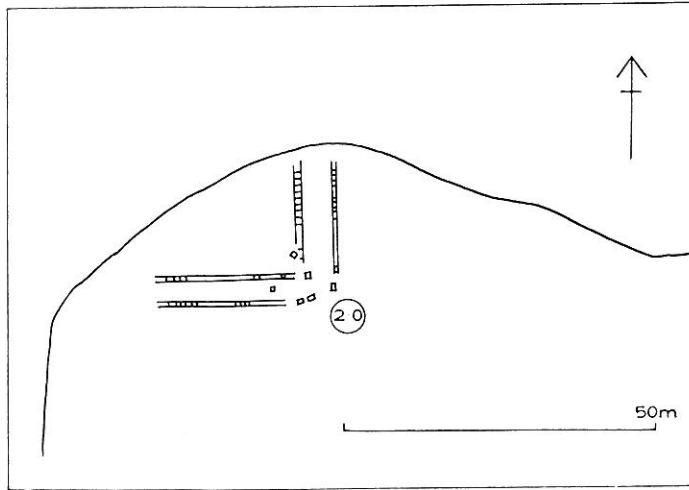

B

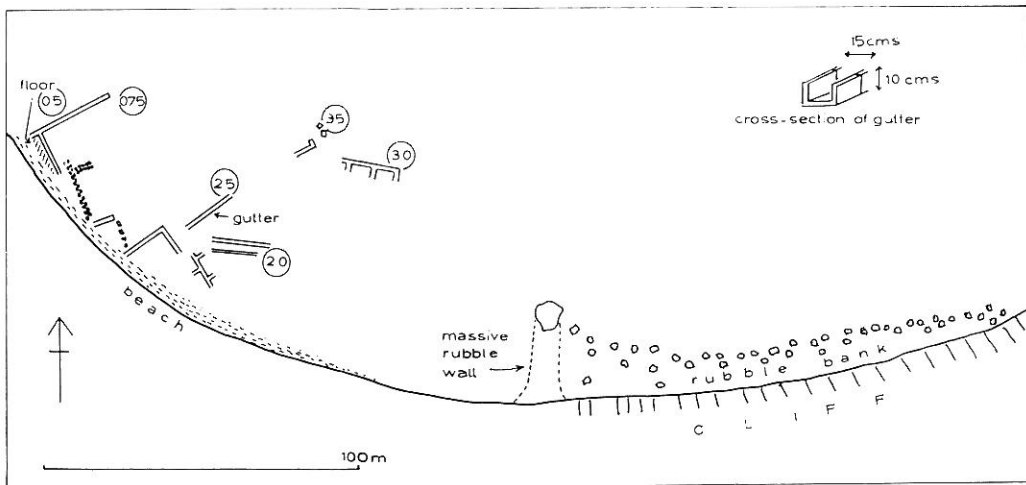

Figures 4, 5. Epidaurus.

HALIEIS. Porto Cheli. 37° 19' N., 23° 09' E. Chart 1518.

Pausanias 2.36.1. Ervin (1967, 299 & pl. 88), Jameson (1969).

The ruins in the water on the south shore of the bay date from the fifth century B.C. to Byzantine times. There are further fragments of buildings and roads on the north side of the bay. There is extensive indication of submergence by about 5 m.

ASINE. Tolon. 37° 32' N., 22° 53' E. Chart 1518.

Pausanias. 2.36.4-5. Frödin and Persson (1938).

In the bay to the south of the headland on which the Mycenaean city is situated are alignments of stones cemented with coralline algae which are probably the remains of walls. The stones are unshaped, and the area enclosed by the wall closest to the shore is marked by Frödin and Persson as a harbour, though this seems unlikely, on account of its small size and shallowness. The supposed walls are on a rocky platform under 2 m of water, beyond which the loose rubble slope drops rapidly to 5 m. Immediately south of the platform is an area of pottery and small stones, and a submerged strip of beach rock. It is not possible to say with any certainty that the beach rock and the walls are of the same date, but there is indicative evidence for submergence by 2.0 m since the occupation of the Mycenaean site.

ZARAX. Limen Ierakas. 36° 47' N., 23° 05' E. Chart 712.

Pausanias 3.24.1. Figure 6.

Landward of the modern village the bay is very shallow, but seaward there is a deep harbour. Probably in ancient times the bay was less silted, and ships could off-load

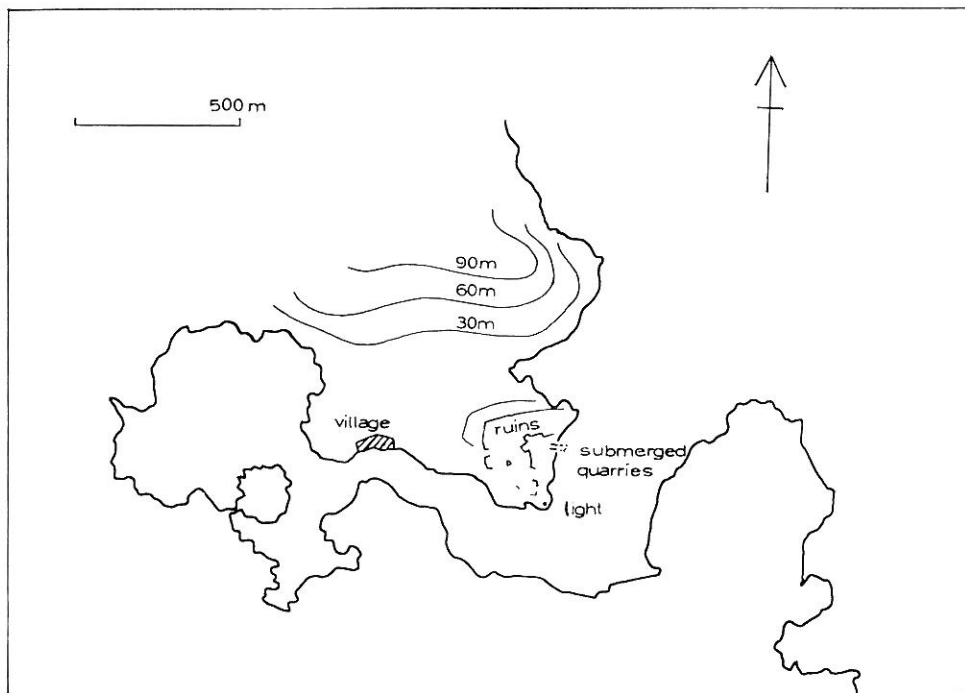

Figure 6. Zarax.

at the back of the bay. Towards the entrance the cliffs are so steep and high on both sides that landing would be almost impossible, especially on the south shore. Beneath the city walls the cliffs descend steep but not sheer, and there is no space for any construction of harbour works. There are, however, some signs of quarrying, and cut recesses suggesting a small landing-place, with cuttings and steps descending 3 m underwater.

MINOA. Monemvasia. $36^{\circ} 41' N.$, $23^{\circ} 03' E.$ Chart 712.

Pausanias 3.23.11. Figure 7.

One kilometre north of Monemvasia and visible from the road is an area of flat rock about 50 m square jutting into the sea and mostly submerged. There are some projections above the water, but most of the platform is awash, and the surface is quarried, with the marks of individual blocks having been removed. There are some depressions which could possibly be for foundations. The depth of water over the cuttings is 75 cm, indicating submergence of at least 1.0 m. Along the southern shore of the island of Monemvasia are numerous ruined houses and foundations, but none of these descends below sea level. An illustration of the city in the eighteenth century shows houses in this area.

Three kilometres north of Monemvasia are the ruins of Epidaurus Limera, on a rocky hill. On the beach below the city, between the mouth of the stream and the foot

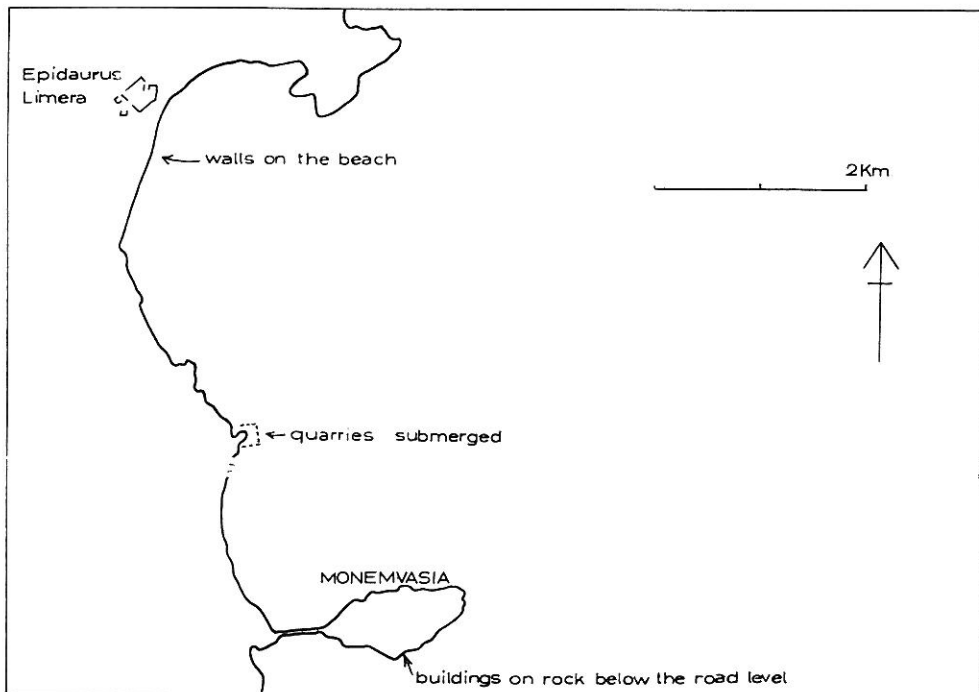

Figure 7. Monemvasia.

of the acropolis, there is a long wall foundation about 1 m above sea level. There were no walls found in the water, and no evidence was found from which a change of sea level could be deduced.

BOEAE. Neapolis. $36^{\circ} 31' N.$, $23^{\circ} 02' E.$ Chart 712.

Pausanias 3.22.11. Waterhouse & Hope Simpson (1961, 142-4).

About 1 km north of Neapolis, where the bathing beach terminates against the rocks, there are cuttings and quarries awash to a depth of 30 cm. At the mouth of the river by the site of ancient Boeae there is an extensive beach rock sloping to a depth of 5 m, indicating a continuous rise of sea level.

ONUGNATHUS. Elaphonisos, Pavlo Petri. $36^{\circ} 28' N.$, $22^{\circ} 59' E.$ Chart 712.

Pausanias 3.22.10. Strabo 8.5.1. Negris (1904), Waterhouse & Hope Simpson (1961, 145-8), Flemming (1968*b*), Harding, Cadogan & Howell (1969). Figure 8.

Obsidian chips and Bronze Age sherds have been found on the beach on either side of the Elaphonisos Strait for many years. In 1967 a search between the mainland shore and the islet of Pavlo Petri revealed an area of Helladic ruins 200 m by 300 m. In 1968 a full survey was made on which the present map is based. In several regions of the site foundations of houses extend out to but not beyond the 3.0 m isobath, suggesting a change of level of the order of 3.0 to 3.5 m. Elaphonisos Island was still connected to the mainland at the time of Pausanias (second century A.D.), and the Strait was still fordable in the seventeenth century.

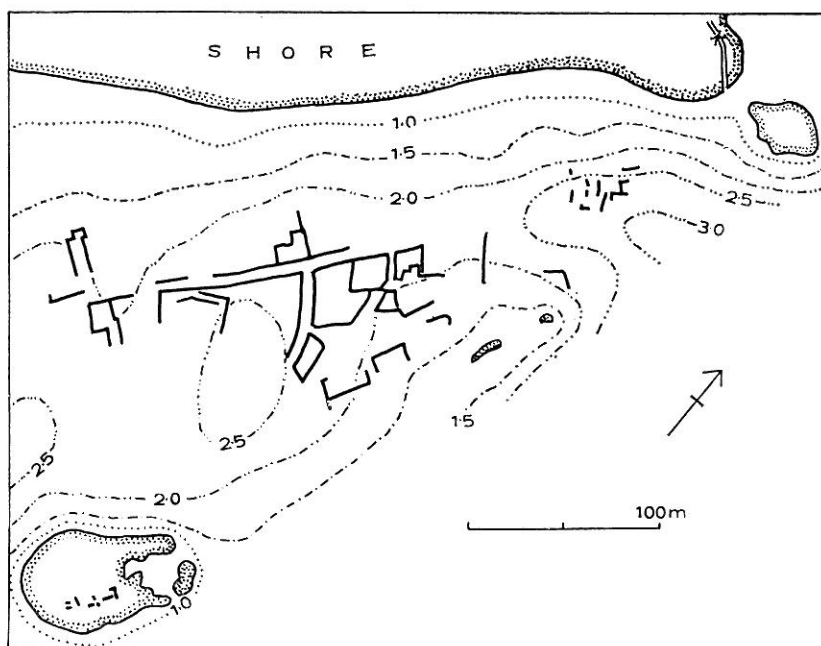

Figure 8. Pavlo Petri.

ARKHANGELOS (modern name). 36° 37' N., 22° 53' E. Chart 3372, 712.

On the north side of the rocky promontory about half way along its length are some small quarries submerged by 20 cm. In the village a number of capitals and columns have been found, but there are no harbour works.

ASOPUS. Plitra. 36° 41' N., 22° 50' E. Chart 3372, 712.

Pausanias 3.22.9. Figures 9 and 10.

The land site occupies a broad flat peninsula and there is no obvious harbour. The bay to the east is broad and open to the waves, and would only provide shelter from a northerly or easterly wind. Below the water level the promontory swings round to the south-east (see Fig. 9), so that if the sea had been lower the entrance to the bay would have been of less than half the present width. This submerged area of the promontory is covered in ruins of various ages.

At the southern limit of the submerged area is a network of long walls in lengths of 10–20 m, standing up to 1 m high, in a water depth of 3 m. They are of a primitive type, composed of unshaped stones and without mortar. The stones are odd in that they are well rounded from beach or stream action, and are quite white and not covered by marine growth. By analogy with Elaphonisos it is probable that these walls are of Helladic origin, indicating submergence of at least 3.0 m in 3,000 years.

The eastern limit of the submerged area is bordered by a rubble bank composed of stones similar to those in the walls already mentioned. Broken pottery is scattered among stones. It is not clear whether this bank was originally a mole or jetty, or whether it is simply the result of earlier walls having been destroyed by waves as the sea level rose and the stones being swept over the rock ledge into deeper water. A massive concrete pier projecting from the rubble mound and totally submerged suggests that it was a mole or jetty purposefully constructed. Nearer the shore there are areas of well preserved ashlar in shallow water, interspersed with rough walls of mortar, tiles and rubble. There are also tanks and an olive-press. Stretching seaward from the south-east corner of the headland and sheltered by the submerged area, there are large structures of mortar, tile, and stone, with one apsidal building, indicating submergence of 2.0 m since the late Roman or Byzantine period (Fig. 10).

ARAGORA (modern name). Kythera. 36° 13' N., 23° 05' E. Chart 1685, 712.

At the Minoan site of Aragora there does not appear to have been any change in sea level, though there is a possibility that there has been a slight relative drop of sea level.

POTAMOS (modern name). Antikythera. 35° 53' N., 23° 17' E. Chart 1685, 712.

Figure 11.

In spite of the apparent shelter provided by Ormos Potamos, the prevalence of northerly winds makes it insecure. It is probable that the ancient harbour was in the creek on the east side of the bay, immediately beneath the slope of the acropolis. The bar of large cobbles which rises 4 m above the level of the present stream mouth, the wave-cut notch at +3 m behind the bar, and the numerous solution notches in the cliff up to a height of 3 m on both sides of the creek, all indicate a relative drop in sea level. The most probable explanation is that the island, which is of volcanic nature, has been uplifted discontinuously, but repeatedly, with a notch formed at each standstill.

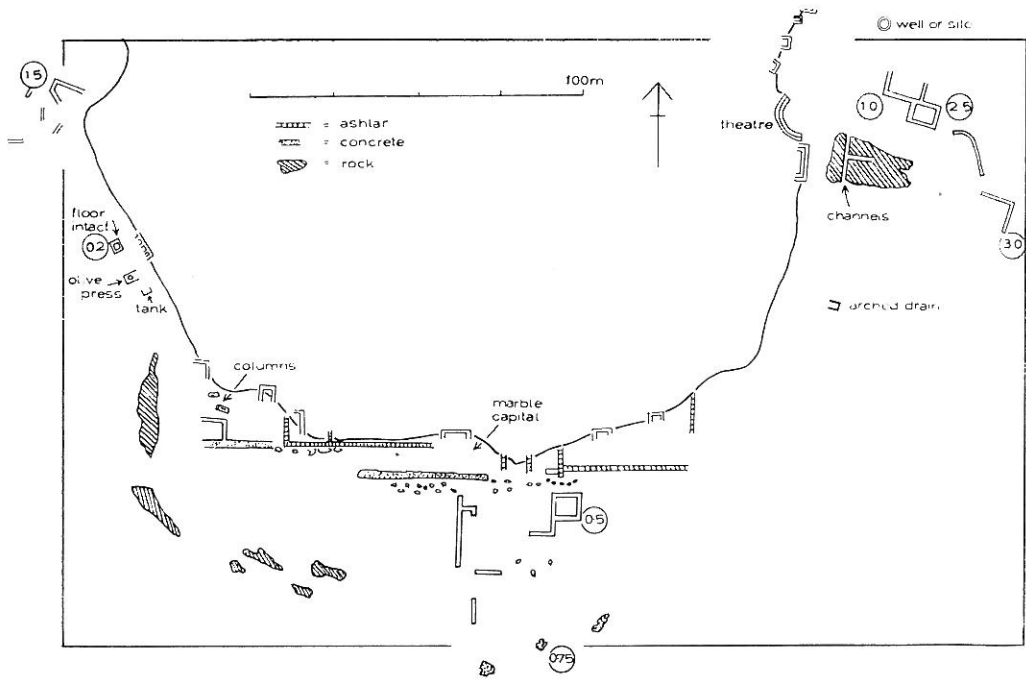
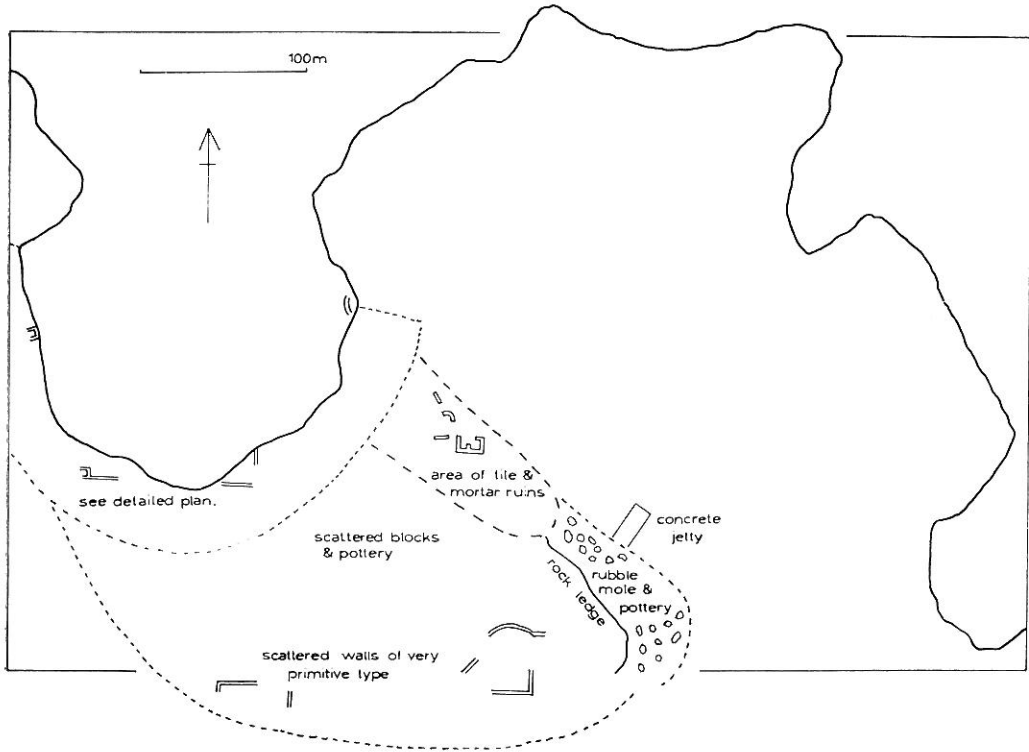

Figures 9, 10. Plitra.

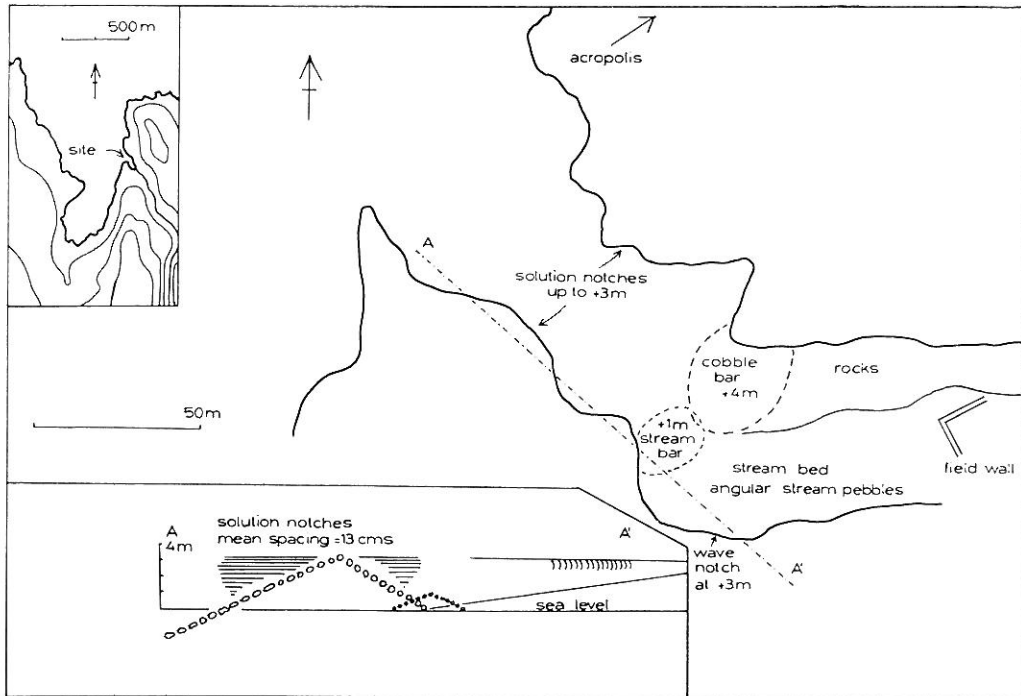

Figure 11. Ormos Potamos.

The spacing between the notches is about 13 cm on average. During the Flandrian transgression the rise of sea level would have been faster than the uplift of the island, but when the eustatic sea level approached its present level in about 3000 B.C. the continued uplift of the island would produce the notches. Thus there is evidence for uplift of 3.0 m in 5,000 years.

ACRIAE. Elea. $36^{\circ} 44' N.$, $22^{\circ} 48' E.$ Chart 3372.
Pausanias 3.22.4.

South of the bay containing the modern harbour of Elea is an area of shallow water and rocky outcrops of breccia, with fragments of pottery wedged in cracks. There is one rectangle of unsquared blocks, similar to those at Plitra, approximately 10 m square. North of the modern harbour, round a small headland, are a number of submerged patches of similar stones, quite distinct from the local rock, at depths of 2 to 4 m. While the purpose and nature of these features is unknown, they may have been solid towers or hollow dwellings which have collapsed. By analogy with Plitra there is evidence for submergence of 2 m in 3 millennia, but this is very approximate.

TRINASUS. Trinisi. $36^{\circ} 47' N.$, $22^{\circ} 36' E.$ Chart 3372.
Pausanias 3.22.3. Figures 12 and 13.

At the southern end of the long sandy bay south of the rocks known as Trinisi, is a medieval church with a domed roof almost completely buried in sand dunes and

concealed by bushes and reeds. A wall of mortar, stones, and tiles emerges from the sand 3 m above water level, and continues about 0.5 m above the sand straight into the water for a distance of 10 m at a depth of 1.0 m. About 30 m to the north a similar wall extends into the sea, and the two are partly joined by a cross wall. A length of marble column-drum was found at water level. There is clear indication of submergence by 1.0 m.

The small bay opposite Trinisi rocks (Fig. 13) is almost filled with foundations in the water. The walls are of rough uncut stones and mortar, with some tiles, and are largely embedded in beach rock which is beginning to cover the structure. The remains appear to be those of a house or group of houses surrounding a yard. The deepest wall is in 1.0 m of water, indicating submergence of this amount.

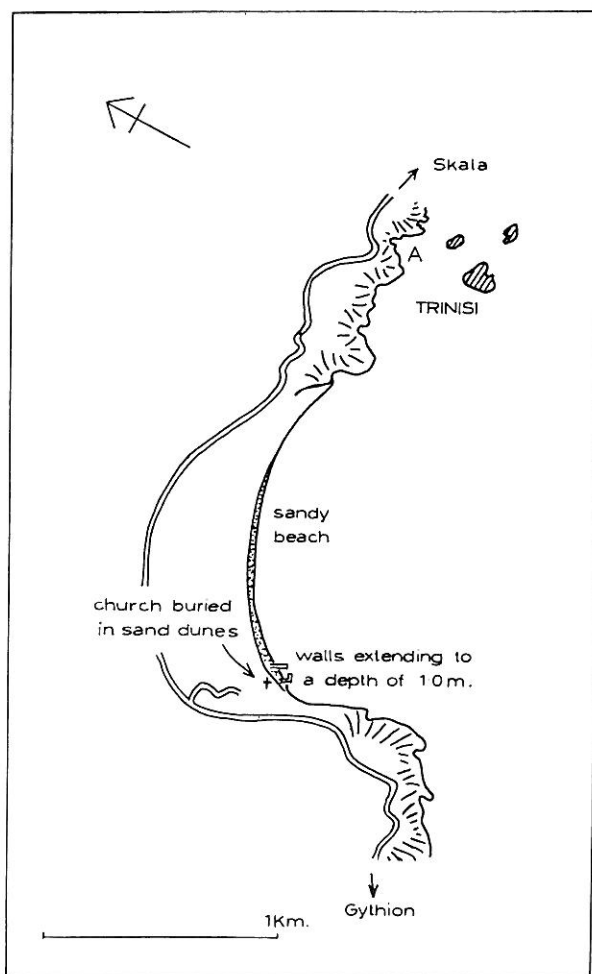

Figure 12. Trinisi.

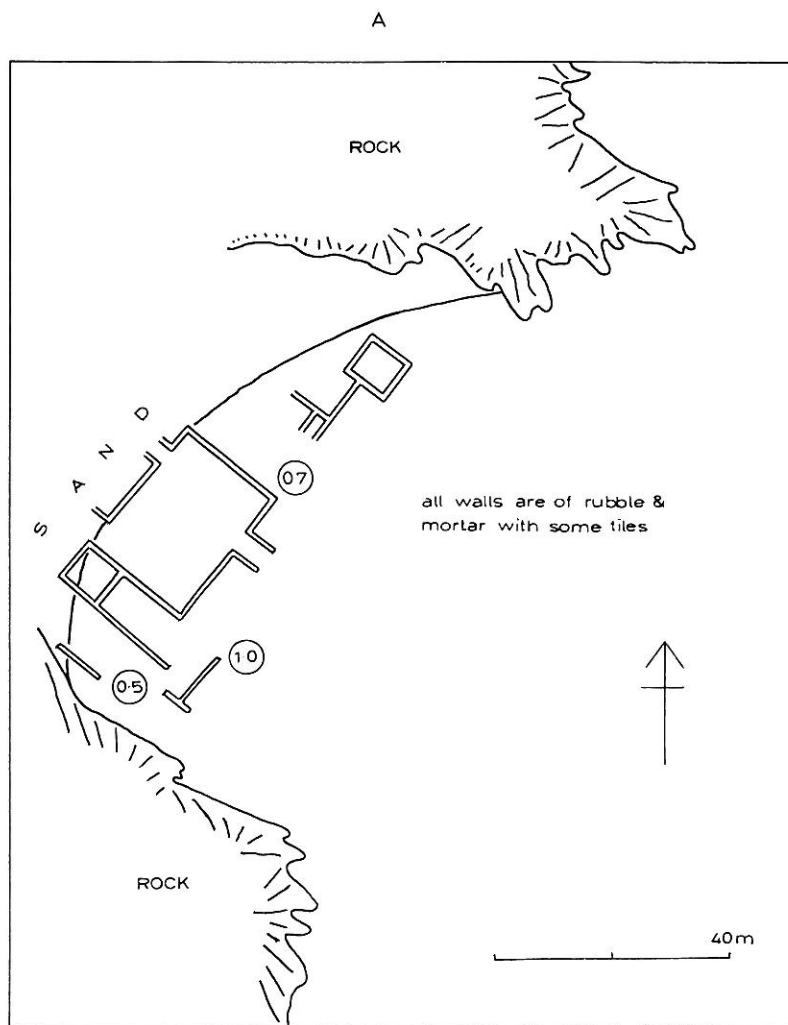

Figure 13. Trinisi.

GYTHEUM. Gythion. $36^{\circ} 45' N.$, $22^{\circ} 34' E.$ Chart 712.
 Pausanias 3.21.6–22.2. Giannakopoulos (1966). Figure 14.

The ruins surveyed in the water are adjacent to recovered land at the northern side of the modern harbour. The fill used to reclaim the land from the sea has undoubtedly concealed a further extensive area of ruins. In the zone mapped were found the remains of a mole, a tiled tank, long walls of ashlar, house foundations, and chunks of mortar and tile construction. The deepest land structures are in 2.5 m, indicating submergence by this amount since late Roman times.

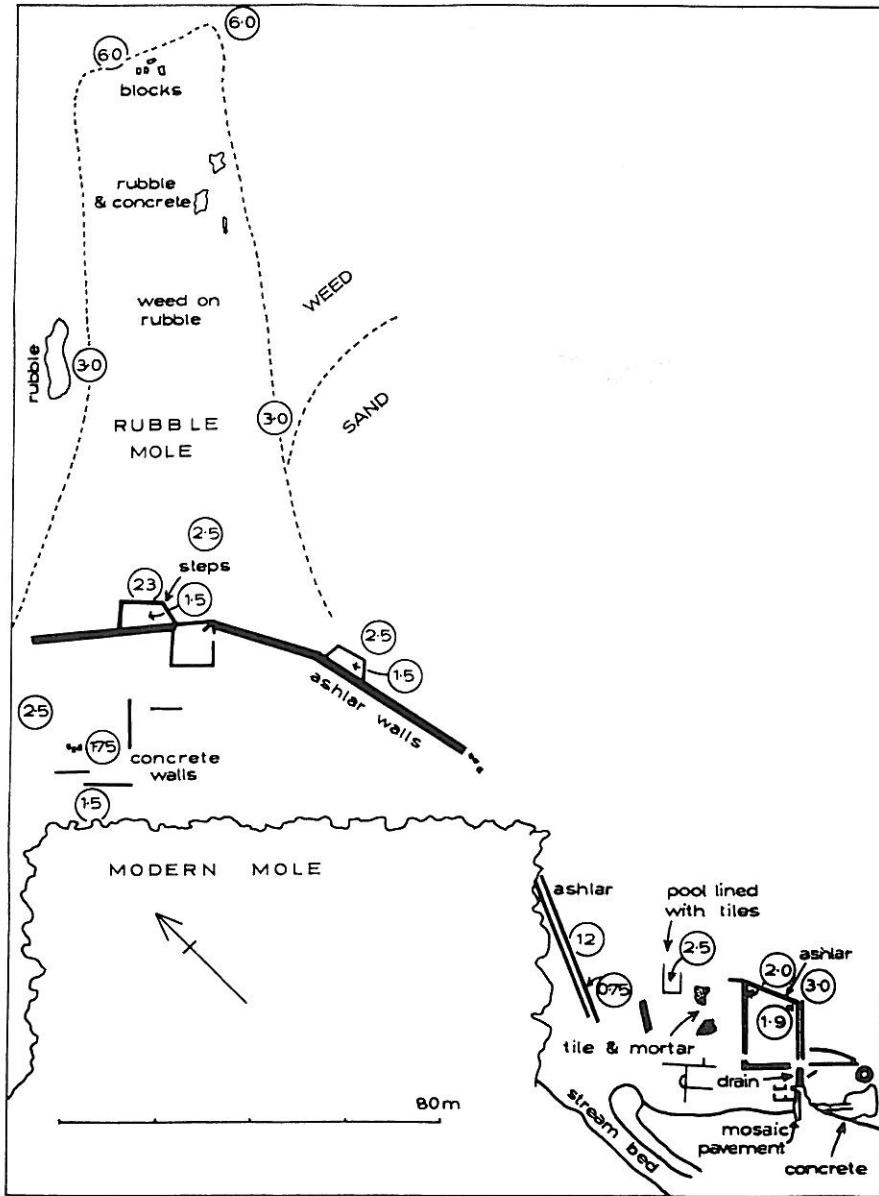

Figure 14. Gythion.

SKOUTARI (modern name). 36° 40' N., 22° 30' E. Chart 712.

There is an abandoned church on the beach. One hundred metres directly offshore from the church is a strip of rubble or broken wall in 3.5–4 m of water parallel to the shore. There are several squared blocks about 0.5 m square and one block of 1 × 0.5 × 0.3 m; also some blocks of mortar and tile work. It is not certain whether all this material

is *in situ*; it could be the remains of a building which has collapsed owing to erosion, or the remains of a mole made out of debris of earlier buildings. The presence of the mortar and tile work suggests collapsed structures *in situ*, indicating submergence of about 3.5 m.

TEUTHRONE. Kotronas. 36° 37' N., 22° 29' E. Chart 3372.
Pausanias 3.21.7,25.4. Figure 15.

On the mainland west of the spit are a number of buildings broken open by the sea, and some rock-cuttings awash. There is a bath with marble floor, and a round room. These buildings date from about the third century A.D. (Delivorias, personal communication). Where the spit joins the island there is a fortified wall and a medieval church. The wall continues into the water, and large fragments of stone and mortar and tile work continue south-eastward for 75 m at a distance of 5–10 m from the shore. The area of rubble extends slightly eastwards, and the deepest masonry is in 3.0 m of water, although the average depth by the wall is only 1.0 m. There is clear indication of submergence by 1.0 m.

TAENARUM. Limen Asomatos. 36° 24' N., 22° 29' E. Chart 712.
Pausanias 3.14.2,25.4–8. Figure 16.

Rock cuttings, a road cut in rock, and a number of buildings on shore date from the third century B.C. Foundations and cuttings near the shore are awash by 25 cm, and a well or cistern cut in the rock descends 0.8 m below sea level and has been broken into at the bottom by the waves. A line of ashlar blocks extends across the eastern inlet, joining the eastern side where the rock-cut road comes to the shore. This suggests the foundation of a quay. There has been some submergence, but there must have been at least 1 m of water beside the quay; therefore the total submergence is probably only 1 m. In both bays there is a great quantity of pottery on the sea floor, and this is possibly associated with votive offerings connected with the temple on the median headland.

TIGANI (modern name). 36° 32' N., 22° 22' E. Chart 1685.

This headland is near the town of Mezzapos, the ancient Messa (Pausanias 3.25.10). There are ancient and medieval structures on the headland. On the north side of the peninsula in a small bay below the fortress there is a broken tomb awash, indicating submergence by 0.5 m.

PEPHNUS. Selenitsa. 36° 49' N., 22° 18' E. Chart 1685.
Pausanias 3.26.2.

On the north side of the modern harbour there is an area of submerged walls and rock-cut basins. Adjoining the mole are four small basins with walls 50 cm high, with longer walls leading seawards in water 1.0 m deep. A quarry with its floor awash marks the end of the walls. The small basins may have been salt-pans, but the function of the remaining walls is uncertain. There has been slight submergence, but less than 1 m.

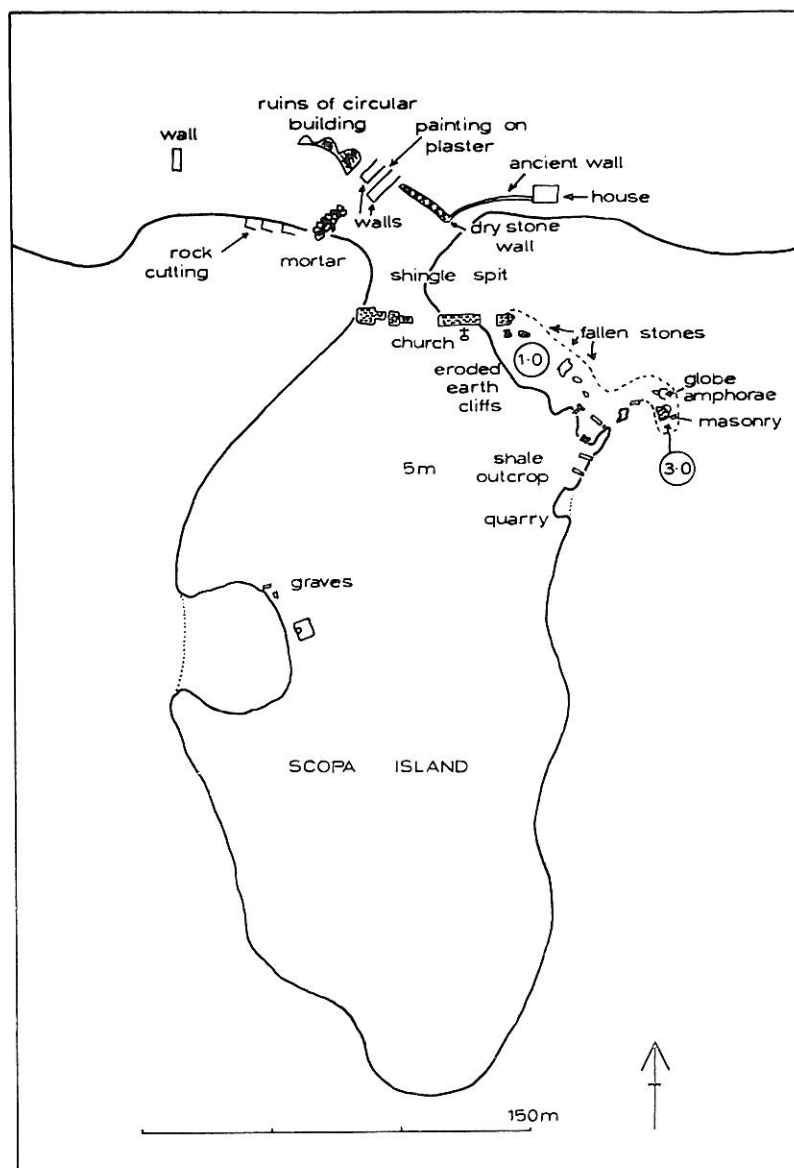

Figure 15. Kotronas.

LEUCTRA. Stoupa. 36° 50' N., 22° 16' E. Chart 1685.
Pausanias 3.26.4.

The bay north of the headland of Stoupa contains a central basin about 10 m deep, bordered on both sides by extensive areas 1–2 m deep from which project the apparent remains of two rubble moles. Rock cuttings and walls occur in the shallower areas to depths of 2 m, indicating submergence of the order of 2.5 m.

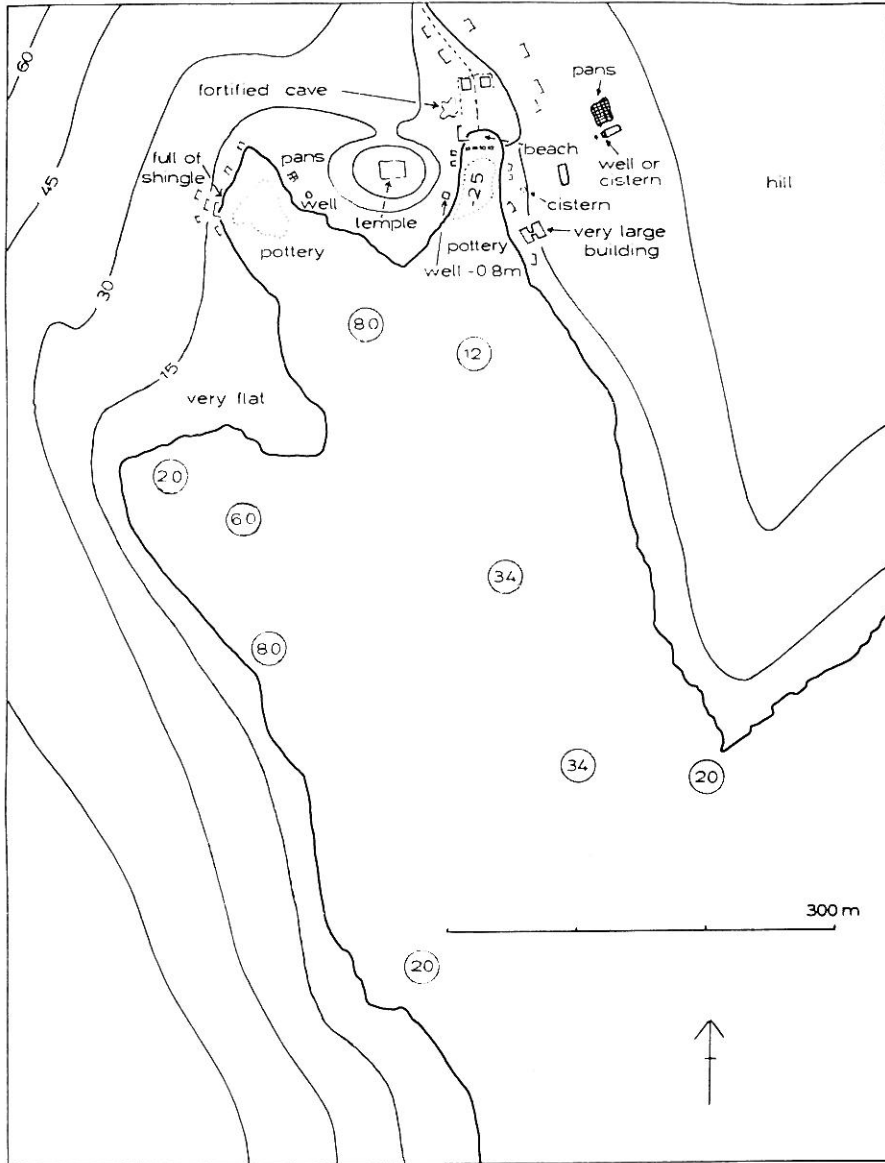

Figure 16. Taenarum.

CARDAMYLE. Kardamyli. $36^{\circ} 52' N.$, $22^{\circ} 15' E.$ Chart 1685.

Pausanias 3.26.7.

In the bay north-west of the modern mole there is a rectangular structure of roughly squared masonry, supporting one course of well cut blocks. It appears to be a base of a tower, but is not solid, and there is water within the walls. There is an iron ring on the outer face at the shoreward end, where the water is 1.0 m deep, and the structure has obviously been used as a landing-place, though it was probably not built as such. The

outer end is on a rock ledge, from which the depth descends to 3.0 m. There appears to have been a submergence of 1.0 m.

CORONE. Petalidi. $36^{\circ} 57' N.$, $21^{\circ} 56' E.$ Chart 719.

Pausanias 4.34.4. Hope Simpson (1966, 124).

Search of the bay, both inside and outside the modern breakwater, revealed no underwater structures, although there were many pottery fragments and parts of globe amphorae. The ribs of striated rock overlain by beds of beach rock gave the impression of artificiality, but in all cases turned out to be natural geological features. It was not possible to deduce a change of sea level from this site.

ASINE. Koroni. $36^{\circ} 48' N.$, $21^{\circ} 58' E.$ Chart 719.

Pausanias 4.34.9-12. Figure 17.

No remains of the classical period were found in the water. The first defensive wall surrounding the peninsula was built by the Venetians in the thirteenth century A.D., and was subsequently enlarged and modified by the Turks. On the north side of the peninsula there are some walls on the beach extending into 25 cm of water, and below the steep ramparts several thick walls *in situ* standing in 1.0 m of water, and a square building which once had a domed roof lined with plaster standing in 50 cm. The rough stone and mortarwork suggests a chapel outside the fortifications. There is clear indication of submergence by slightly more than 1.0 m.

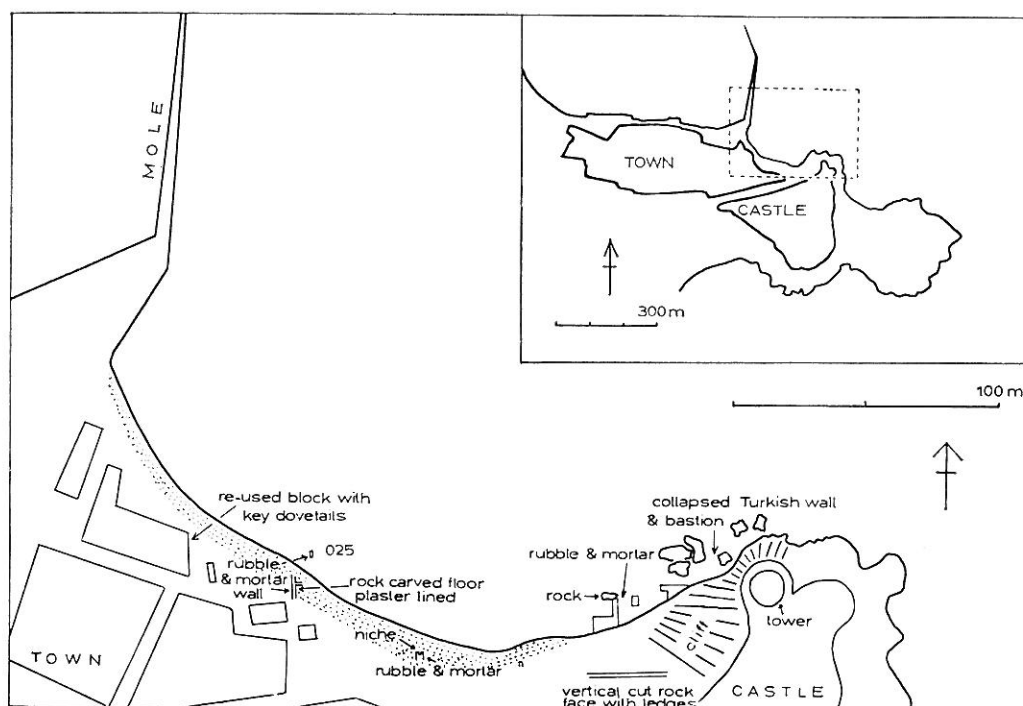

Figure 17. Asine.

METHONE. Methoni. 36° 49' N., 21° 42' E. Chart 719.
 Pausanias 4.35. Higgins (1966). Figure 18.

There were classical and Byzantine fortresses on this site, and the headland was fortified by the Venetians in A.D. 1206. Further defences were added by successive Turkish and Venetian occupiers. The octagonal tower at the south end was built by the Turks in the sixteenth century. The jetty to the east was built in 1870, and contains

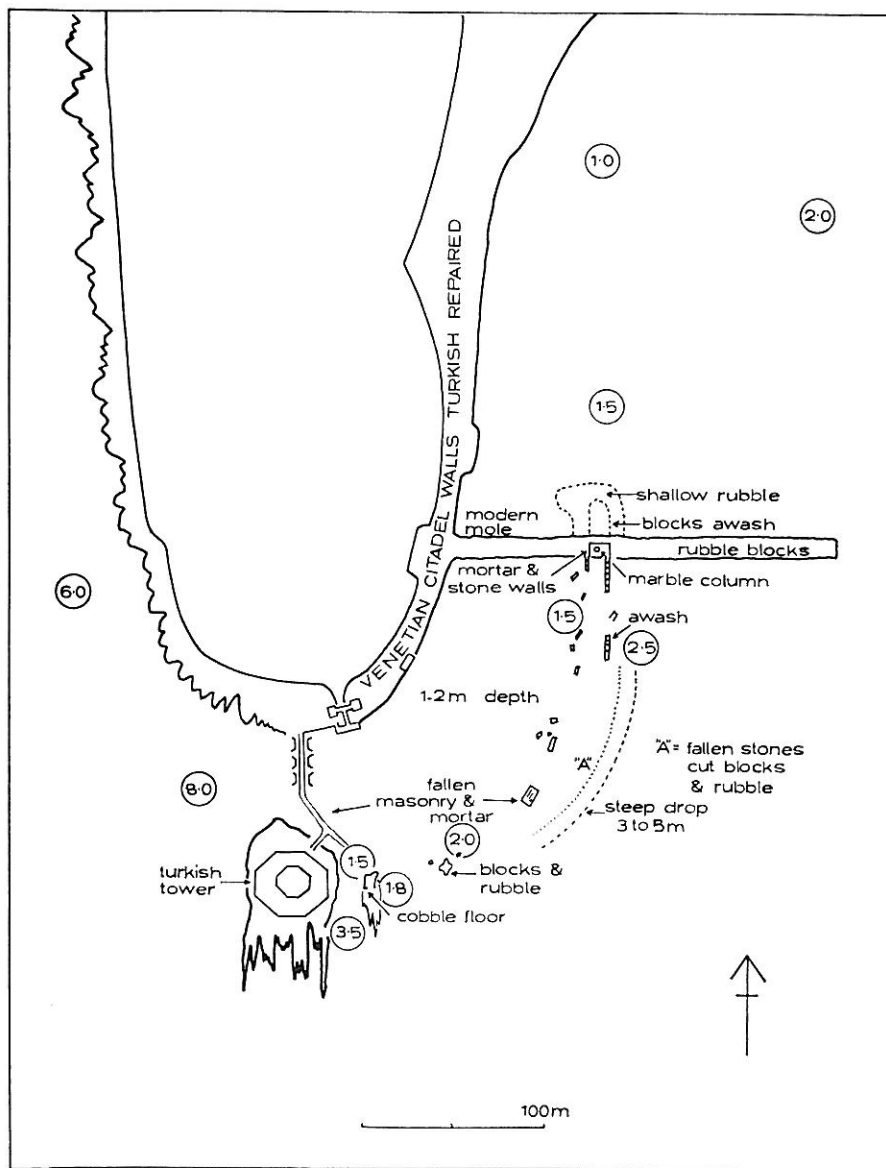

Figure 18. Methone.

an erect marble column which is embedded in masonry which predates the jetty. The area of rubble to the north of the column and the submerged walls to the south of it suggest that the column was a bollard in an earlier jetty. The submerged walls form a continuous arc from the column to the octagonal tower, always about 100 m from the shore, but the area enclosed was not searched in detail. The masonry remains in the arc suggest a double-faced wall with several towers built on the brink of a slope. It seems probable that the fortress extended out to this limit at one period, but that relative submergence forced the defences back to the present circumference. The remains of the wall were probably later modified to form a jetty or landing-place, and the marble column was embedded in the earlier structure to make a mooring-stone. This in its turn was incorporated in the modern jetty. The cobble floor on the rock next to the octagonal tower is just awash, and the walls leading south from the marble column are laid in 1.0 m of water, while other masonry lies broken in 2.0 m. The ruins in the water might be part of a Byzantine fortress, but are more probably of medieval origin, and indicate submergence by about 1.5 m.

PYLUS AD CORYPHASIUM. Navarino Bay. $36^{\circ} 57' N.$, $21^{\circ} 30' E.$ Chart 211. Pausanias 4.36.1–2. Thucydides IV. 26–41. Grundy (1896). Figure 19.

The ancient city of Pylus was on the hill to the north of the Strait of Sykia at the entrance to the Bay of Navarino, and a small harbour was located just inside the mouth of the Strait, later called Zouchio by the Venetians. A number of walls of various periods break off on the steep shore at the water's edge, but in the back of the bay

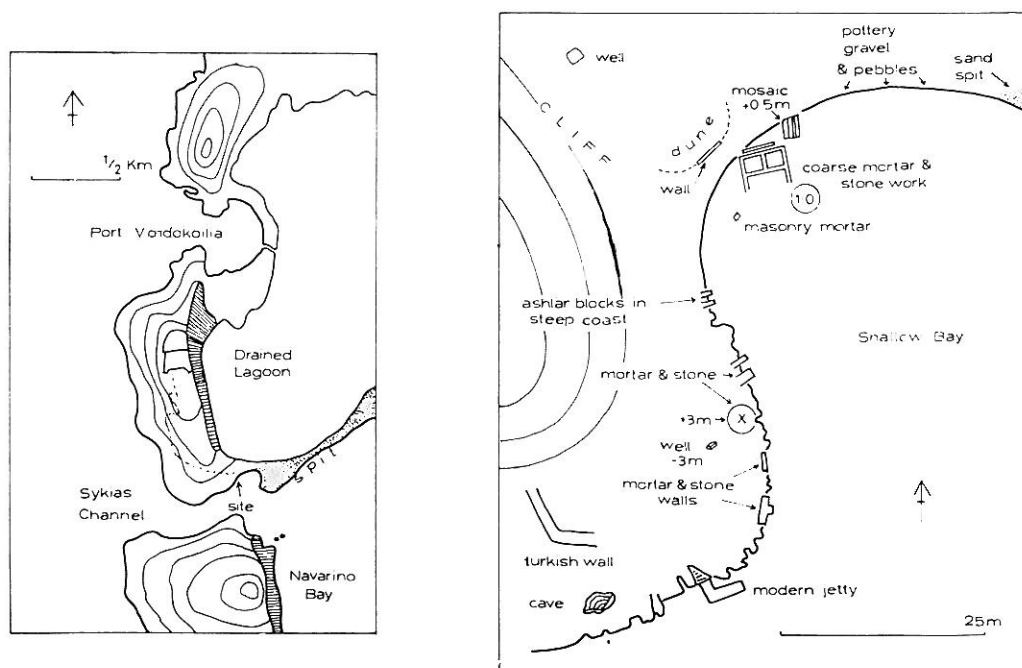

Figure 19. Pylus.

there are the foundations of a house or villa *in situ* in 1.0 m, and some scattered masonry in slightly deeper water. There is indication of submergence by 1.5 m since the Roman period.

PHEA. Katakolon. 37° 38' N., 21° 20' E. Chart 270.
Strabo 8.3.12. Hall (1969).

This site has been surveyed underwater by J. Hall of the University of Miami, who has reported that there are walls *in situ* to depths of several metres and that a slump fault appears to cross the underwater site. Investigation in 1968 failed to locate these structures, but a number of ancient quarries with individual block cuttings along the shore indicated submergence by 1.0 m.

TURKISH COAST

Introduction

Conduct of the survey of ruins on the coast between Izmir and Cnidus was greatly assisted by previous discussion with D. J. Blackman, and we wish to express extreme indebtedness for the opportunity of consulting unpublished field notes.

ELAEA. Kazıkbağları, near Reşadiye. 38° 57' N., 27° 03' E. Chart 1617.
Strabo 13.1.67. Schuchhardt (1912, 111–13), Bean (1966, 112–14).

Bean (1966) described the early Hellenistic mole, and shows a photograph of it projecting from mud and shallow water. Blackman (personal communication) reports that the mole is at least 204 m long, with keyed blocks bevelled on the outer edge to protect the joints. The mole rises 20–40 centimetres above water level, but the top courses are missing. There is very little evidence for a change of level here, though there may have been slight submergence.

CYME. Namurt Limanı. 38° 46' N., 26° 56' E. Chart 1617.
Strabo 13.3.3,6. Schäfer & Schläger (1962), Bean (1966, 103–6).

Schäfer and Schläger (1962) describe a mole of carefully laid blocks, of which the earliest period of construction may be of the sixth century B.C., with additions continuing into Roman Imperial times. From a cross-section of this mole they calculate (p. 53) that the water level change has been 1.60 m, on the assumption that cut blocks were not laid in regular courses below water level. Blackman (personal communication) considers that this assumption is not valid, and that therefore the relative change of the level is of the order of only 1.0 m.

(OLD) SMYRNA. Bayraklı, near Izmir. 38° 28' N., 27° 11' E. Charts 1645, 1522.
Strabo 14.1.37. Cook (1959).

Cook (1959, 9) discovered that the level of remains of the beginning of the second millennium B.C. was 3 m below sea level. The level of the fifth century B.C. was depressed relative to sea level by 1–2 m (1959, 11).

CLAZOMENAE. Urla Iskelesi, Karantina Adası. 38° 22' N., 26° 48' E. Chart 1645. Pausanias 7.3.9. Strabo 14.1.36. Cook (1954), Bean (1966, 128–36). Figure 20.

The Hellenistic causeway to the island is parallel to the modern road, and extends 20 m in width out from the road on the western side beneath the water. The causeway appears to have consisted of a rubble bank upon which were laid facing-walls of stone and mortarwork, including some large well-cut blocks. The western facing-wall is now flush with the water level, with blocks projecting in places, and the area within the walls which would have included the road surface is submerged by 1–2 m. The road surface is missing, and the height of this above the rubble or the base of the facing-wall is uncertain. It seems probable that the rubble bank originally reached to or above

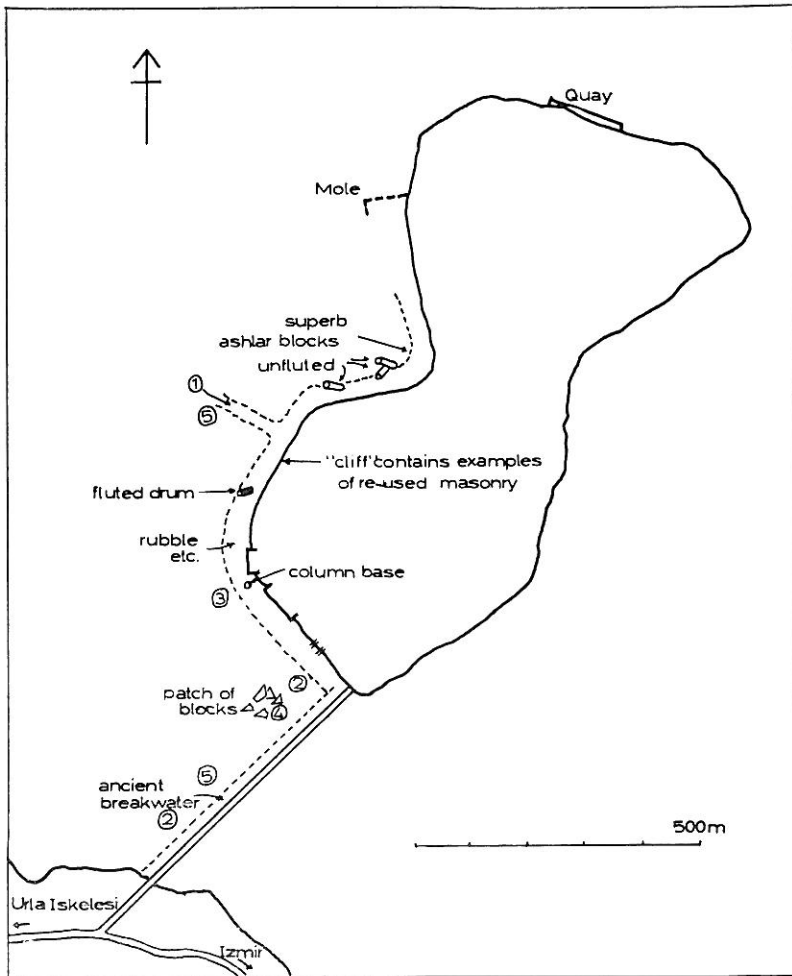

Figure 20. Clazomenae.

the water level, and that submergence has therefore been of the order of 1.0 m. The south and west sides of the island are fringed with rubble and cut blocks, including several column-drums, but no detectable foundations *in situ*. Two rubble moles project westwards, with their upper surfaces submerged by 1–2 m in a total water depth of 5 m. The southern mole has a very flat top and straight sloping sides, suggesting that its original form has been preserved.

URLA BEACH (modern name). 38° 19' N., 26° 41' E. Chart 1645. Figure 21.

An old road on the beach parallels the modern one for a distance of 1 km at Urla Beach. The road surface of roughly-cut blocks is awash by 20–25 cm, and broken by the waves in many places. There are two bridges spanning small stream beds, with their piers partly in the sea and partly embedded in the sand of the beach. The road appears to be several hundred years old, and to have been submerged by about 0.5 m since its construction.

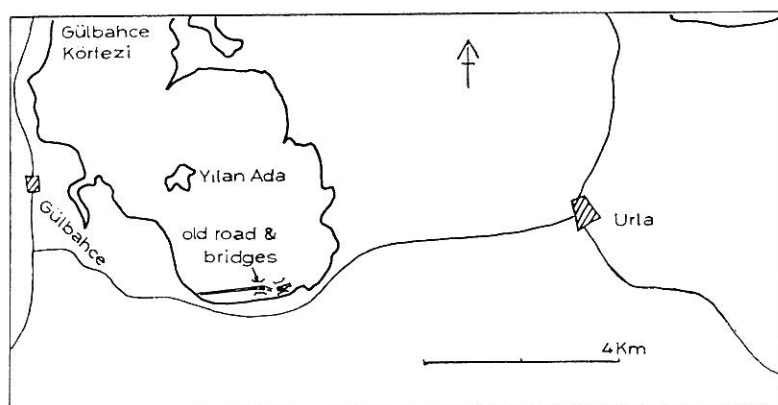

Figure 21. Urla Beach.

ERYTHRAE. Ildir. 38° 23' N., 26° 30' E. Chart 1645.

Strabo 14.1.31. Weber (1901), Roebuck (1959, 14–15), Bean (1966, 153–9). Figures 22 and 23.

The harbour was probably in the back of the bay where the stream enters the sea. There are some walls in the marshes, and a small mole 5 m broad just breaks the water on the south side of the stream mouth. Further along the shore on the south side of the bay there are cart ruts in the solid rock, now awash, and some beach rock in a depth of 1.5 m. Where the road through the present town of Ildir comes down to the sea there is an extensive area of ruins in the water. The modern track which continues round the headland to the north-west is partially protected with rows of uncut stones, but nevertheless is awash in places, showing evidence of continuing submergence. On the shore below the circular tower there are a number of house-foundations between the track and the sea. The most modern foundations have a floor level only 20 cm above the water, and appear to have been abandoned within this century. Below this layer, and extending

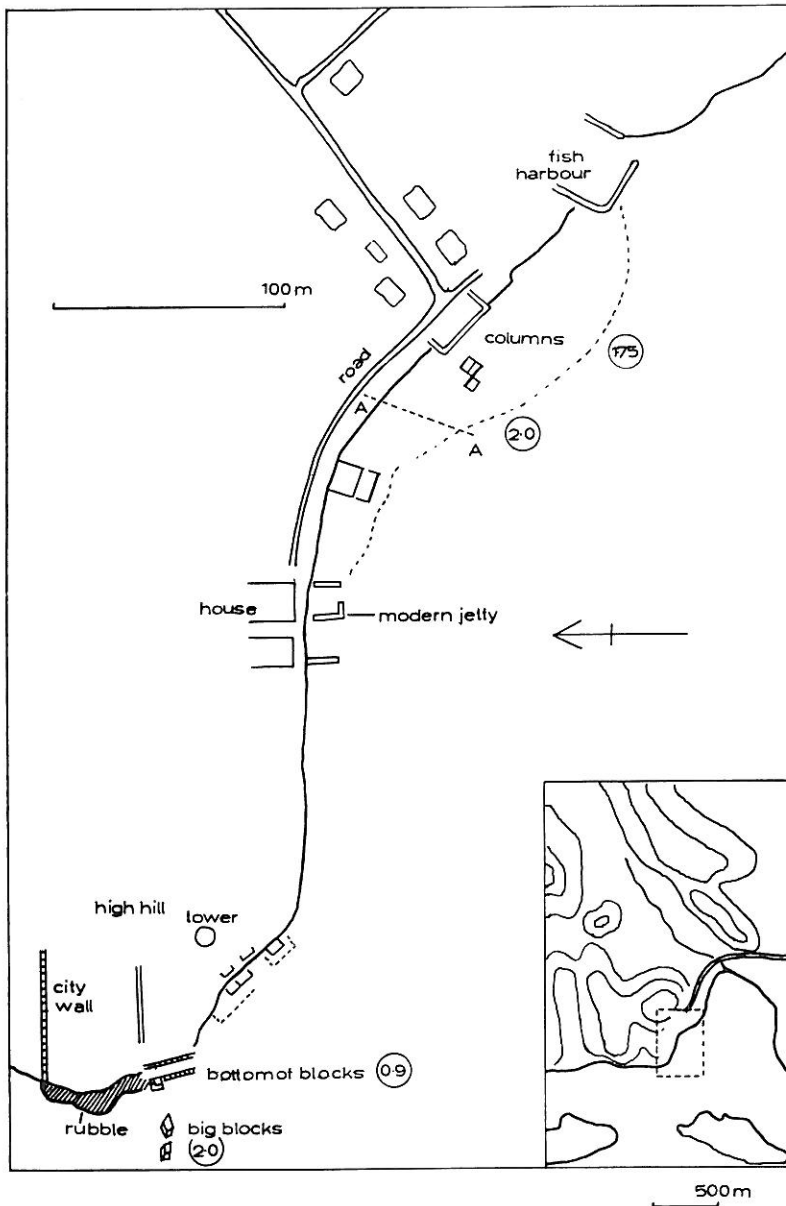

Figure 22. Ildir.

several metres further seawards, are foundations with floors at -20 cm, probably several centuries old. Further round the headland to the north are two parallel lines of cut blocks in 90 cm of water, suggesting an ancient roadway or possibly the seaward wall of the ancient city.

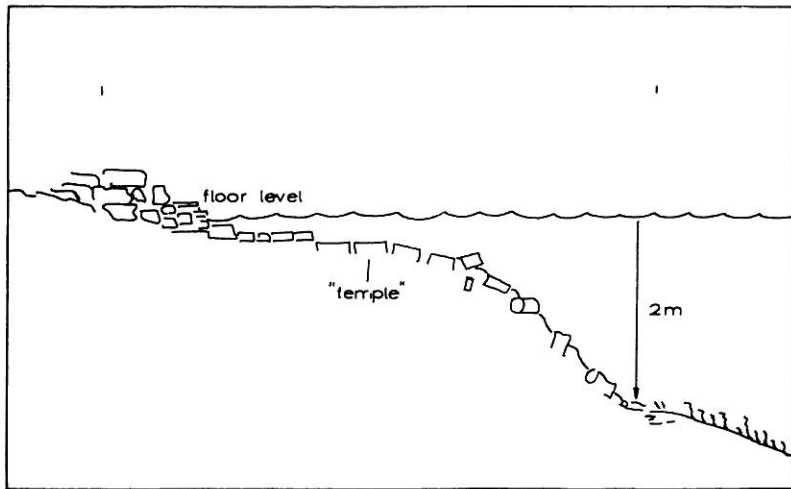

Figure 23. Ildır. Profile A-A.

The section AA on Figure 22 is represented in Figure 23. There is a floor at a depth of 0.5 m, which is broken apart at the brink of a rubble slope which descends to 2.0 m. At the landward edge there are the remains of houses with floor levels just above the present water level. In the shallow water and on the rubble slope there are the remains of a building of some importance: six column-drums of 80 cm diameter and 1 m length; four column-drums of 30 cm diameter; two column-drums of 40 cm diameter, with a bevelled lip at one end; one column-drum of 40 cm diameter and 60 cm length, bevelled at both ends; several carved architraves, fluted column-bases, and rectangular blocks carved with raised keys or recessed slots. The floor level of this building was certainly raised above the ground, and this, combined with the road or wall-foundation now at a depth of 90 cm, indicates submergence of about 1.5 m.

YALI (modern name). 38° 20' N., 26° 26' E. Charts 1645, 1087. Figure 24.

No charts or maps of this piece of the coast are accurate. The name given for the group of houses may be only of local use, as it is not marked on the maps. The track through the village terminates at the shore at a point where a field-wall protects a projecting area of land from immediate erosion. Beyond this wall, in a depth of 0.5 m, is an area of several house-walls of rough mortar and more square stones with some ashlar. There has probably been submergence by half a metre since medieval times.

ILICA (modern name). 38° 20' N., 26° 22' E. Chart 1645.
Cook (1959, 21), Bean (1966, 159). Figure 25.

Bean (1966) states that there was no ancient city at Ilica, but that it was the site of important thermal springs. Cook (1959) dates pottery on the site to the fourth century B.C. An unsurfaced road leads from the village along the east shore of Kalem Burun, where there are a number of small jetties for holiday boats. From the tip of the headland

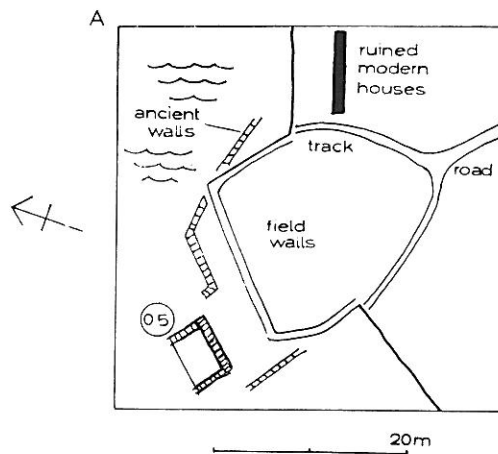
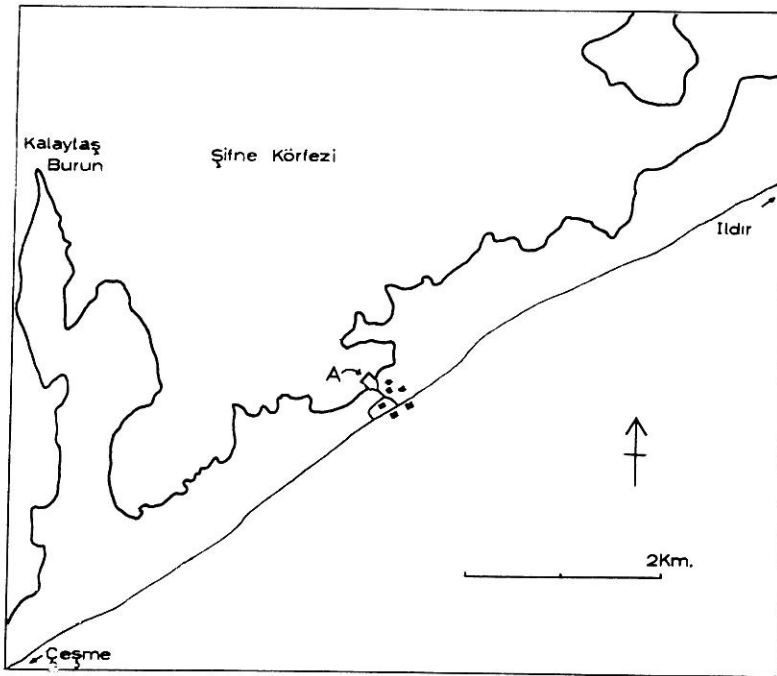

Figure 24. Yalı.

a submerged mole of rubble and cut blocks stretches eastwards, containing many pottery fragments in the interstices. After a gap of 100 m a similar mound extends further on the same alignment, the crest being submerged by half a metre. The water depth at the end of this breakwater is 2-3 m. It is possible that there has been submergence of about 0.5 m.

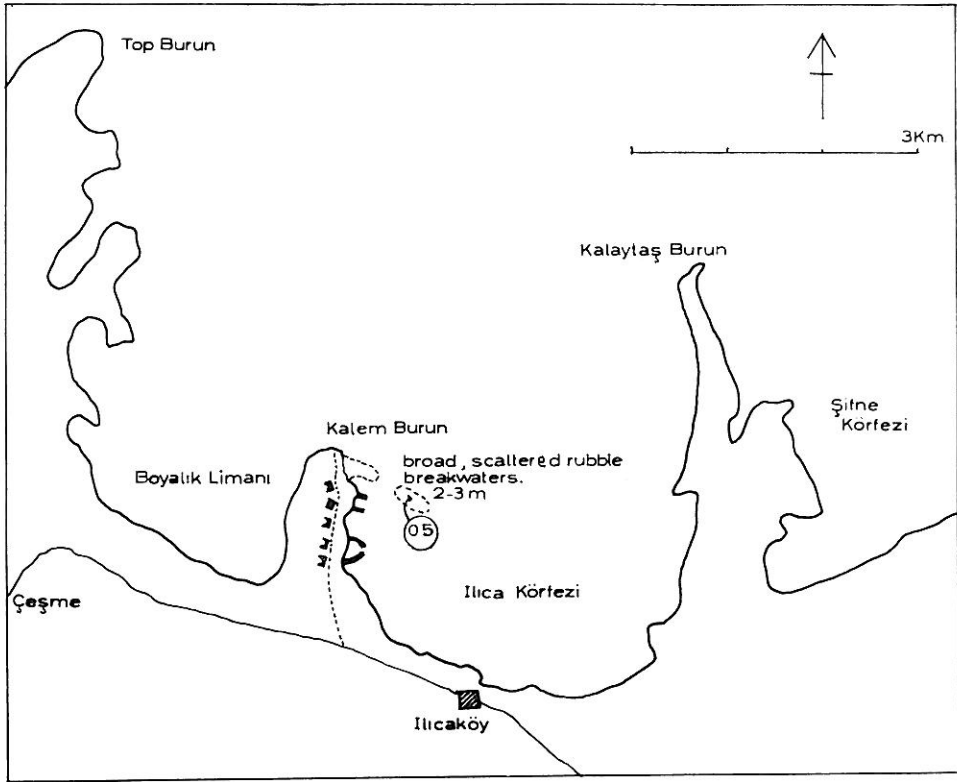

Figure 25. Ilica.

ÇEŞME (modern name). $38^{\circ} 20' N.$, $26^{\circ} 19' E.$ Chart 1617. Figure 26.

Where the road leaves the town to the south and passes round the bay, there is a broad expanse of mud-flats and shallow water. A wall of cement and uncut stones forms a square of side 20 m, extending into water 20 cm deep. This does not appear to have been a fish-tank or salt-pan, and therefore indicates a submergence of about 20 cm in the last few hundred years.

ÇİFTLİK (modern name). $38^{\circ} 18' N.$, $26^{\circ} 17' E.$ Chart 1645. Figure 27.

The village of Çiftlik is partly abandoned. South of the jetty, field- and garden-walls project into the sea and are being broken by the waves. North of the jetty, a field- or house-wall stretches towards the river mouth in a depth of 20 cm of water. The jetty

extends 50 m seawards and consists of walls of cement and uncut stones infilled with gravel. The ends of the walls are broken, and the sea is washing out the gravel. Beyond this there are the remains of a much older mole almost completely destroyed by the sea. There is clear evidence of continuing submergence, with a change of about 10 cm in the last hundred years.

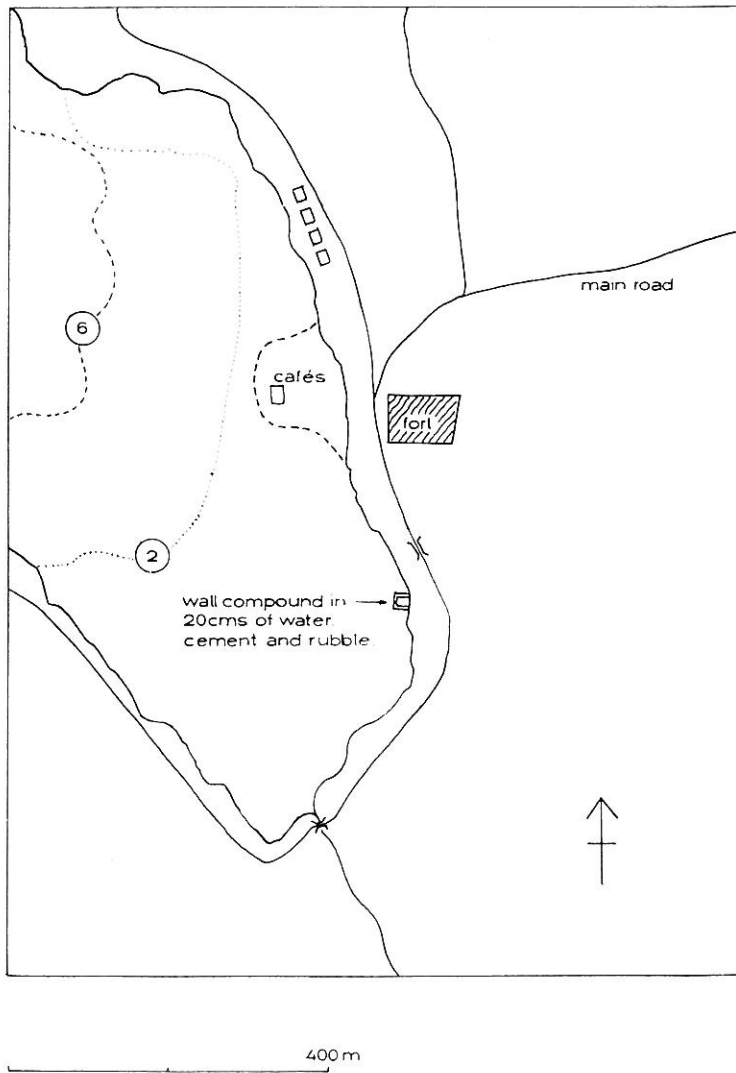

Figure 26. Çeşme.

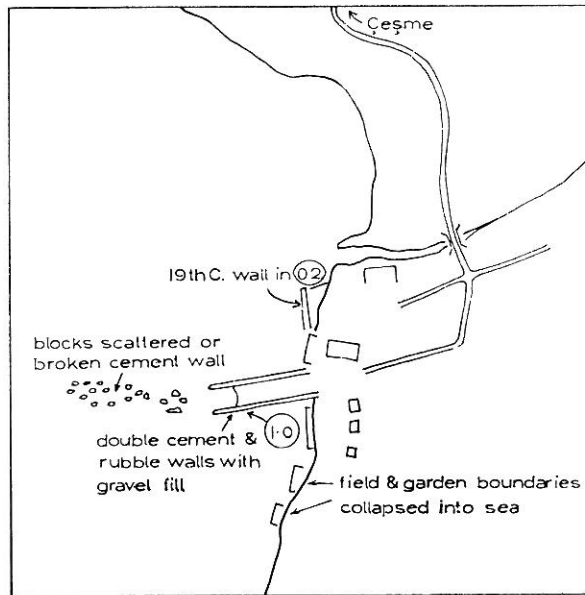

Figure 27. Çiftlik.

TEOS (northern harbour). Sığacık. $38^{\circ} 12' N.$, $26^{\circ} 48' E.$ Chart 1606. Strabo 14.1.29–30. Béquignon & Laumonier (1925, pl. VII), Bean (1966, 142). Figure 28.

This bay was the northern harbour of Teos. A pathway at the level of the modern quay extends round the walls of the fortress, set with small mooring-rings. A submerged mole consisting of two small walls of ashlar projects into the bay from the seawardmost point of the castle. The difference of level between the modern and ancient jetty surfaces is 80 cm. Another wall of ashlar projects from the western corner of the present quay. These structures indicate a change of 50–80 cm since the classical period. In the mud-flat south-west of the quay there is a disused road, which would be covered by the sea if the level rose only a few centimetres in an onshore wind. This suggests a relative submergence of about 10 cm in the last hundred years.

TEOS (southern harbour). South of Sığacık. $38^{\circ} 11' N.$, $26^{\circ} 48' E.$ Chart 1645. Strabo 14.1.29–30. Béquignon & Laumonier (1925), Bean (1966, 140–2 & pl. 21). Figure 29.

The walls of the Hellenistic city extend down to a quay protected by a spit of rock and sand at the river mouth. At its western end the quay has subsided completely into the water, but at its eastern end the facing, upper surface, and mooring-stones appear to be *in situ*. The mooring-stones are separated from one another by 3 m, and the centre of the mooring-hole is 20 cm above the present waterline, while the lower edge of the stones is awash. A section of ashlar wall continues to the end of the spit, and breaks off into the water. Rocks projecting from the water on the outer side of the spit give the appearance of masonry, but are all bedrock. If we assume that the centre of

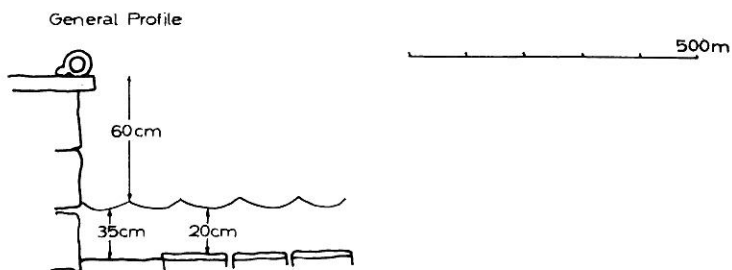
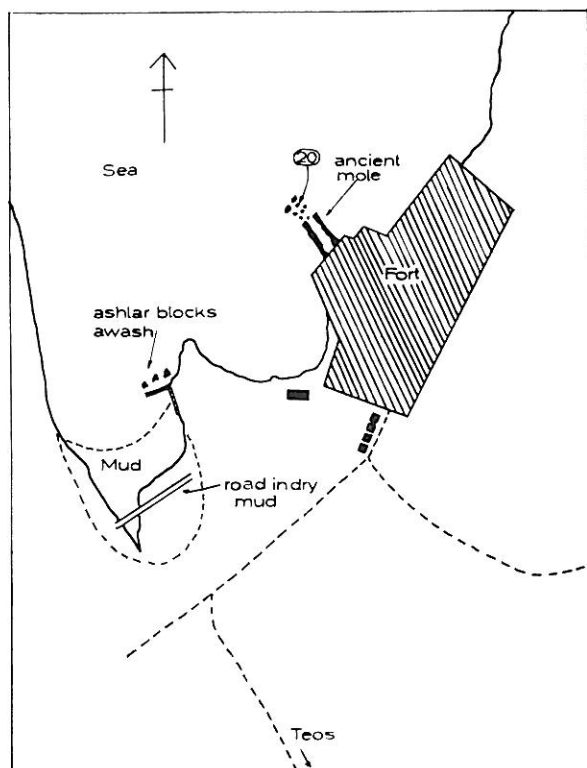

Figure 28. Sığacık.

the mooring-rings was originally 1.0 m above the water (compare Leptis Magna: Bartoccini and Zanelli, 1958), the relative change of level has been 80 cm.

LEBEDUS. Kısıık. 38° 05' N., 26° 59' E. Chart 1645.
 Bean (1966, 151-3).

The circumference of the peninsula was searched, but no signs were found from which possible changes of sea level could be deduced.

B*

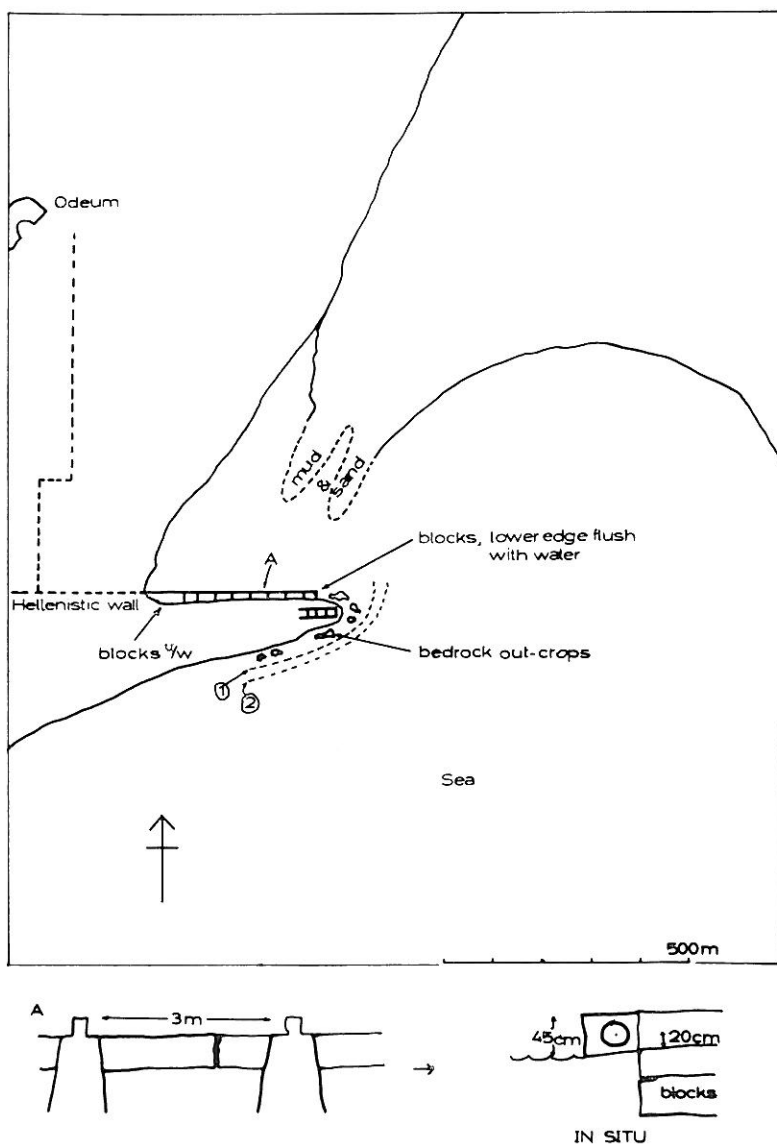

Figure 29. Teos.

NOTIUM. Near Ahmetbeyli. 38° 00' N., 27° 13' E. Chart 3346. Demangel & Laumonier (1923), Bean (1966, 188-90). Figure 30.

The city of Notium is on the summit of the hill on the east side of the valley overlooking the sea. There are steep cliffs and no ruins on the shore. The temple of Claros is 1 km inland in the alluvial river plain; it has, since its construction, been overwhelmed by about 5 m of sediment so that the foundations are at least 1 m below the summer

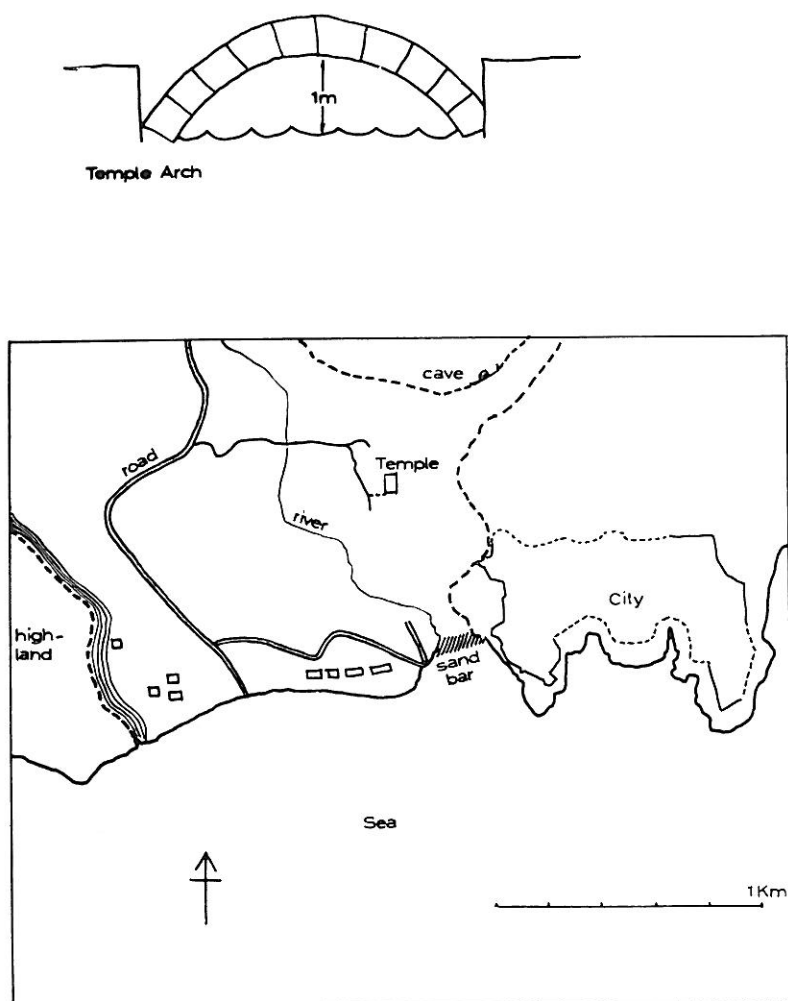

Figure 30. Notium.

water-table. The rise in water-table is partly accounted for by the extension seaward of the river mouth, but it may include a factor due to relative sea level change. The original shoreline was much nearer the temple, and the remains of any harbour constructions are now buried in silt. No conclusions can be made from the present evidence.

EPHESUS. Near Selçuk. $37^{\circ} 56' N.$, $27^{\circ} 20' E.$ Chart 3346.

Pliny, *N. H.* XXXVI. 95. Hogarth (1908), Bammer (1965), Bean (1966, 160–84).

The city of Ephesus is now 7 km from the sea, and the harbour is completely silted up. The principal religious site was the temple of Artemis; it has also been covered by silt, and its foundations are below the modern water-table. Bammer (1965, 126) states

that the foundation of the eighth-century B.C. temple lies only 0.6 m above the present sea level. In contrast, the late classical temple was built 2.74 m above present sea level. From this evidence Bammer argues a rapid rise of sea level in the intervening period. While this is not totally impossible, it is probable that the earlier building has indeed been submerged relative to present sea level by $\frac{1}{2}$ –1 m, and that the later building was constructed higher for purely architectural reasons. The present level of the water-table is not the same as sea level, owing to the distance from the sea.

MILETUS. Balat. 37° 32' N., 27° 18' E. Chart 1546.

Strabo 14.1.6. von Gerkan (1935), Kleiner (1966), Bean (1966, 219–30).

Miletus is now 4 miles from the sea, though it was originally a port. von Gerkan (1935) states that the relative rise of sea level has been 1.5 m since Greco-Roman times. Kleiner (1966) reports Mycenaean levels at and slightly below the ground water level. The change of level since Mycenaean times would probably be more than that since Greco-Roman times.

HERACLEIA UNDER LATMUS. Kapıkırı. 37° 30' N., 27° 33' E. Chart 1546.

Strabo 14.1.8. Leake (1824, 237–9), Bean & Cook (1957, 138–40), Bean (1966, 252–8). Figure 31.

Heracleia under Latmus was originally on the sea coast in a deep inlet, but the silt from the Maeander has closed the entrance and formed a lake. At the moment it is not possible to deduce relative changes of level from this site, on account of variations in level of the lake, and the absence of levelling from the lake to the sea. There are ashlar walls in the water between the main city and the island, although these do not appear to link the island to the city circuit. The much later walls on the island itself do not descend below water level. North of the island, on the side of a rock outcrop projecting from the water, is a Carian-type rock-cut grave with its floor at a depth of 1.45 m. Around the necropolis headland there are at least seven graves submerged to depths of 1.45–1.5 m. Erosion marks and encrustations of dried algae on rocks showed that the spring or winter water level was 60–70 cm higher than that observed in the summer.

GHIOURKERI ISLAND (modern name). 37° 29' N., 27° 31' E. Chart 1546. Figure 32.

The island is about 100 m from the south shore of Lake Bafa, opposite Heracleia under Latmus. Between the mainland and the island are two parallel walls in 1.5 m of water, and an arch with the centre of the vault only 37 cm above the water. These ruins, which are presumably associated with the Byzantine fortified monastery on the island, are immersed by at least 1.7 m.

PANORMUS. Kovala Limanı. 37° 24' N., 27° 15' E. Chart 1546.

Pausanias 5.7.5. Newton (1863). Figure 33.

There was an important temple at Didyma by the sixth century B.C., and the vast temple of Apollo which can still be seen was started in 332 B.C. The pilgrims arrived at the temple by way of the harbour at Panormus and thence along a ceremonial road 6 km in length. About 80 m from the shore the top of a column-drum 2 m in diameter and 2 m in length projects from the water. Two other drums lie nearby on their sides. These materials were probably abandoned at some stage during the construction of

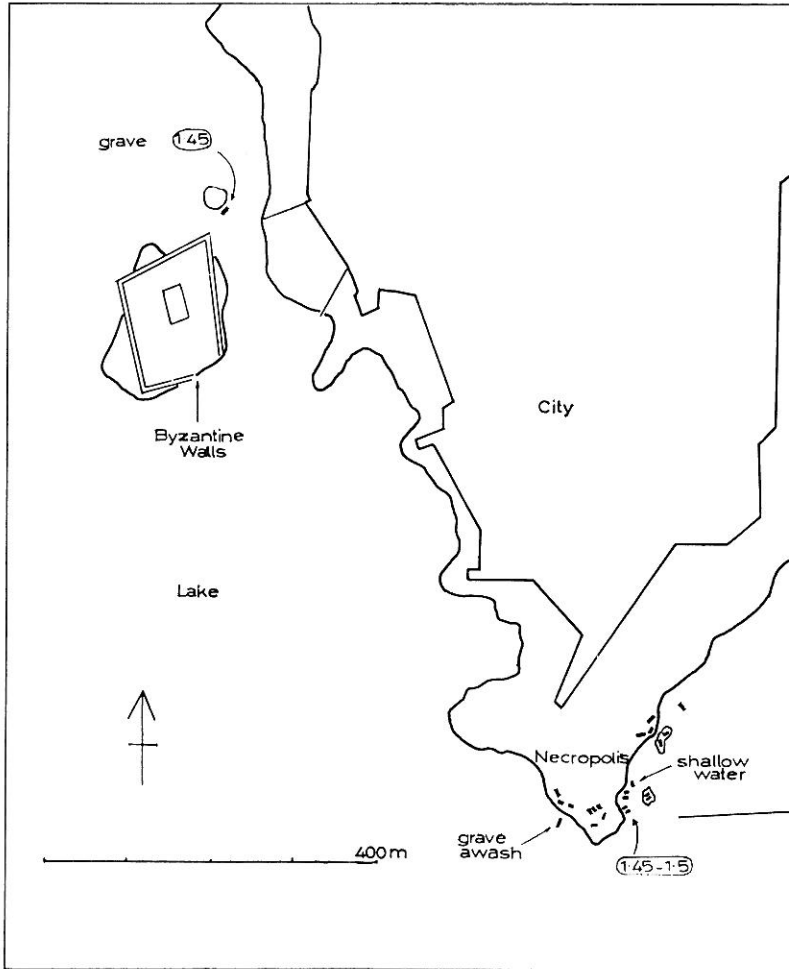

Typical Grave

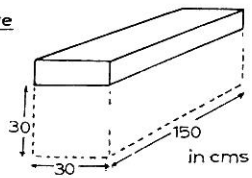

Figure 31. Heracleia under Latmus.

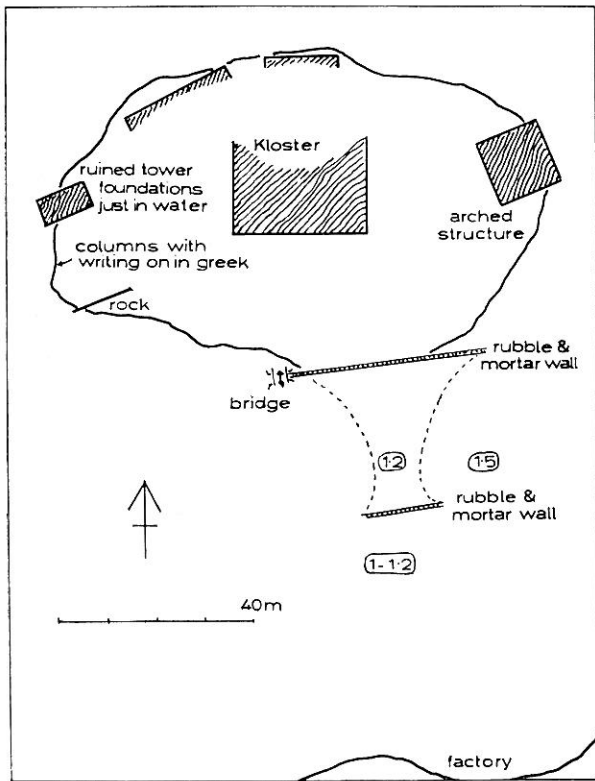
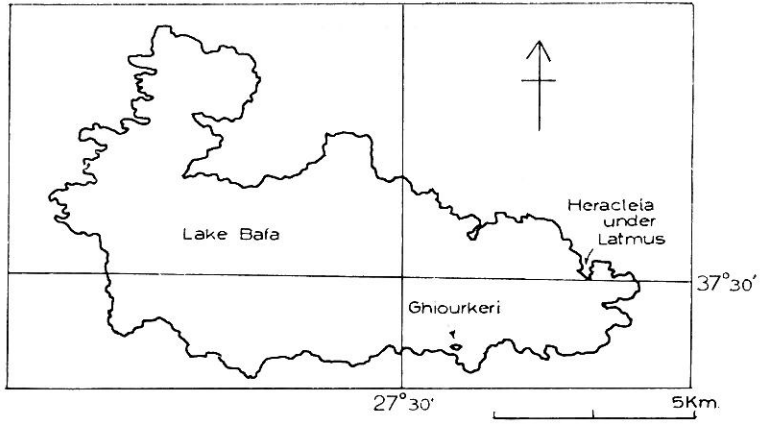

Figure 32. Ghiourkeri Island.

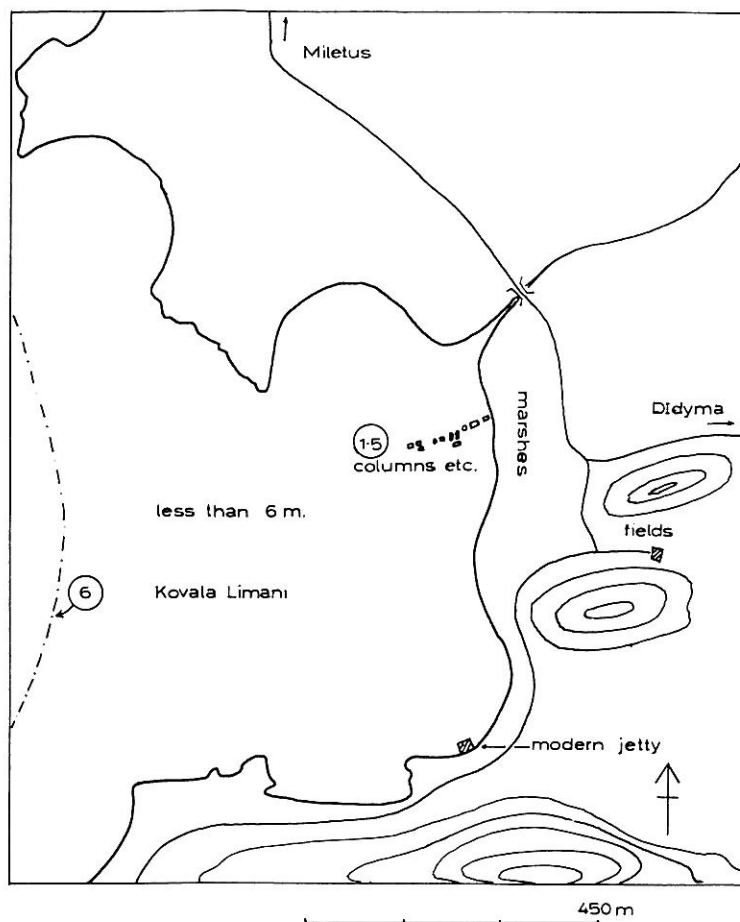

Figure 33. Panormus.

the temple at Didyma, which was never completed. The drums lie in a continuous line with a number of large blocks, 2 by 1.0 by 1.5 m, which are submerged at their upper surface by 20–50 cm, and patches of scattered rubble. The depth at the end of the line, 130 m from the shore, is 1.5 m. Owing to the shallowness of the bay there must have been jetties at which the pilgrims and cargoes were disembarked, but nothing substantial remains. The column-drums were probably unloaded on to a jetty and left on the surface, or dropped in the water near the jetty. It is probable that there has been little silting, because the columns are still exposed; and the jetty must have extended into at least 1–1.5 m of water, so that there can have been little change of water level. Owing to the uncertainties of this site, movement could have been anything between +50 and –50 cm.

IASUS. ASIN Kale. $37^{\circ} 17' N.$, $27^{\circ} 37' E.$ Chart 1606.
 Strabo 14.2.21. Bean & Cook (1957, 100-05). Figure 34.

The rubble mole on the west side of the bay is awash to a depth of 50 cm, but has no foundations on it. The mole on the east side has a single course of ashlar, with its upper surface just awash, resting on the rubble. At the end of this mole there is a medieval fort with its foundations at water level, but the floor is considerably raised. At the tip of the headland there are walls of ashlar seriously undermined by the waves, and on the west side a row of large blocks submerged by 10 cm, suggesting a roadway along the shore. At many points medieval walls come to the beach and stop, or run parallel to the shore, but at no point are walls of this period submerged. Therefore there has been a change in level of 50 cm since the Greco-Roman period, but very little change since medieval times.

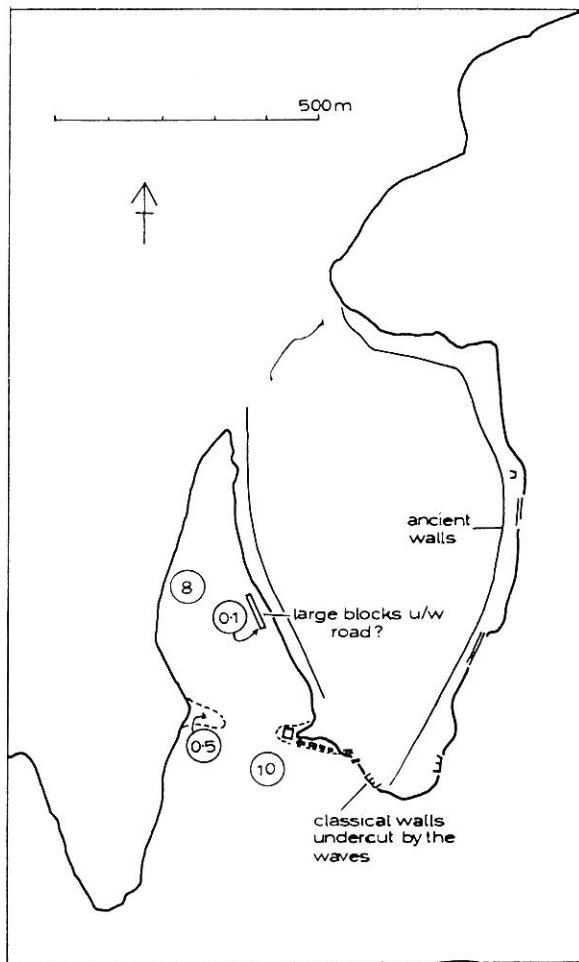

Figure 34. Iasus.

BARGYLIA. Varvil, Asar. 37° 12' N., 27° 38' E. Charts 1546, 1531.
Polybius 16.24. Leake (1824), Bean & Cook (1957, 96-7). Figure 35.

The harbour has silted up and the mole from the city across to the east side has partly collapsed into the water. This causeway has been continuously remade and repaired, though part is now broken, and it is not possible to deduce any change of level or date from it. The bay to the south of the city dries out as a mud-flat in summer. There are a number of small indentations off the shore facing the mud, and flush with the surface of the mud are various walls and fragments of foundations. Before the bay

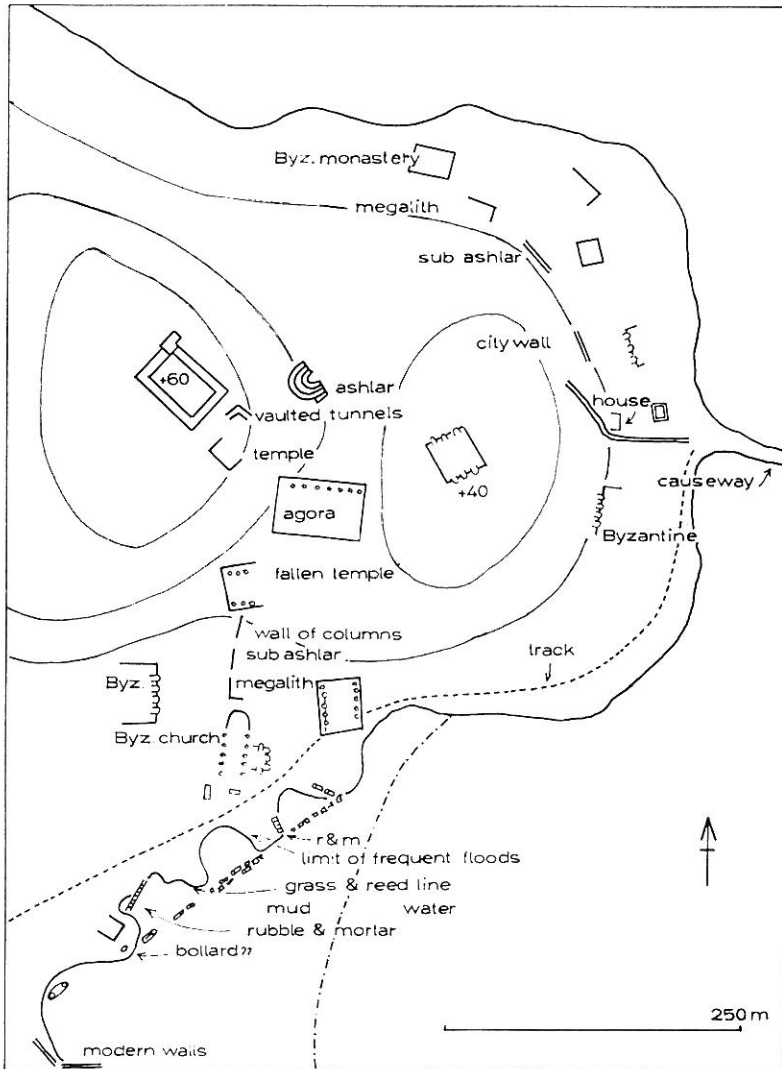

Figure 35. Bargylia.

silted up, this area would have provided a very sheltered quay, and although pillaging may have removed the upper surface, there may have been submergence by about 20 cm.

CARYANDA. Güvercinlik. $37^{\circ} 08' N.$, $27^{\circ} 36' E.$ Chart 1546.

Leake (1824, 227–8), Bean & Cook (1957, 97). Figures 36 and 37.

The headland is scattered with ruins of many periods, including late Roman or Byzantine, medieval, and others up to the nineteenth century, while at the back of the bay there are large vaulted ruins near the beach. In the most sheltered corner of the bay is a broken mole with a paved surface of irregular flat stones resting on a broad bank of loose rubble. The paved surface breaks off before the end of the bank, and at this point (see Fig. 37A) there is an intricately carved architectural block which must have been acquired from a building of some importance. A submerged road fringes the northern side of the headland, marked by a row of uncut blocks 2–3 m seawards of the shore, or the same distance from foundations or walls in the water. Seawards of the road are two loose stone jetties with their upper surfaces submerged by 20 cm. The road is submerged by 10 cm, although the true surface may be missing. On the south side of the headland there are a number of rock cuttings and structures of unshaped stones in the water, but nothing clearly identifiable.

The submerged road and jetties and foundations in the water near the road indicate submergence of about 30 cm since late Roman times. The large mole with paved

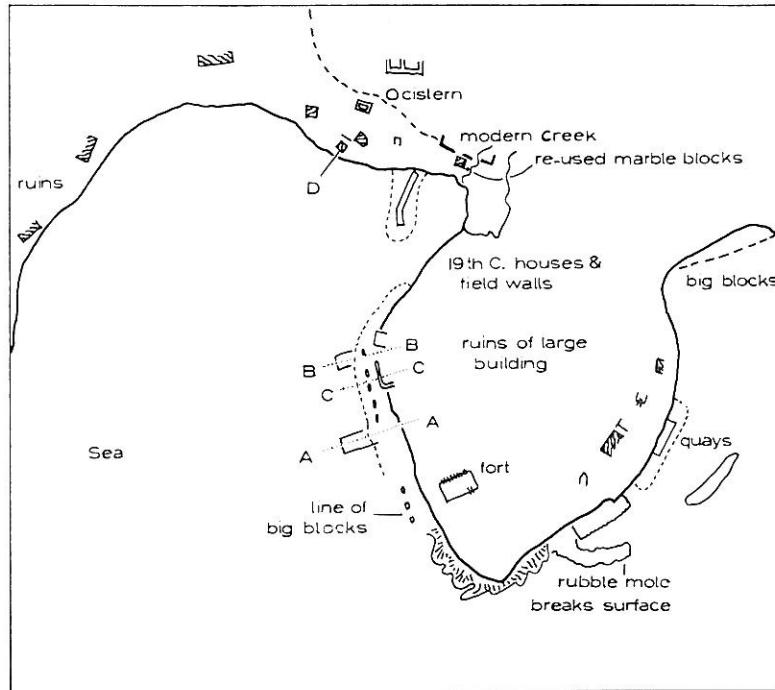

Figure 36. Güvercinlik. North to left.

Jetty

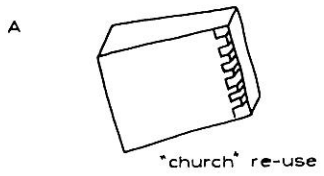
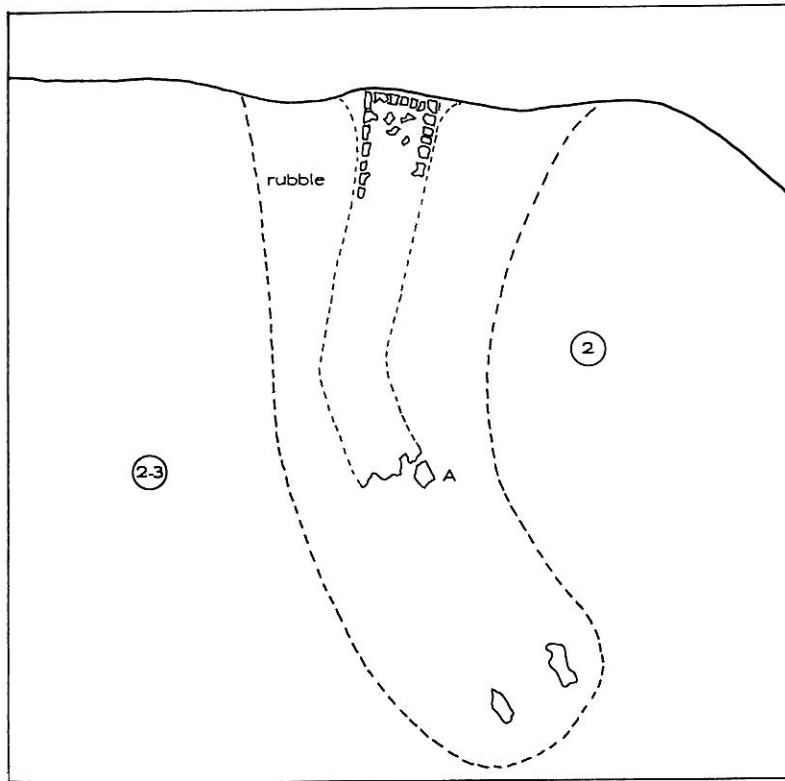

Figure 37. Güvercinlik.

surface has its upper surface complete in places and 20 cm above the water. The mole terminates clearly at the present shoreline. Although the rubble bank may be much older, the paved surface appears to be only a few hundred years old, and a change of level since its construction is not detectable.

GÖL (modern name). 37° 08' N., 27° 26' E. Chart 1546.
Newton (1863, 595), Bean & Cook (1955, 131). Figure 38.

Between Göl and Türkbükü there are tombs and quarries on the shore with cut surfaces awash to a depth of 20 cm. At Göl there is a small Christian church still standing, though much overgrown, and roadworks in 1969 revealed a number of marble columns

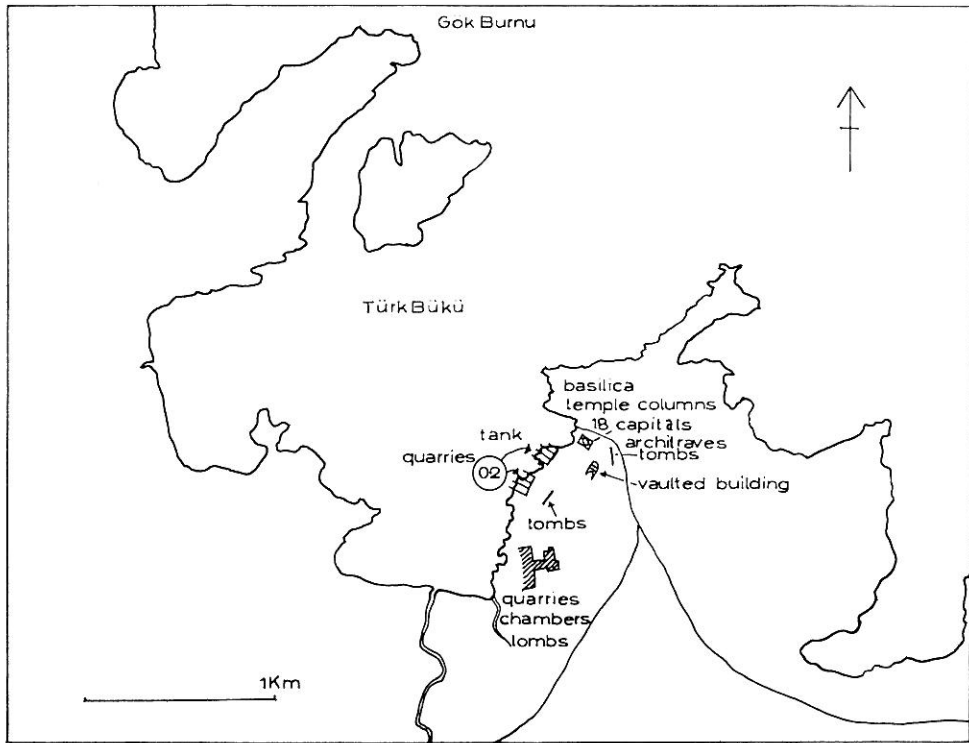

Figure 38. Göl.

and 18 capitals. Some parts of the same building are to be found built into local houses. There are Hellenistic remains on the hills behind. Because of the difficulties of dating the quarries no firm conclusion about changes of level can be reached.

MYNDUS. Gümüşlük. $37^{\circ} 03' N.$, $27^{\circ} 16' E.$ Chart 3924, 1531.

Strabo 14.2.18. Leake (1824, 228), Bean & Cook (1955, 108–11). Figures 39, 40.

On the north side of the isthmus there is a tower foundation with a paved floor flush with the water level over which the waves break. On the east side of the bay near the present village is a rubble mole with the surface 70 cm below the water. On Chart 1531, surveyed in 1837, the presence of a rectangular structure is marked on this mole. On the north side of the harbour entrance is a short rubble mole topped with two parallel walls of ashlar, terminating in a tower base of stepped ashlar construction. The upper surface of the tower is at water level, and the base at -2 m. On the south side of the harbour entrance there is a flight of steps descending the cliff to a rock-cut platform about 6 metres square and 1 m above the water. Along the northern shore of the island there is a broad fringing bank of rubble in the water, including cut blocks and some columns. Between the island and the mainland a curving shingle spit partly conceals Roman quays and breakwaters, and a number of later building foundations

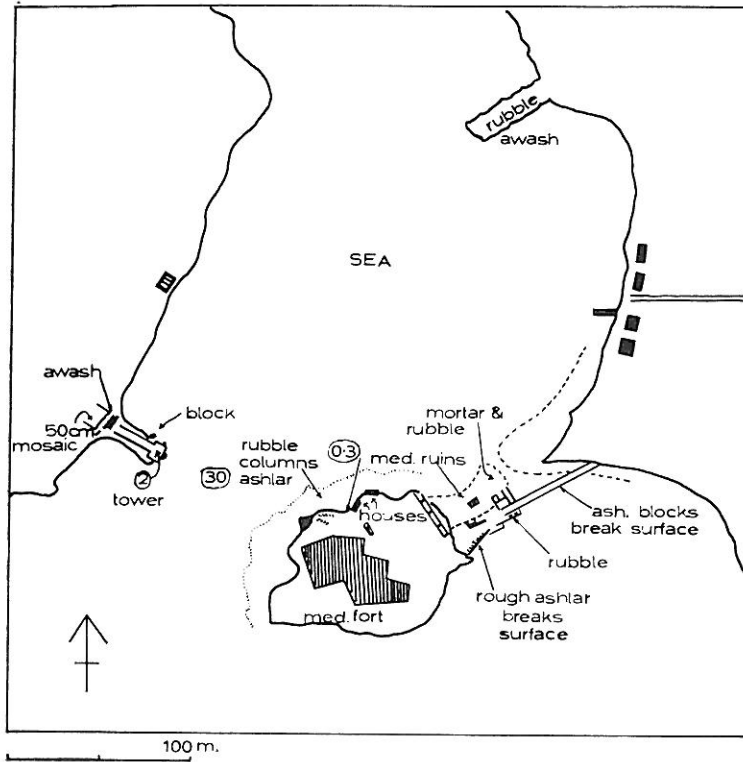
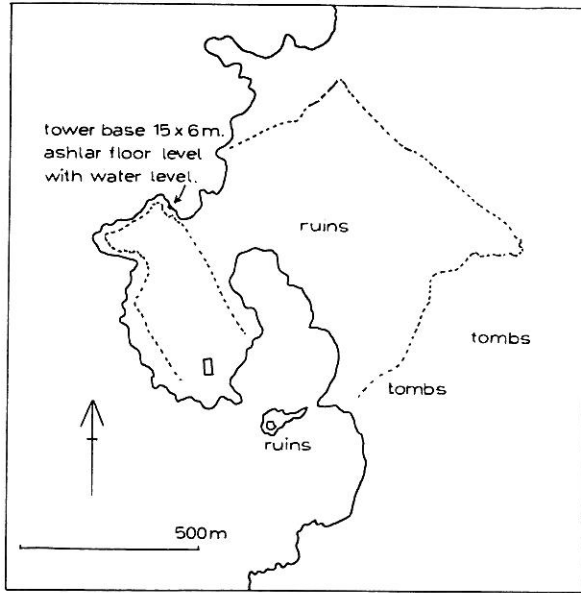

Tower



Figures 39, 40. Myndus.

in the water. The main quays of ashlar are heavily corroded on the upper surface, but the highest parts of the stones just project above the water.

When the site was visited in July 1969, waves were breaking over all structures near the shore, including the platform 1 m above the water on the south side of the harbour entrance. In view of the exposed position of this site it is probable that the main quay surfaces were slightly more than 1 m above the water.

KARATOPRAK (modern name). 37° 00' N., 27' 17' E. Chart 3924.
 Bean & Cook (1955, 128). Figure 41.

The road south from Karatoprak shows signs of erosion at many points, and there are also tombs and traces of early settlement in the area. There are no ancient remains *in situ* on the shore apart from a well or silo near the lighthouse. The floor surrounding the rim of this is 1 m above sea level. About 100 m north of the northern edge of Karatoprak (A on Fig. 41) the remains of a villa are largely buried by sand, but fragments of wall protrude into the sea. The walls are of rubble and white mortar with a thickness of 0.5 m. Some of the broken material has been piled up to make a small groyne or jetty, but the original walls *in situ* are still clearly visible, with the deepest structure a rectangular room partly covered by the jetty. There is a mosaic floor with a decorated

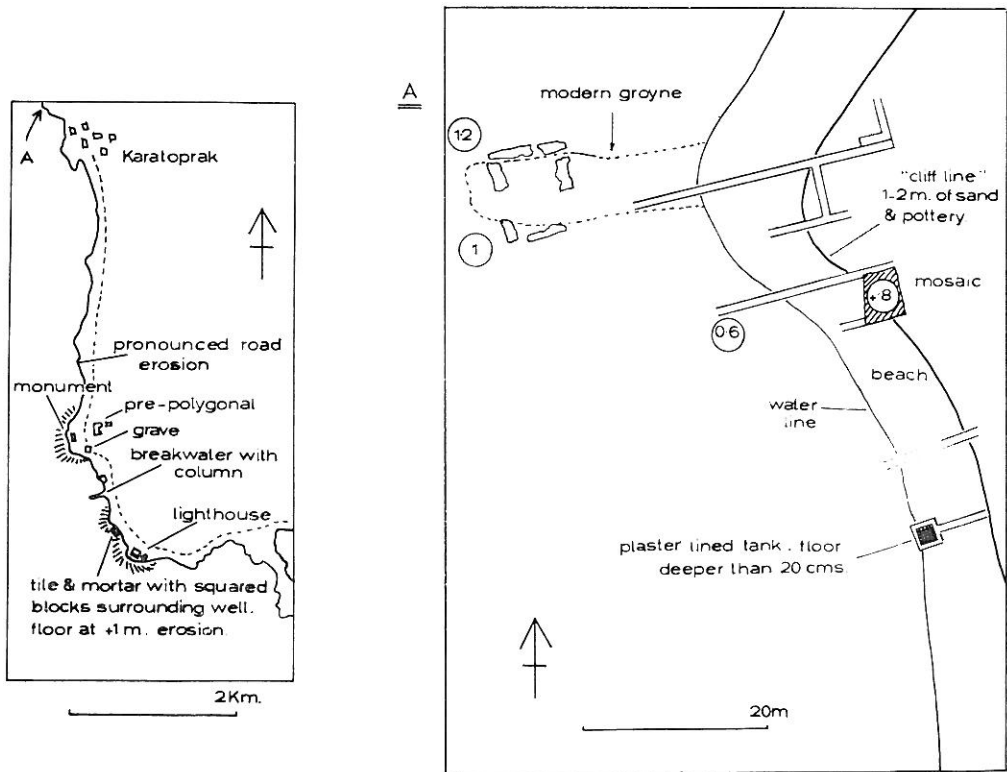

Figure 41. Karatoprak.

border 18 cm above water level. The two long walls running into the water are definitely *in situ* where they are on the dry beach, but in the water they slope seawards with the beach, as if they had been undermined. Thus they may not originally have been based at exactly this level. On the other hand, the rectangular walls at the end of the jetty appear to be exactly *in situ*, and the foundations of the walls on the beach must descend at least to the water level, if not 20 cm below. Thus the change is of the order of 0.5–1.0 m.

HALICARNASSUS. Bodrum. 37° 02' N., 27° 27' E. Chart 1606.
Strabo 14.2.16–7. Newton (1863), Bean & Cook (1955, 85–97). Figure 42.

In the north-east corner of the harbour is a submerged rubble mole supporting two ashlar tower foundations. The upper surface of the mole varies from 0.5–1.0 m in depth, while the ashlar upper surface is 40 cm under water. On the west side of this mole is a second parallel rubble wall separated from it by a water base about 5 m wide. The whole structure stands in 2–3 m of water. From the presence of the ashlar foundations and the fact that the narrower rubble wall could not be built any higher on the existing width of the base, it seems that the upper surface of the mole is intact. There may have been a paved surface, but that would not have raised the level more than 10 cm. Thus submergence is about 1.0 m.

CEDREAE. Taşbükü. 37° 00' N., 28° 14' E. Chart 1533.
Bean & Cook (1957, 64–5). *Mediterranean Pilot*, Vol. 4 (1918) 339. Figure 43.

The earliest pottery found on the island is of the fourth century B.C. and most of the surviving foundations are Hellenistic, Roman or Christian. On the northern shore of the eastern limb of Castle Island are a number of ruins, including a church with three apses, with foundations in a depth of 10–60 cm of water. The footings of the walls of the church are exactly at water level, and a quay surface between the apses and the water is 20 cm above water level. A mole projecting northwards is submerged by 50 cm, though the upper surface is not intact, and the foundations of it are awash. Since some of the deeper foundations may have been built in shallow water, it is probable that the actual sea level change has been 30 cm.

OLD CNIDUS. Datça. 36° 44' N., 27° 44' E. Chart 1604.
Bean & Cook (1952). Figure 44.

On the north shore of the bay 1 km north of Datça there is a considerable area of remains. On the landing beach there are some medieval walls and cisterns. Further round towards the headland of Dalacak, there are walls in the water which appear to enclose two small harbour basins. The masonry is trapezoidal in profile, but the interior surfaces of the blocks are quite irregular. The depth of water beside the easternmost jetty and in the entrance to the eastern basin suggests that there has been no change of relative level. At the tip of the headland is a small hook-shaped promontory enclosing a rectangular basin with a water depth of 1.0 m, and an entrance sill at 0.80 m. This may have been a fish-tank. North of the headland is more trapezoidal masonry of the fifth–fourth century B.C.

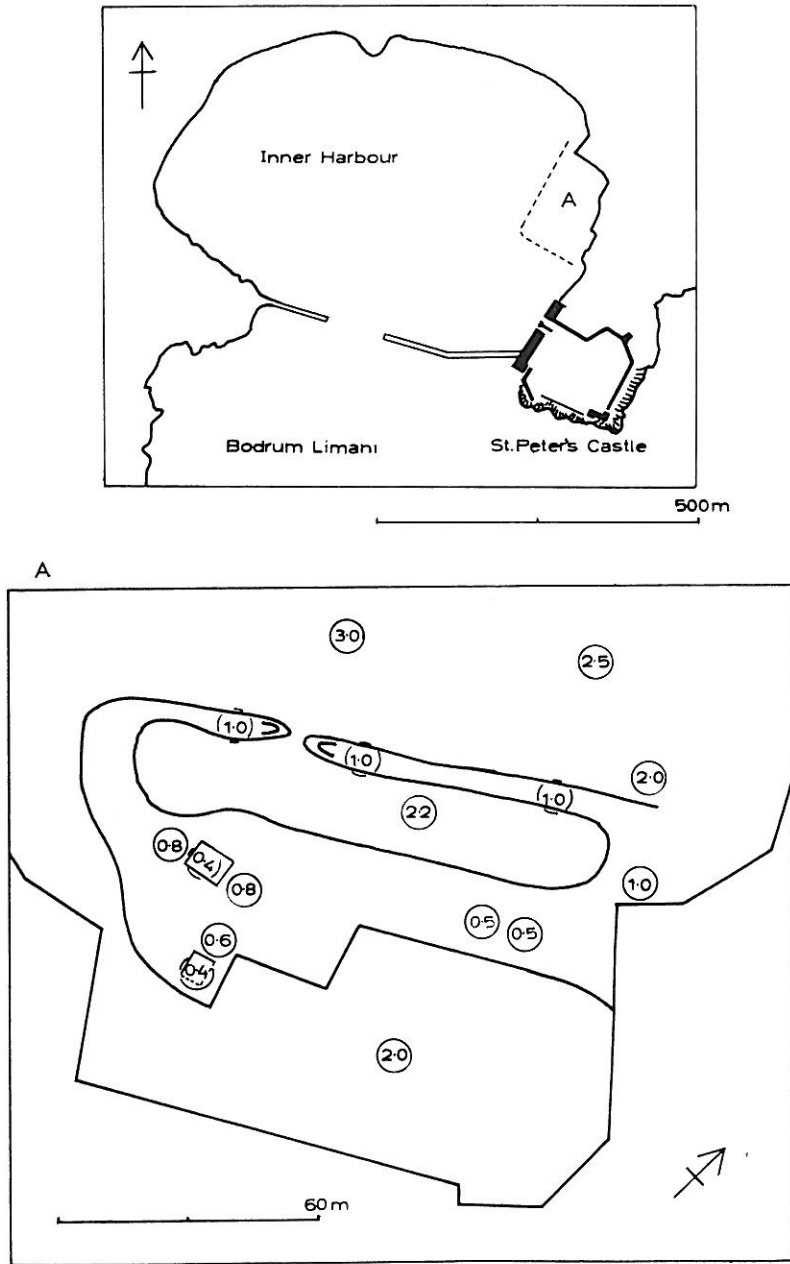

Figure 42. Bodrum.

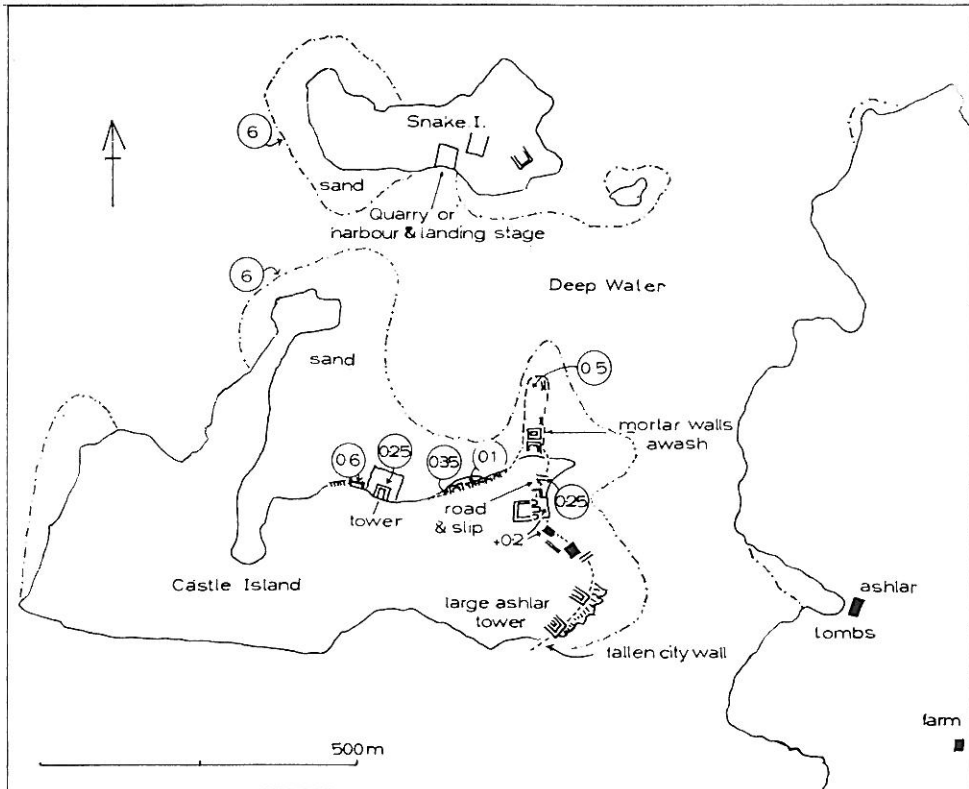

Figure 43. Cedreae.

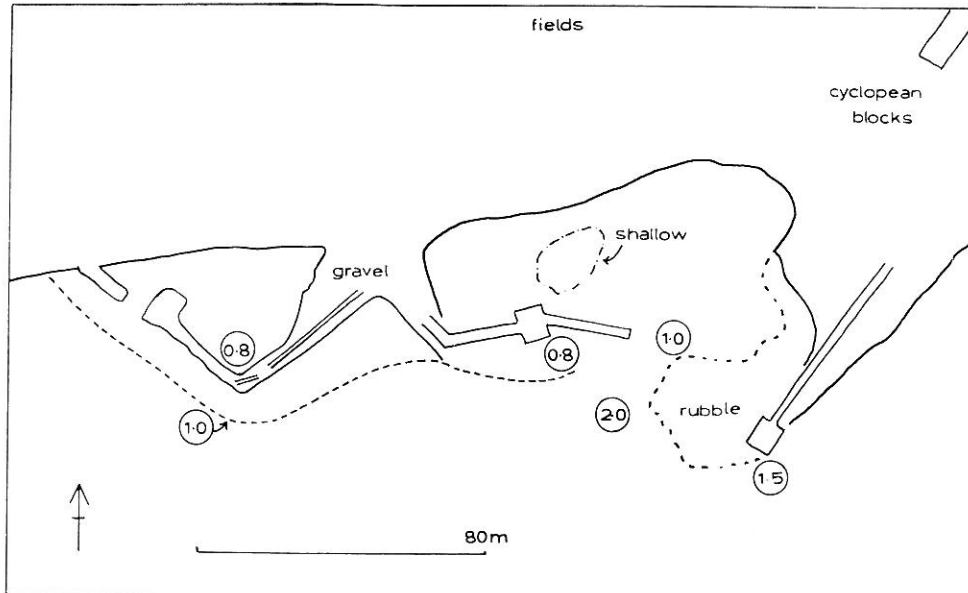

Figure 44. Old Cnidus.

NEW CNIDUS. Tekir. 36° 41' N., 27° 24' E. Chart 3924.

Strabo 14.2.15. Leake (1824, 226), Bean & Cook (1952). Figures 45, 46.

The site is at present being excavated by Prof. Iris Love. Specific details relevant to sea level change are the quay surfaces in the southern harbour at 1.0 and 1.7 m above sea level, the vertical mooring-bollard at some 2.0 m, and the stone mooring-rings with the centres of the mooring-holes at +1.0 m. All these indicate that there has been no submergence, and possibly even uplift of a few centimetres. A problem is presented by

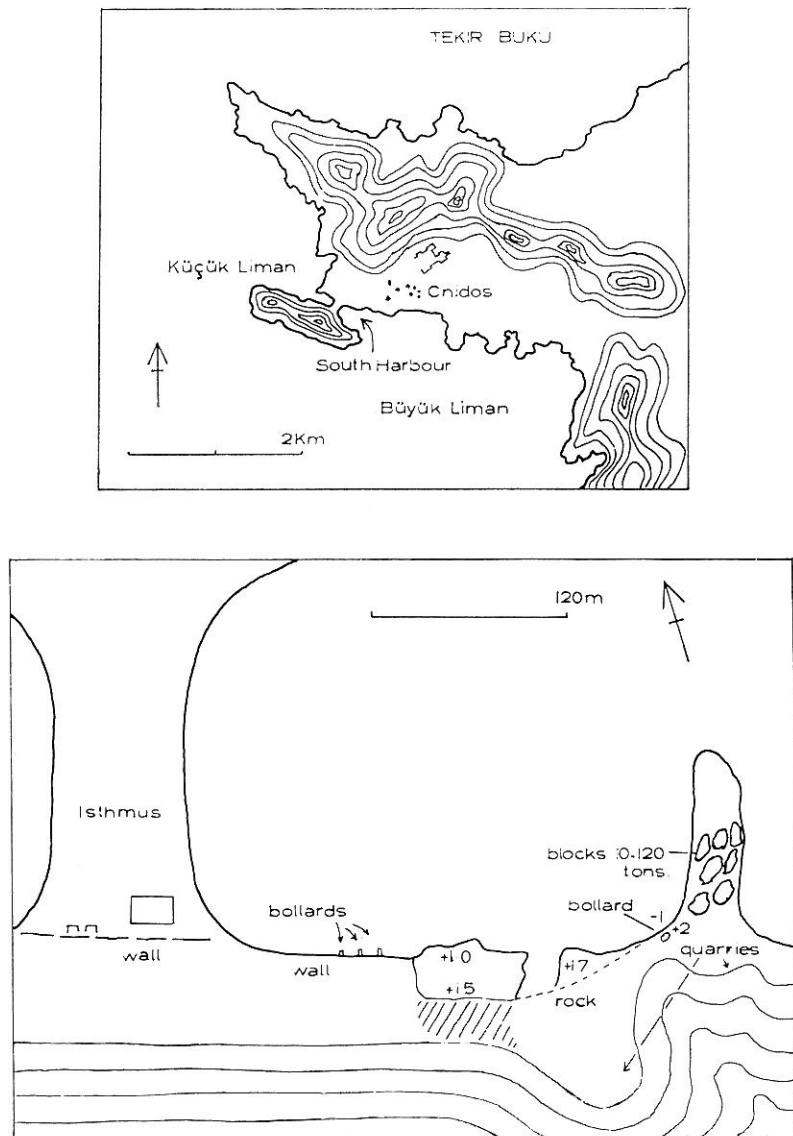

Figure 45. New Cnidus: General Plan. Detail: South Harbour.

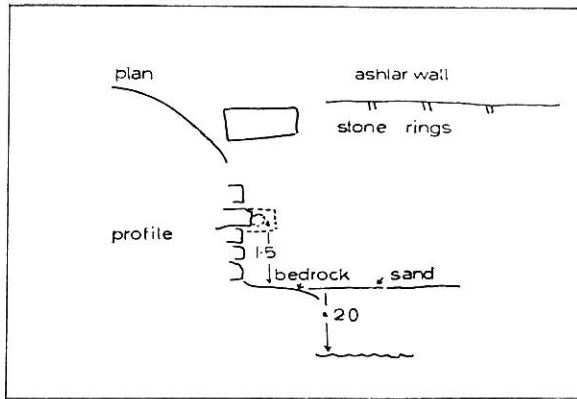
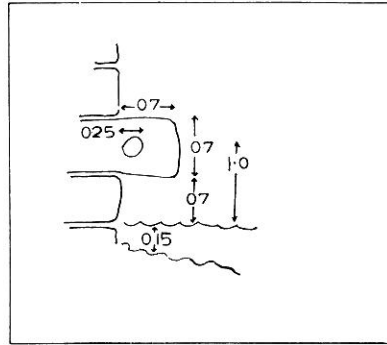

Figure 46. New Cnidus: Mooring-ring, S. Harbour. Mooring-ring, isthmus.

similar mooring-rings on the wall across the isthmus between the two harbours, which appear to be about 3.5 m above present sea level. A possible explanation is that there was a channel between the harbours, now covered by sand, and that this channel was flanked by quay surfaces at the back of which were the mooring-rings. There is no reason to suppose uplift of this part of the site, since the northern (trireme) harbour also seems to be adjusted to the present sea level.

ORHANIYE (modern name). $36^{\circ} 46' N.$, $28^{\circ} 10' E.$ Chart 1604. Figure 47.

Where the sand spit parts from the shore by the road there is an ashlar wall above the road, and on the spit itself a rectangular foundation of mortar and rough stones, and a wall about 25 m long. There is also a remnant of two apses, each about 2 m across. All these structures, though close to the water, indicate a negligible change of sea level, possibly 10 cm, since medieval times.

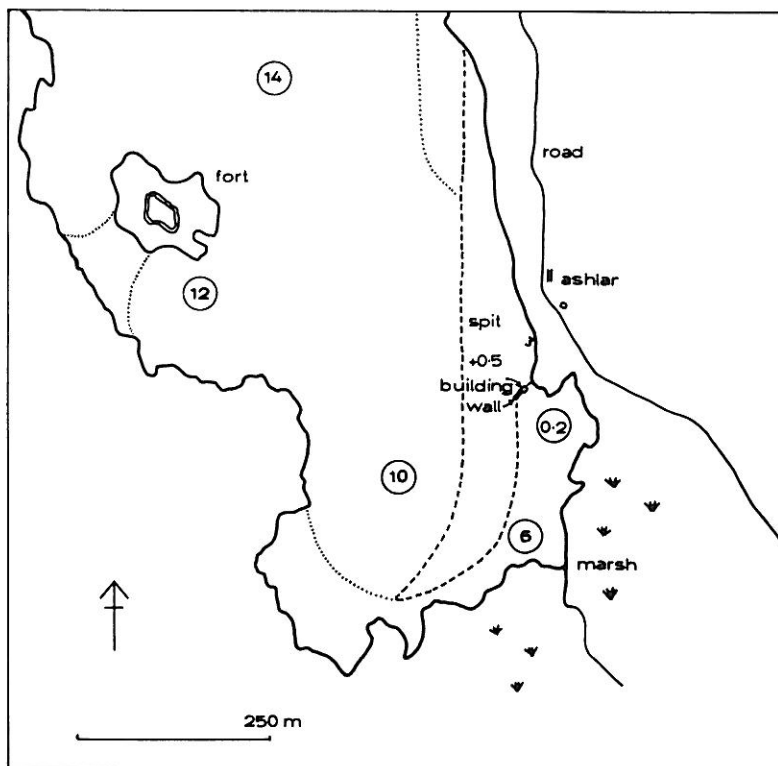

Figure 47. Orhaniye.

BOZBURUN (modern name). $36^{\circ} 42' N.$, $28^{\circ} 05' E.$ Chart 1604. Figure 48.

Ruins are marked on the chart, but none were investigated closely in the present survey. A trip by boat through the bay revealed that the most interesting area was that between the headland on the island marked B, the group of low sandy islands and the mainland shore opposite. The tip of the headland is prolonged by a row of massive irregular blocks, but whether these are natural, or compose a man-made breakwater is not known. There is a church on the larger island, though another island is little more than a sandbank, almost awash. There are walls on the shore and leading into the water, suggesting a change of 0.5–1.0 m.

SARANDA (modern name). $36^{\circ} 39' N.$, $28^{\circ} 07' E.$ Chart 1604. Figure 49.

Saranda is a group of three or four houses by a small jetty. To the east of the modern jetty is a broad rubble mole, now submerged. To the west are four small hooked jetties of rubble, also submerged. In all these cases the rubble may have collapsed, since the original structure may have been retained with a facing of blocks or wooden stakes. About $\frac{1}{2}$ km to the south-west is an anvil-shaped headland of very pronounced shape.

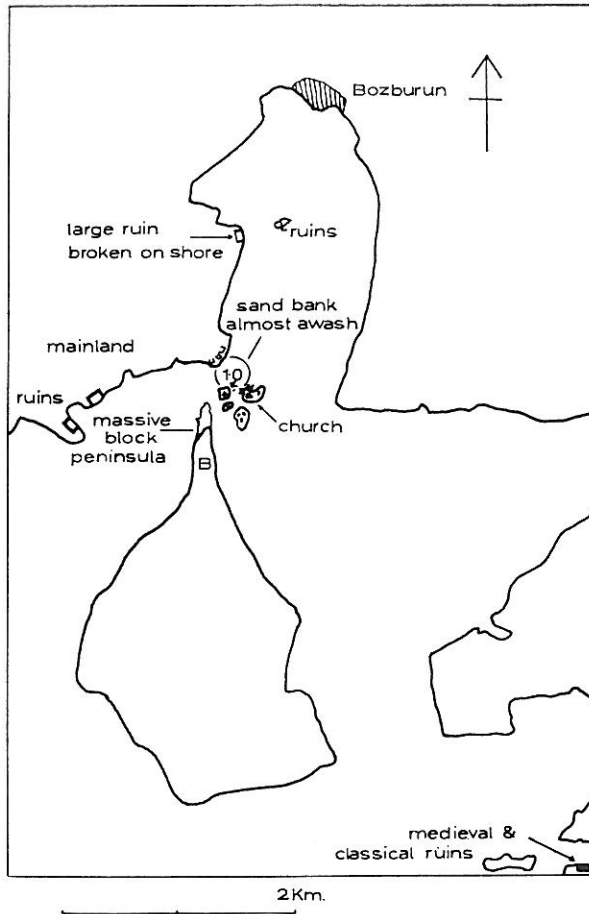

Figure 48. Bozburun.

On the hill behind the headland are rock cuttings and walls of yellow ashlar, almost completely concealed by earth and vegetation. On the headland itself is an olive-press and the foundations of a temple in ashlar, overlain by remnants of a Christian basilica. In the small sheltered bay to the north are two rubble jetties, the outer one submerged, the inner one breaking the surface by 50 cm. On the shore are medieval house-walls extending into a depth of 30 cm of water. From the assemblage of jetties and the house-walls it is probable that there has been a relative change of level of about 30–50 cm.

Extending beyond the jetties is an area of pottery and tiles, which, below the cliff at the tip of the headland, blends into a vast mound sloping at 45° into deeper water. Although some of the pieces may be roof-tiles from the basilica, many appear extremely large, while there are also large numbers of small dishes and bowls. The quantity suggests that they were thrown from the cliff deliberately.

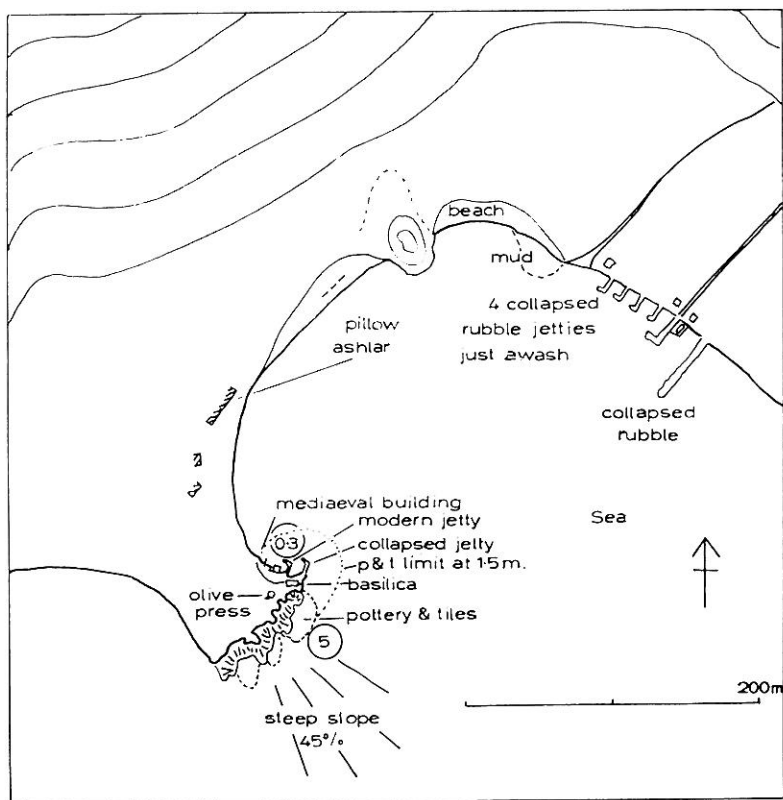

Figure 49. Saranda.

LORYMA. Oplotheke, Bozuk. 36° 35' N., 28° 03' E. Chart 1604.
 Strabo 14.2.14. Leake (1824, 223). Figure 50.

None of the earlier or Hellenistic remains are near the water level, but there is a row of stones on the beach between the northern temple foundations and the shore which may be part of a road. At the back of the bay is an apsidal building with a number of adjoining rooms, with the walls standing in 60 cm of water. Submergence is about 0.5–1.0 m.

PATARA. Gelemiç. 36° 16' N., 29° 19' E. Chart 236.
 Strabo 14.3.6. Stark (1956). Figure 51.

At several points on the shore of the lagoon there are large structures remaining to a height of 5–10 m, but they are difficult of access because of scrub, trees and reeds, as well as the waterlogged ground. The sandy beach completely closes the lagoon, which was once the harbour. In winter and spring the lagoon level rises and flows out to the west of the hill over the bar. The only building which might indicate a change of level is the arch on the east shore at the back of the lagoon, but the level of the lagoon itself may be higher than the sea, so this is not conclusive.

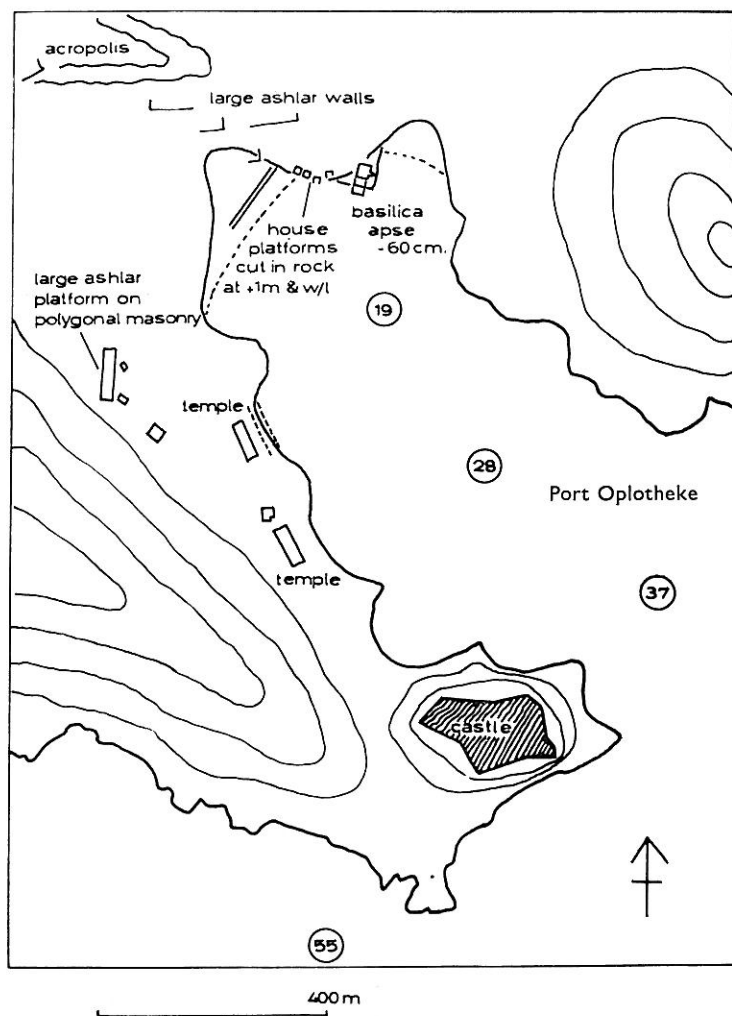

Figure 50. Loryma.

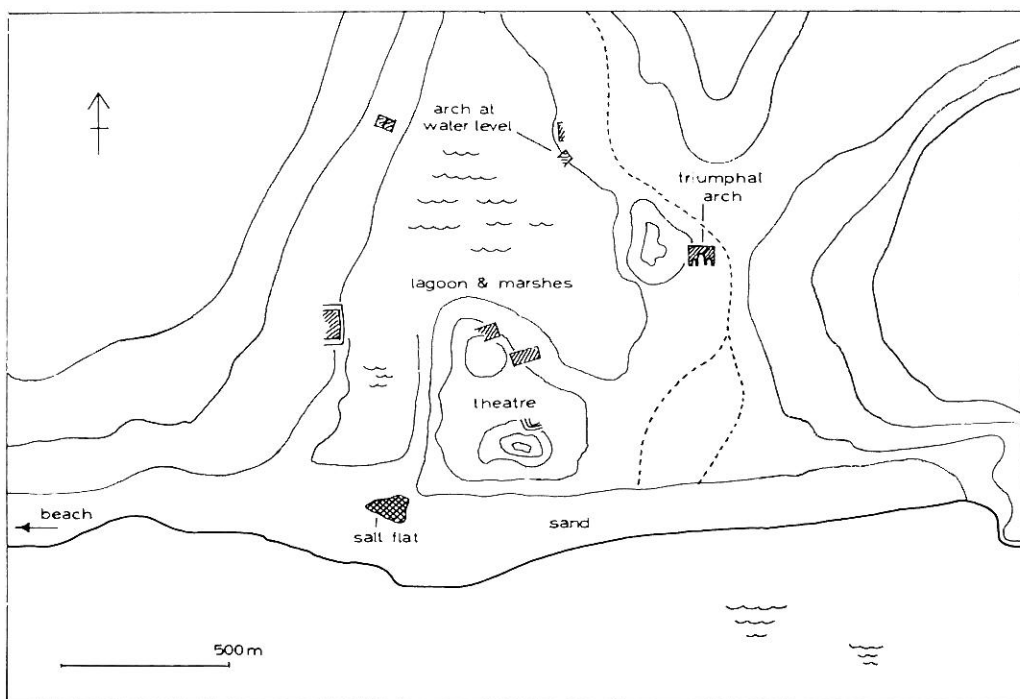

Figure 51. Patara.

ANTIPHELLUS. Kaş. $36^{\circ} 13' N.$, $29^{\circ} 38' E.$ Chart 2188.
Strabo 14.3.7. Leake (1824, 185). Figures 52, 53.

At A on the north side of the promontory there are quarries and tombs on the shore. A particularly fine tomb with a rectangular door and a triangular prismatic superstructure or monumental pedestal is cut from the solid rock and submerged by 2.0 m. The back of the roof of the tomb has been broken by waves.

At B there are rock cuttings and room foundations above the water line and medieval foundations just in the water. The breakwater C (Fig. 53) is cut in solid rock and is now largely submerged. There are a number of cisterns sunk into it, flooded to a maximum depth of 1.4 m (X & Y), and a rock-cut walkway, with its surface submerged by 1.3 m. Near the base of the breakwater beside some modern houses are the remains of crude walls, probably of medieval date, submerged by 18 cm.

In 1971 the nearby sites of Gemili Island and Kekova, the ancient Aperlae, were visited, and found to be submerged by 2.0 and 2.5 m. respectively.

ANDRIACE-MYRA. Kale. $36^{\circ} 13' N.$, $29^{\circ} 58' E.$ Chart 236.
Stark (1956). Figure 54.

Stark (1956, 156) states that Myra probably had a small port on the river at the back of the lagoon and a second at Andriace. The mouth of the lagoon is almost closed by a sand bar, and the narrow entrance is at the extreme eastern edge (Fig. 54). The water

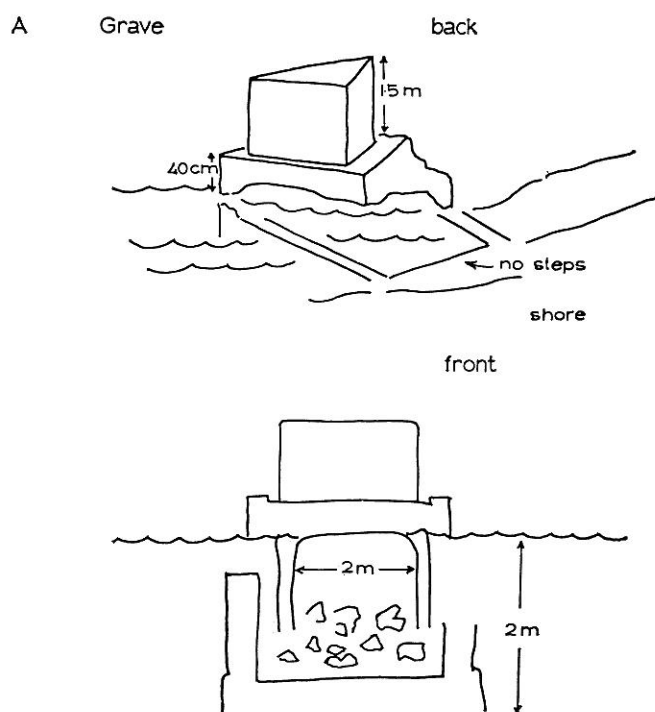
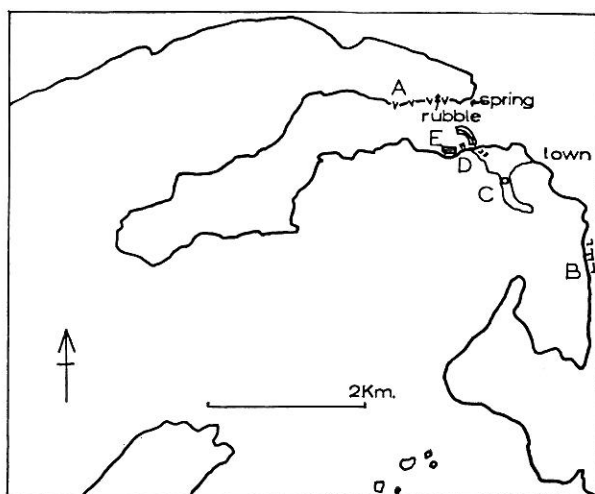
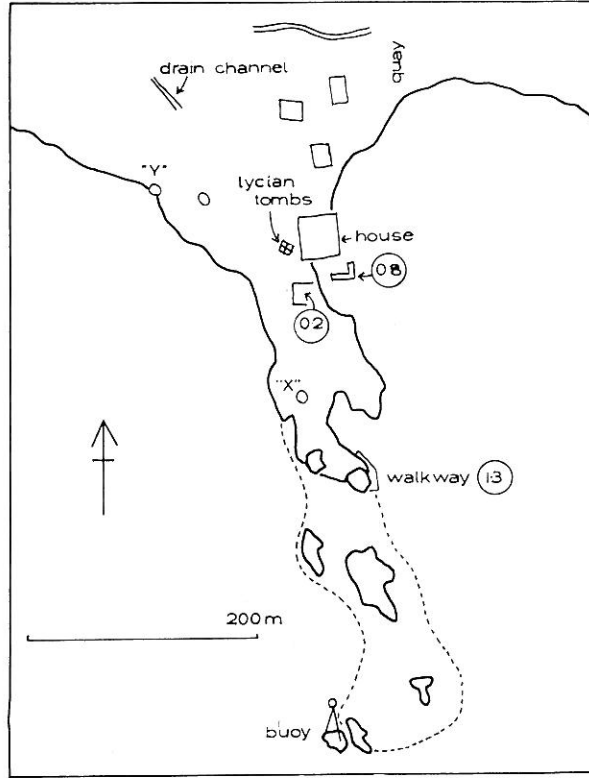

Figure 52. Kaş.

C



Silos



in metres

Figure 53. Ka.

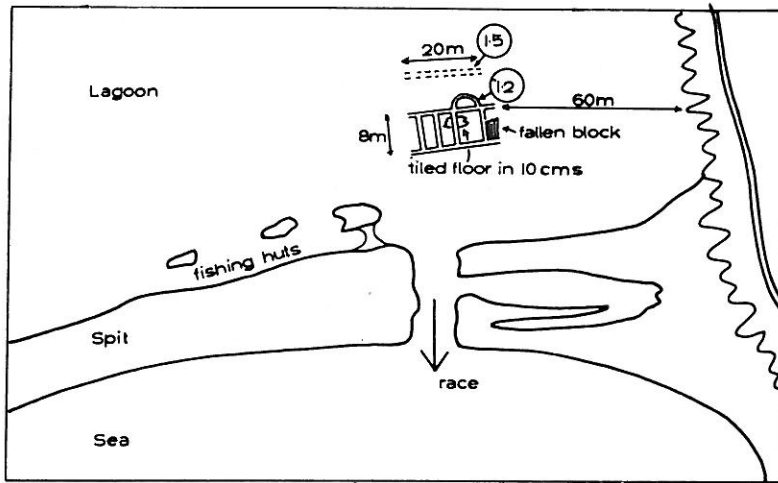

n.b. size of building is exaggerated

Fallen Block

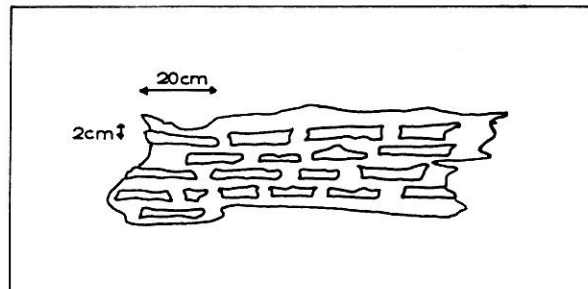

Figure 54. Kale.

flows out of the lagoon in a race and the lagoon level is about 5 cm higher than sea level. Just inside the lagoon entrance is an apsidal ruin with a number of rooms and a tiled floor submerged by 10 cm. Adjoining walls are submerged by 1.2 and 1.5 m, and there is a large fallen block of tile and mortarwork.

ANALYSIS AND DISCUSSION

Discussion of the mathematical, geological and geophysical reasoning behind the analysis of relative and absolute sea level changes is given elsewhere (Flemming, 1972), and a summary will be presented here. From the archaeological data at each site the best estimate of relative change of sea level is obtained, together with estimates of the probability that the change is more or less than the best estimate. In analysis of the Peloponnesian data only the best estimates of change were used, but in the analysis of the Turkish data the probability estimates were used.

In the general case the observed relative change of sea level at each site is made up of the algebraic sum of the world-wide eustatic sea level change since the site was occupied, and the vertical earth movement at the site over the same time. The first factor must be the same for all sites of the same age, but will vary for different periods of occupation of the same site. The second factor will in general be different for every site and will also vary with the age for a single site. Certain simplifying assumptions can be made. Although earth movements occur with varying magnitudes and frequencies at different sites, it is reasonable to assume that the direction and rate of movement at each site has been more or less constant throughout the last 5,000 years. Statistical tests on the Peloponnesian data (Flemming, 1968 *a* & *b*) showed that there was very poor correlation between age and displacement of sites, indicating that an explanation purely in terms of a steadily changing sea level could not account for the variability observed. On the other hand, an equation was fitted which contoured the area in terms of the rate of displacement, and this produced a much better fit (Fig. 55). This implies a variable earth movement from region to region, accounted for in terms of geological structure and gravity anomalies. The study of the Peloponnese did not reveal any consistent eustatic sea level change in the last 2,000 years to within an accuracy of ± 50 cm.

More detailed analysis was made of the Turkish data. Probability estimates were made of relative change at each site, and these were used as input to the surface fitting programme as if each estimate were a separate observation. In addition, an attempt was made to separate the eustatic and geological factors by purely statistical means. It was proposed that the relative change of level at each site should be best expressed as follows:

$$Z = f(T) + g(x, y)T$$

where

$$\begin{aligned} Z &= \text{the relative displacement,} \\ f(T) &= \text{a third-degree function of time,} \\ g(x, y) &= \text{rate of local displacement expressed as a fourth-degree function of} \\ &\quad \text{arbitrary geographical co-ordinates, } x, y. \end{aligned}$$

This expression was expanded, and the values of Z , x , y , and T inserted for each site, and a multiple regression applied to find the best coefficients for the equation. The terms were then separated into those involving x and y only, representing the geological regional factor, and those involving T only, representing the eustatic factor independent of location. The two equations are plotted in Figures 56 and 57.

It will be seen that the deduced eustatic sea level variation is of the order of 30 cm and that sea level 2,000 years ago was very close to present sea level. This is supported by Mörner (1969). The distribution of earth movement shows a folding along the general line of the coast, with anticlinal folds extending westwards over the Çeşme Peninsula and west of south over the Cnidus Peninsula towards Rhodes.

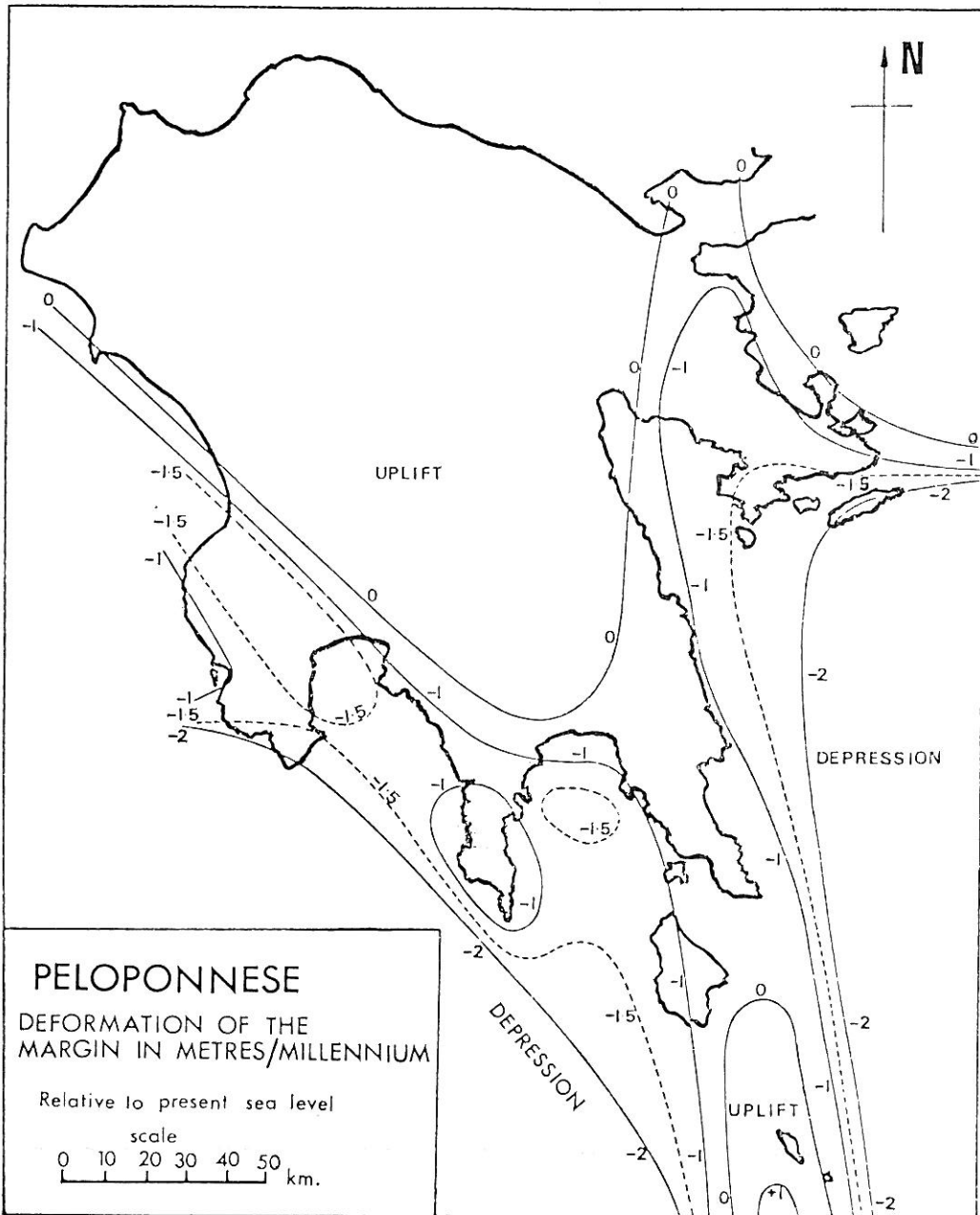

Figure 55. Plot of the relative rate of deformation of the margin of the Peloponnese in metres per millennium. The contour interval is at 1 m/millennium, with the 1.5 m/millennium line added to show the detailed structure in the Gulf of Messenia and the Gulf of Lakonia.

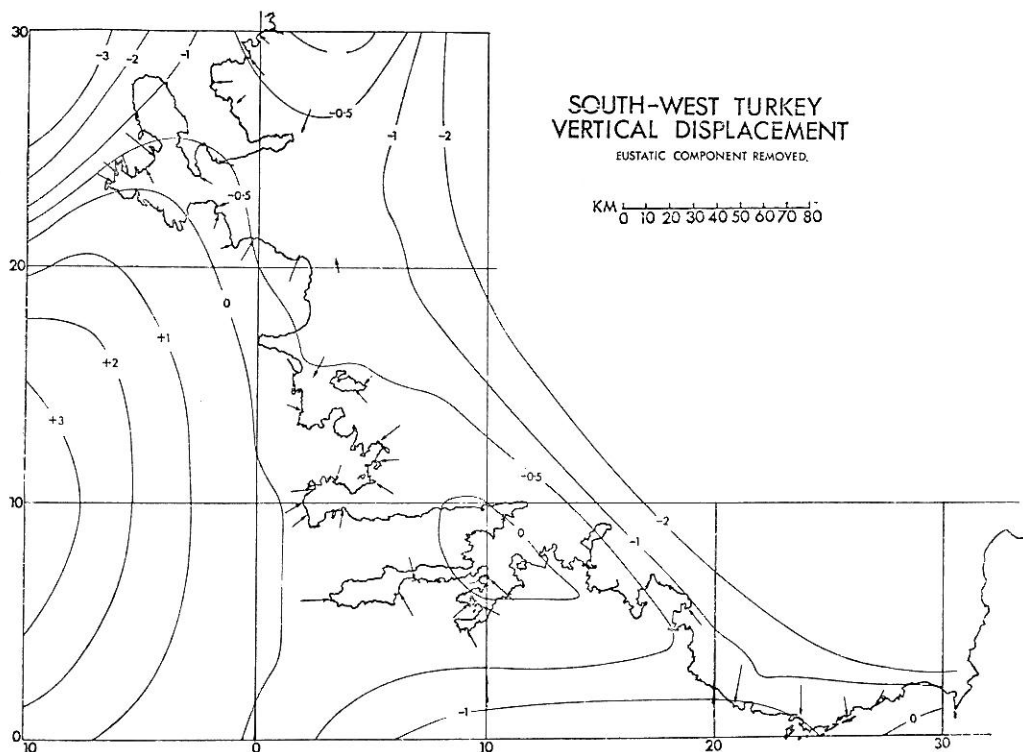

Figure 56. Plot of the relative rate of displacement of the margin of South-West Turkey after removal of the eustatic component. Contour interval is 1 m/millennium, with the 0.5 m/millennium line added to show detailed structure near the coast. In this presentation the contours in the open Aegean suggest uplift, but this is a mathematical fiction generated by the computer programme as there are no field data from this region. Nevertheless, the trend of the contours indicates the possible form which, with the sign reversed, might be taken by a depression.

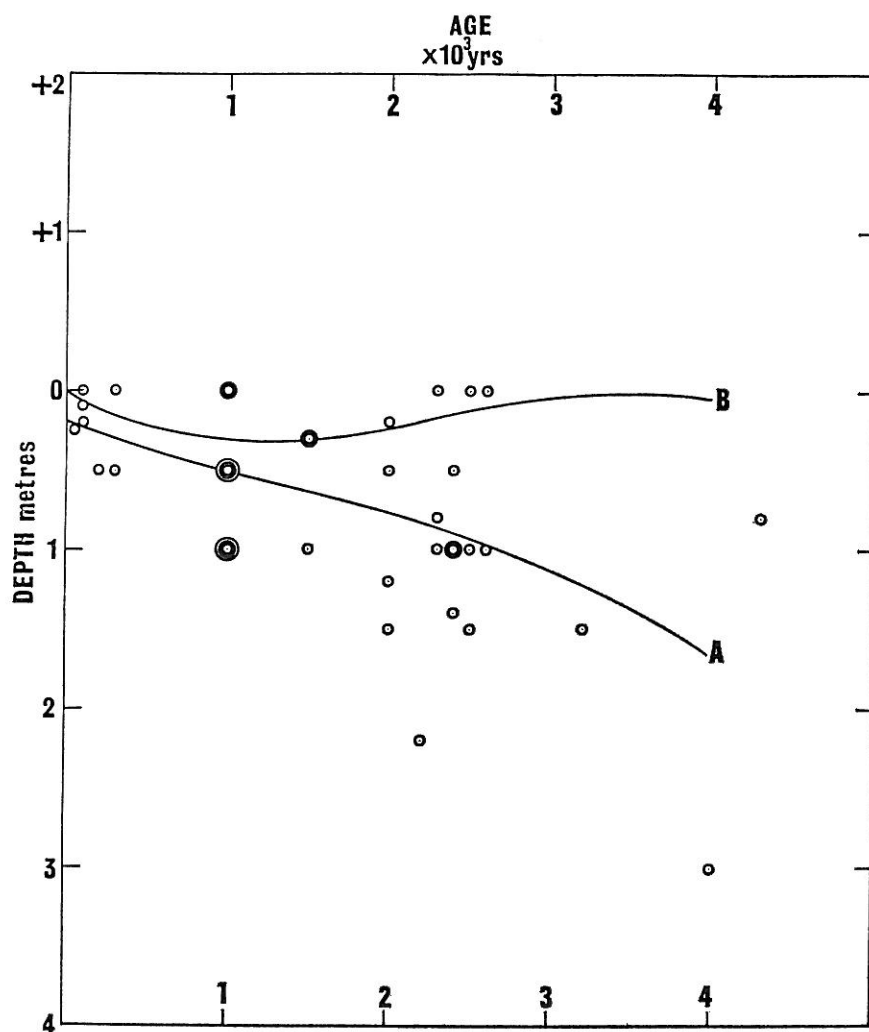

Figure 57. Plot of displacement of sites in S.W. Turkey against age of site in thousands of years. The heavy dots indicate double and triple points. Curve A is the mean displacement of sites of the same age, ignoring the possibility of earth movements. This shows that, as would be expected, older sites are deeper, but this could be due to eustatic or tectonic factors. Curve B shows the eustatic sea level curve obtained after separation of the tectonic factor shown in Figure 56.

CONCLUSIONS

Archaeological sites provide a highly sensitive method for deducing relative sea level changes. In the Aegean the close spacing of sites is such that statistical treatment enables separation of eustatic and tectonic factors over the last 3,000 years. To within the order of accuracy of the method, that is 20 cm and 200 years, the eustatic sea level change has not exceeded 30 cm in the last 3,000 years. There have certainly been deviations from this curve with durations of a few hundred years, but it is unlikely that the total amplitude of sea level change ever exceeded ± 1 m relative to the present sea level in the last 3,000 years.

If one takes the plots of earth movement from the Peloponnese and Turkey together, it is apparent that there is a general down-warping towards the centre of the Aegean basin, with a pronounced anticlinal fold extending east of south from Greece to Crete, and west of south from Turkey towards Crete. This suggests that the Cretan island arc is currently being folded and that the folding extends to the continental blocks at each extremity. The plans put forward in this paper are compatible with the distribution of historical seismicity discovered by Ambraseys (1965, 1970) and broadly compatible with the locations of tectonic plate boundaries put forward by McKenzie (1970).

The proposed eustatic sea level curve is at least compatible with data from other areas, but should not be taken as firmly established. Nevertheless, the fact that the curve is reasonable is a partial vindication of the statistical methods used. This underscores the fact that, in a site less than 3,000 years old, any observed sea level change is more likely to be due to local earth movement than a world-wide eustatic change. If the relative change at a site is more than 30–50 cm, there is certainly a contributory factor of earth movement, but every archaeological site should be treated as a special case, and it is not possible to argue for an 'expected' relative sea level change on the basis of the age of a site, nor is it possible to derive dates of structures from their depth of submergence on the basis of an expected sea level time curve. At all sites totally independent estimates of sea level change must be made.

REFERENCES

- Ambraseys, N. N. 1965 A note on the Seismicity of the Eastern Mediterranean. *Studia geophys. geod.* **9**, 405–10.
- Ambraseys, N. N. 1970 Some characteristic Features of the Anatolian Fault Zone. *Tectonophysics.* **9**, 143–66.
- Bammer, A. 1965 Zum jüngeren Artemision von Ephesos. Die Terrasse des jüngeren Artemisions und eustatische Schwankungen des Meeresspiegels. *Jahreshefte des österreichischen archäologischen Instituts*, **47**, 1964–65, 126–45.
- Bartoccini, R. & Zanelli, A. 1958 *Il Porto romano di Leptis Magna* [Bollettino del Centro di Studi per la Storia dell'Architettura, 13, Suppl.], 222 pp. Rome.
- Bean, G. E. 1966 *Aegean Turkey: an archaeological guide*, 288 pp. London.
- Bean, G. E. & Cook, J. M. 1952 The Cnidia. *BSA*, **47**, 171–212.
- Bean, G. E. & Cook, J. M. 1955 The Halicarnassus Peninsula. *BSA*, **50**, 85–171.
- Bean, G. E. & Cook, J. M. 1957 The Carian Coast. *BSA*, **52**, 58–146.
- Béquignon, Y. & Laumonier, A. 1925 Fouilles de Teos (1924). *Bulletin de Correspondance Hellénique*, **49**, 281–321.
- Cook, J. M. 1954 The Topography of Klazomenai. *Archaiologike Ephemeris*, 1953–54 [Studies in Memory of G. P. Oikonomos], vol. 2, 149–57.

- Cook, J. M. 1959 Old Smyrna. *BSA*, 53-54, 1958-59, 1-35.
- Demangel, R. & Laumonier, A. 1923 Fouilles de Notion (1921). *Bulletin de Correspondance Hellénique*, 47, 353-86.
- Ervin, M. 1967 News-letter from Greece. *AJA*, 71, 293-306.
- Flemming, N. C. 1968a Holocene Earth Movements and Eustatic Sea Level Change in the Peloponnese. *Nature, Lond.* 217, 1031-2.
- Flemming, N. C. 1968b Archaeological evidence for sea level changes in the Mediterranean. *Underwater Association Report 1968*, 9-12.
- Flemming, N. C. 1969 Archaeological evidence for Eustatic Change of Sea Level and Earth Movements in the Western Mediterranean in the last 2,000 years. *Spec. Pap. geol. Soc. Am.* 109, 125 pp.
- Flemming, N. C. 1972 Eustatic and Tectonic factors in Relative Vertical Displacement of the Aegean Coast, in Stanley, D. J. (ed.) *Sedimentation of the Mediterranean*. Smithsonian Institution.
- Fowler, H. N. & Stillwell, R. 1932 *Corinth, I.1. Introduction, Topography, Architecture*, 239 pp. Cambridge, Mass.
- Frödin, O. & Persson, A. W. 1938 *Asine: Results of the Swedish Excavations, 1922-1930*, 452 pp. Stockholm.
- Giannakopoulos, P. E. 1966 *Gytheion*, 204 pp. Athens.
- Grundy, G. B. 1896 An investigation of the topography of the region of Sphacteria and Pylos. *JHS*, 16, 1-54.
- Hall, J. E. 1969 Ancient Underwater City. *Oceans*, 1 No. 4, 48-51.
- Harding, A., Cadogan, G. & Howell, R. 1969 Pavlopetri, an Underwater Bronze Age Town in Laconia. *BSA*, 64, 113-42.
- Hawthorne, J. G. 1965 Kenchreai, Port of Corinth. *Archaeology*, 18, 191-200.
- Higgins, C. G. 1966 Possible disappearance of Mycenaean coastal settlements of the Messenian Peninsula. *AJA*, 70, 23-9.
- Hogarth, D. G. 1908 *Excavations at Ephesus. The Archaic Artemisia . . .*, 344 pp. London.
- Hope Simpson, R. 1965 *A Gazetteer and Atlas of Mycenaean Sites* [Bulletin, Institute of Classical Studies, Supplement 16], 200 pp. and 6 maps. London.
- Hope Simpson, R. 1966 The Seven Cities offered by Agamemnon to Achilles. *BSA*, 61, 113-31.
- Jameson, M. H. 1969 Excavations at Porto Cheli and Vicinity, Preliminary Report, I: Halieis, 1962-1968. *Hesperia*, 38, 311-42.
- Kleiner, G. 1966 *Alt Milet* [SB Frankfurt/M, Vol. 4, No. 1], 26 pp. Wiesbaden.
- Leake, W. M. 1824 *Journal of a Tour in Asia Minor*, 362 pp. London.
- McKenzie, D. 1970 Plate Tectonics of the Mediterranean Region. *Nature, Lond.* 226, 239-43.
- Mörner, N. A. 1969 Eustatic and Climatic changes during the last 15,000 years. *Geologie Mijnb.* 48, 389-99.
- Negris, P. 1904 Vestiges Antiques Submergés. *Athenische Mitteilungen*, 29, 340-63.
- Newton, C. T. 1863 *A History of Discoveries at Halicarnassus, Cnidus, and Branchidae*, Vol. 2, 835 pp. London.
- Roebuck, C. 1959 *Ionian Trade and Colonization* [Monographs on Archaeology and Fine Arts, sponsored by the Archaeological Institute of America and the College Art Association of America, 9], 148 pp. New York.
- Schäfer, J. & Schläger, H. 1962 Zur Seeseite von Kyme in der Aeolis. *Archäologischer Anzeiger*, 1962. 1, 40-57.
- Schuchhardt, C. 1912 in Conze, A. (ed.) *Altertümer von Pergamon*, Vol. I.1, 61-143.
- Scranton, R. L. & Ramage, E. S. 1964 Investigations at Kenchreai, 1963. *Hesperia*, 33, 134-45.
- Stark, F. 1956 *The Lycian Shore*, 204 pp. London.
- von Gerkan, A. 1935 in Wiegand, T. (ed.) *Milet*, Vol. II.3, 135 pp. Berlin.
- Waterhouse, H. & Hope Simpson, R. 1961 Prehistoric Laconia, Part II. *BSA*, 56, 114-75.
- Weber, G. 1901 Erythrae. *Athenische Mitteilungen*, 26, 103-18 & Pl. VII.

Discussion

Blackman I have been over much of the same ground as Dr. Flemming, also looking for evidence of sea level changes. My conclusions, with respect to the individual sites, are very close to his.

Peel Your application of fairly straightforward statistical techniques is most interesting. Could you describe them in more detail?

Flemming The analysis used on the Peloponnesian data was a conventional surface fitting programme. The technique used for Turkey was an advance on this. First, instead of making a single estimate of the relative change of level at a site, probability weights were allocated to the most probable estimate and to less likely estimates on either side. Ten points were allotted for each site, of which, for example, seven might go for the best estimate, two for an estimate 25 cm more than the best, and one for an estimate 25 cm less than the best. In subsequent analysis each point was treated as a single observation.

The study of the Peloponnesian had suggested that tectonic regional variations could reasonably be fitted in terms of third- or fourth-degree polynomials, while a eustatic sea level curve would have to have one or two turning points in it, and thus would most probably be a third-degree curve. As explained in the paper, it was proposed that the net relative displacement at a site was the algebraic sum of two such polynomials. There is, however, a snag. The stepwise regression analysis performed by the computer minimises the residual errors between the observed data and the sum of the two polynomials which are generated. Mathematically the computer may adjust the two polynomials so that their sum satisfies the criterion for minimum error, but individually, when taken as having physical significance in the field, the equations may be absurd. The answer which gives the best mathematical fit is also probably the correct physical solution, but it is not logically necessary that it be so. One has to check to see if the physical meaning of the solution is absurd or not. If not, then it is probably good.

Hague It seems odd to have to ask "Does it look sensible?". Surely your sort of study ought to give answers in precise terms.

Flemming Mathematics gives a precise answer if all the initial data are known, and if logical procedures are followed. The trouble in the earth sciences is that one is always losing data through erosion and decay and geological change. Many of the facts which are needed to reconstruct the past have been destroyed. From a mathematical point of view one is then faced with trying to solve n equations with $n + 1$ unknown factors, which strictly speaking is impossible. However, by making assumptions about the type of equations which may occur in the solution, and so on, one can reduce the uncertainty and get a solution which is mathematically precise. However, the computer does not know what is geologically possible or reasonable, and if some of your assumptions have implications which are geologically unsound, then the final answer may be totally wrong. There are unlikely to be two possible mathematical solutions close together, and thus the answer from the computer will either be good or absurd. It is unlikely

to be just vaguely wrong. Thus the test of absurdity is a reasonable way of arriving at a very reliable answer.

Hague Can you not get this by drawing by eye?

Flemming I could not have drawn the contours by eye, nor could I have separated the tectonic and sea level/time curve. There are four variables—geographical coordinates (x and y), sea level, and time—and we have nearly 300 sets of observations. The human mind is simply not capable of drawing contours through 300 points in four dimensions.

Davidson We have found some quarries on the coast of North Africa which had been cut down to sea level, with a rock-cut wall left as protection from the sea and drainage channels through the wall to keep the workings dry. What was the probable height of these workings above sea level?

Flemming I have assumed that it was easier to quarry downwards than to knock the wall further back into the cliff. They would have quarried as close as possible to sea level, say to 10 cm above sea level in a fairly sheltered place.

Blackman At Koyunbaba in Western Turkey, just north of Myndus, there are quarries where the sea now just laps on to the shelf at the water's edge (Bean & Cook, 1955, 130). Sea level must have changed slightly since these were worked.

Flemming At Apollonia one can show that the original sea level must have been at a certain level to allow boats into the harbour, and this leaves the quarries absolutely at water level.

Blackman In many cases one can work out minimum and maximum change in sea level at a particular site, using indices like the depth of water in rock-cut channels and the relationship of features like quarries to present sea level. The main problem is to date the features. I hope to discuss this in a later paper (pp. 115–38).

Wallace A somewhat different pattern of quarrying has been practised on the South Coast of England, where there are tides and rougher seas to contend with. It might be termed tidal quarrying, in that at high tide boats are taken right to the working face, which is worked down to low tide level. The stone is loaded directly into the boats, which are by then aground on the quarry floor, which is left flat and clear of obstructions. The boats are then floated off again on the rising tide. But to give shelter and prevent bumping on the bottom during the awkward period when they were only partially afloat, it was a common practice to leave deliberate breakwaters of unquarried natural rock. There is one large and several smaller examples of such semi-natural breakwaters in the Bembridge stone at Whitecliff Bay in the Isle of Wight, where such tidal quarrying was practised down to the last war, and there are also examples on the Dorset coast.

Flemming Exposure comes into this a lot. As Throckmorton said, one needs to have a basic knowledge of seamanship. Everything depends on the exposure of the site, and the dominant direction of the wind and waves. A quay or harbour wall in an exposed position must have been a metre or more above the water, whereas at Marzamemi in southern Sicily the modern fishing quay slopes right down to the water.

Green How did you calculate a depth datum for this work? Presumably secondary ports may be some way from your sites. Did you level from these to the submerged sites?

Flemming The datum used was the sea surface itself. We just measured the change of the site relative to the sea.

Green Did you take tidal changes into account? What was the maximum tide range?

Flemming About 10 cm; but you can get a rise in sea level of up to a metre with strong onshore winds. I have to admit that while looking for marks on the shore of these sites I only visited them for a day or so and I have no measurement of the tide. I cannot be more accurate than 10 cm. At Elaphonisos they measured the tide and checked it every hour for the first two days and then every day and then once a week. The tidal change was negligible.

Green We found the same thing at Cape Andreas: a close correlation with tidal predictions from secondary ports. But this did vary with the wind.

Flemming Ten years ago we thought it very clever to be able to measure relative sea level change to an accuracy of ± 1 m. In that context the tidal range in the Mediterranean was not important. Now, however, we are able to observe to about 25 cm on average, and 10 cm in a few cases, so that the tide, even in the Mediterranean, is a limiting factor.

Prof. Charnock

Reprinted from Vol. XXIII of the Colston Papers, being the Proceedings of the Twentythird Symposium of the Colston Research Society held in the University of Bristol, April 4th to April 8th, 1971. Published by Butterworths Scientific Publications, London.

Printed in Great Britain